

SPT

Gauge or absolute pressure transmitters

825B135B

Features

Gauge pressure:	from 0,6KPa (6mbar) to 40MPa (400bar)
Absolute pressure:	from 2KPa (20mbar) to 3MPa (30bar)
Power supply:	12÷42Vdc
Max. measurement accuracy:	±0,075%
Analog output resolution:	16 bit
Communication Protocol:	HART
Calibration and Configuration:	with onboard buttons
Data display:	backlit alphanumeric display
Data Storage:	su EEPROM
Housing Mechanical protection:	IP67



Warranty

Products supplied by SGM LEKTRA are guaranteed for a period of 12 (twelve) months from delivery date according to the conditions specified in our sale conditions document.

SGM LEKTRA can choose to repair or replace the Product.

If the Product is repaired it will maintain the original term of guarantee, whereas if the Product is replaced it will have 12 (twelve) months of guarantee.

The warranty will be null if the Client modifies, repair or uses the Products for other purposes than the normal conditions foreseen by instructions or Contract.

In no circumstances shall SGM LEKTRA be liable for direct, indirect or consequential or other loss or damage whether caused by negligence on the part of the company or its employees or otherwise howsoever arising out of defective goods

Factory Test Certificate

In conformity to the company and check procedures I certify that the equipment:

SPT..... Production and check date:

Serial n.

is conform to the technical requirements on Technical Data and it is made in conformity to the SGM-LEKTRA procedure

Quality Control Manager



Process Control and Measurement

SPT - Operation

- Compact digital system, 12÷45Vdc 2-wire technology, suitable for liquid, gas and steam applications.
- Configuration and calibration via onboard display or via HART software
- Ranges from 0,6 KPa to 40MPa
- Accuracy: $\pm 0.075\%$

Thanks to the automatic measure compensation, according to the operating temperature variation, the **SPT** pressure transmitters series has the feature to maintain this its stability and its accuracy constant over time. The **SPT** series industrial sectors application are several: steel industry, pharmaceutical, food and other.

The process pressure is transmitted, through the isolating diaphragm and the oil fill, to the sensitive silicon chip placed in the sensor center. In the same way the reference pressure is transmitted to the opposite side of the sensing diaphragm. Il diaframma sensibile viene quindi flesso in modo proporzionale alle pressioni applicate. The sensitive diaphragm bending originates a resistivity variation of the silicon chip that produces a reference voltage variation. The voltage difference generated by the sensor is converted into a two-wire 4÷20mA analog signal and, by means of a modulation, the standard **HART** bidirectional communication is possible.

1. Operating Principles

1.1 - Pressure sensor

The **SPT** sensor module key element is shown in Fig.1-2.

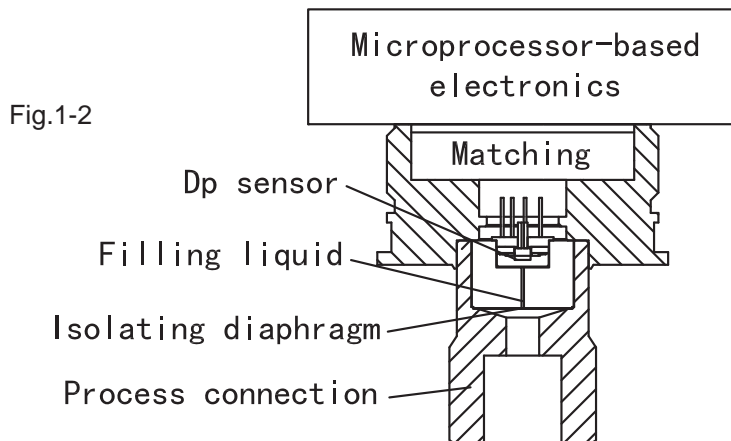

The differential pressure transmitter includes two functional units: the main unit and the auxiliary unit.

The main unit includes the process connection and the sensor. The chip side opposite to the pressure to be measured, is connected to atmospheric pressure (gauge pressure measurement) or to the vacuum cell (absolute pressure). The applied pressure on the measuring diaphragm, transmitted to the silicon chip through the filling liquid, changes the chip electrical resistance with consequent variation of the pressure detection system output voltage. This voltage variation is then translated into a 4-20mA current output variation.

1.2 - Temperature Compensation

The **SPT** is able to compensate the possible measurement deviations caused by temperature variations.

The temperature detection circuit, located inside the A/D converter, sends to the microprocessor the information necessary to process the measured value adjustment of the differential pressure in relation to the temperature change (ΔT).

1.3 - A/D converter

A/C converter converts the analog signal to digital signal, which is then input into the microprocessor.

The resolution is 16 bit

1.4 - Microprocessor

The microprocessor performs the following operations:

- controls the A/D and D/A conversion;
- provides self-diagnosis;
- performs digital communication;
- manages the linearization, range and system integration data.

1.5 - Memory

The system configuration parameters are stored in EEPROM, so that the stored data is not lost in case of supply voltage interruption.

1.6 - D/A converter

The D / A converter transduces the digital signal from the microprocessor, into a 4÷20mA analog output signal.

1.7 - Digital Communication

The **SPT** transmitters are tested and calibrated using a portable or fixed programmer, supported by the **HART** Communication Protocol.

The **HART** protocol applies the industry standard.

The digital signal (1200÷2200Hz) overlapped on 4÷20 analog signal will not affect 4÷20 mA process signal.

2. Technical data

2.1 - Applications

The **SPT** series is applicable in pressure measurements of liquids, gases and vapors.

2.2 - Operation range

The operation ranges are in used cell function in the **SPT** series specific model, as reported in the following table:

Range Code	Measurement range	Range limits	Accuracy ±0.075% (cod. H)
B	0÷ 0,60...6KPa (0÷60...600mmH ₂ O) (0÷6...60mbar) gauge p.	-6 ÷ +6 kPa	D
C	0÷ 2...40KPa (0÷20...4000mmH ₂ O) (0÷20...400mbar) gauge p.	-40 ÷ +40 kPa	D
D	0÷ 2,5...250KPa (0÷0.25...25mH ₂ O) (0÷25...2500mbar) gauge p.	-100 ÷ +250 kPa	D
F	0÷ 30KPa...3MPa (0÷3...300mH ₂ O) (0÷0,3...30bar) gauge p.	-100 ÷ +3000 kPa	D
G	0÷ 0,1...10MPa (0÷10...1000mH ₂ O) (0÷1...100bar) gauge p.	-0.1 ÷ +10 MPa	D
H	0÷ 0,21...21MPa (0÷21...2100mH ₂ O) (0÷2,1...210bar) gauge p.	-0.1 ÷ +21 MPa	D
I	0÷ 0,4...40MPa (0÷40...4000mH ₂ O) (0÷4...400bar) gauge p.	-0.1 ÷ +40 MPa	D
L	0÷ 2...40KPa (0÷200...4000mmH ₂ O) (0÷20...400mbar) p. relativa	0 ÷ +40 kPa	D
M	0÷ 2,5...250KPa (0÷0.25...25mH ₂ O) (0÷25...2500mbar) absolute p.	0 ÷ +250 kPa	D
O	0÷ 30KPa...3MPa (0÷3...300mH ₂ O) (0÷0.3...30bar) absolute p.	0 ÷ +3000 kPa	D

Note: **D**, available; **N**, unavailable.

Tab.2-1

2.3 - Output Signal

4-20mA analog signal with two-wire connection and digital communication with HART protocol.

2.4 - Power supply

Standard 24Vdc, 12-45Vdc taking account of the load applied to the output signal, as shown in Fig. 2-1

2.5 - Output signal load

The maximum applicable load value to the output signal is a function of the supply voltage applied, as shown in fig 2-1. The maximum applicable load value is provided by the following mathematical formula:

$$R_L = (V_s - 12V_{dc}) / 23mA ; R_L, \text{ maximum load; } V_s, \text{ supply voltage applied.}$$

Fig.2-1

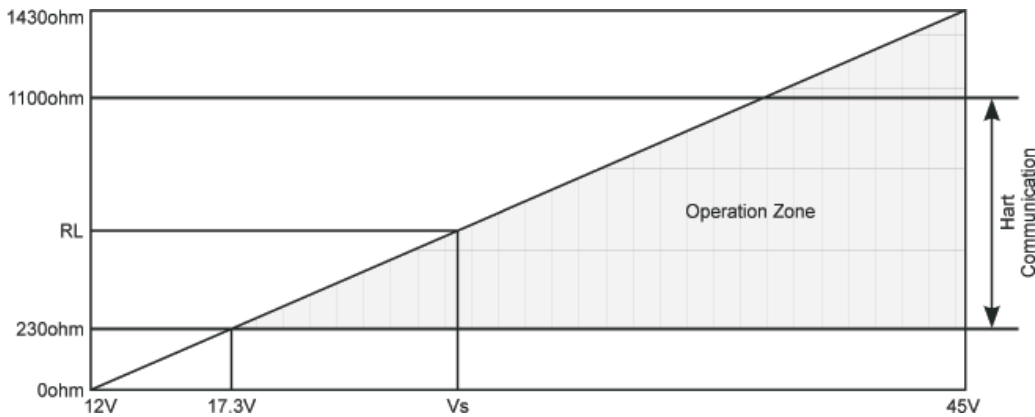

2.6 - Display

Field display for current output, 0-100%, engineering units with LCD backlit display

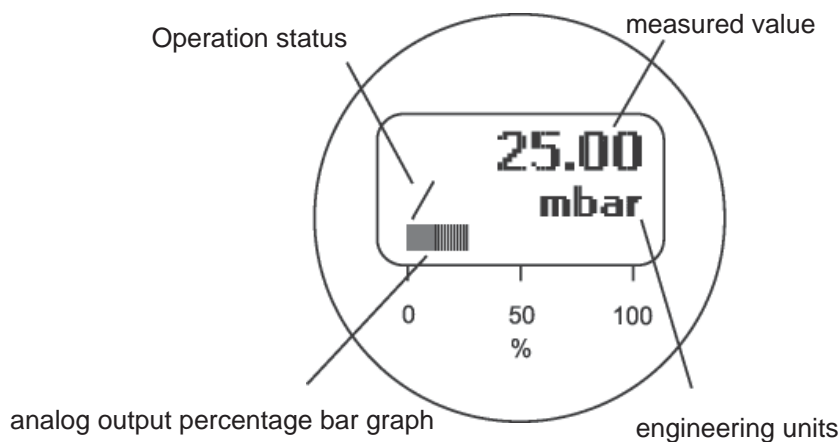

2.7 - Zero and Span calibration

The zero and span calibration can be performed using the on-board buttons, or via HART communication.

2.8 - Positive and negative OFFSET

- Differential pressure transmitter:
The max. positive OFFSET is the difference between the upper value limit and the measure range > URL (upper range limit)
- Gauge pressure transmitter:
The max. positive OFFSET is the difference between the URL and the measure range. The max. negative OFFSET is > than 1 Atm
- Absolute pressure transmitter:
The max. OFFSET is the difference between the URL and the measured range. The negative OFFSET does not exist.

2.9 - Alarms

A self-diagnostic program detects a problem when the output signal is higher than 20,8 mA or lower than 3.8 mA. Both values are configurable by the user through the on-board push buttons.

2.10 - Temperature ranges

Electronic unit: -40°C ÷ +85°C

Electronic unit with LCD display and Viton seals: -20°C ÷ +65°C

2.11- Storage Temperature

-50°C ÷ +85°C; electronic unit with LCD display: -40°C ÷ +65°C

2.12 - Starting time (Warm-up)

maximum 15s.

2.15- Accuracy

±0,075%

2.16 - Stability

±0.1%

2.17 - Temperature drift

Total error ±0.08% of the maximum range value, every 10°C

2.18 - Static pressure drift

±(0,05%URL + 0.075%Span)/10MPa

2.19 - Massima pressione

The maximum pressure values change as a function of the ordered code:

“B/C/L” - 1MPa

“D/M” - 4MPa

“F/O” - 15MPa

“G” - 20MPa

“H/I” - 50MPa

2.20 - Overpressure effect

±0.1% x Span / 10MPa

2.21 - Installation position influence

Zero deviation up to 0.4KPa, adjustable via calibration, for rotations of 90° relative to the sensor diaphragm plane.

2.22 - Materiali di costruzione

Sensor body: SS316L

Flanges: SS316L

Isolating diaphragm according to the model: SS316L; Hastelloy C;

Nuts and bolts: SS304

Process connections: SS316

Filling fluid according to the model: silicone oil, fluorinated oil

Seals in the process according to the model: NBR (nitrile rubber Perbunan®); FKM (Viton); PTFE (teflon)

Electronics housing: aluminum with epoxy paint

Electronics housing seals: NBR (nitrile rubber Perbunan®)

Unit code nameplate: SS304

2.23 - Process Connections

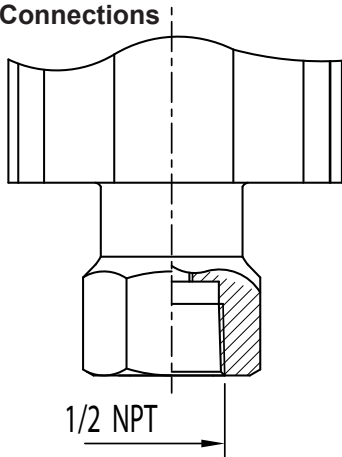

1/2 "NPT female threaded (cod.1 std.). Version for range cod. F/G/H/I/O

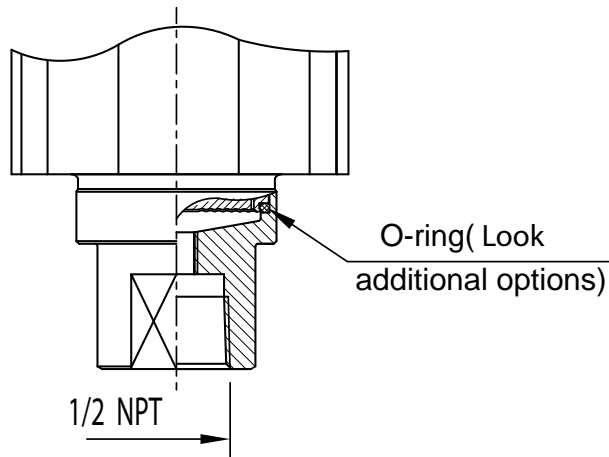

1/2 "NPT female threaded (cod.1 std.). Version for range cod. B/C/D/L/M

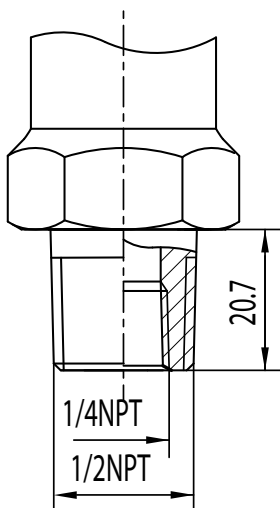

1/2" NPT male thread with 1/4" NPT female threaded hole (cod.2 std.)

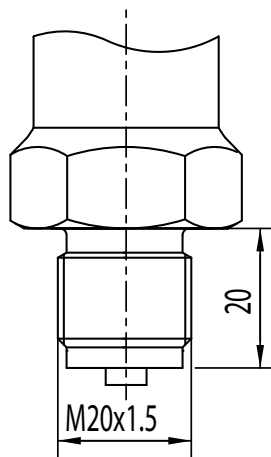

M20x1.5 male threaded (cod.3 std.)

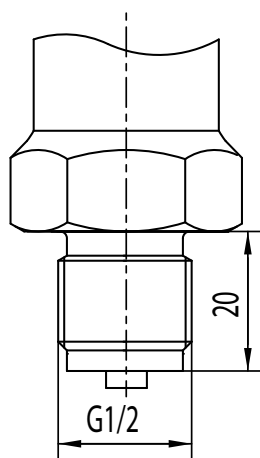

1/2" G male threaded (cod.4 std.)

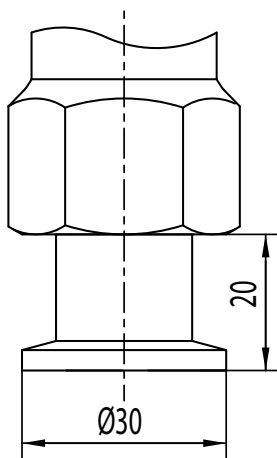

Vacuum connection ISO 2861; max.2.5bar (cod.5 opz.)

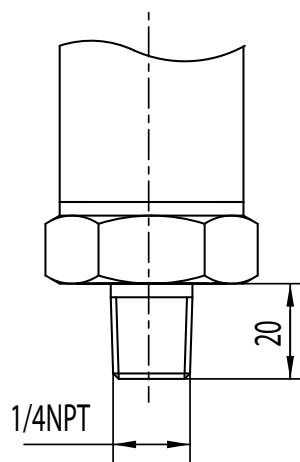

1/4"NPT male thread (cod.6 std.)

2.24 - Electrical connections

M20x1.5 cable glands. Grounding terminal for cables up to 2.5mm²

2.25- Weight

1.6Kg excluding accessories

3. Mechanical Installation

3.1 - Mounting on 2" pipe or wall mounted - Option 1/2

3.1.1 - Mounting on horizontal 2" pipe (Fig. 3-1) and mechanical dimensions

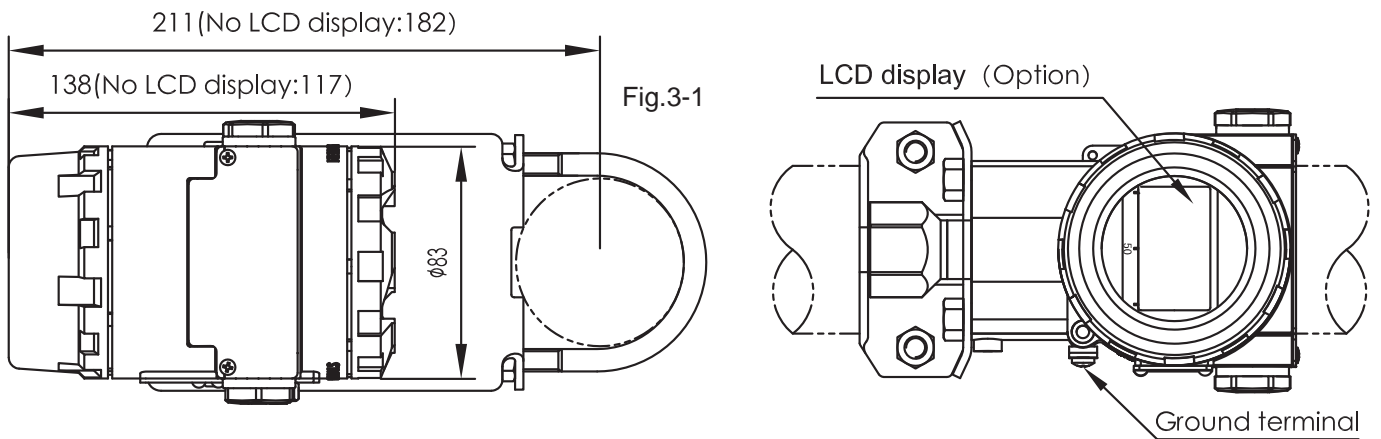

3.1.2 - Mounting on vertical 2" pipe (Fig. 3-2) and wall mount (Fig. 3-3)

Fig.3-2

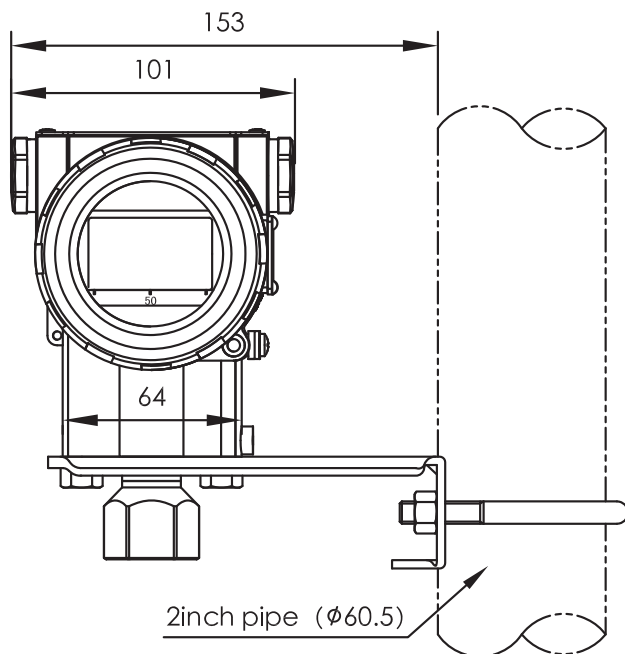
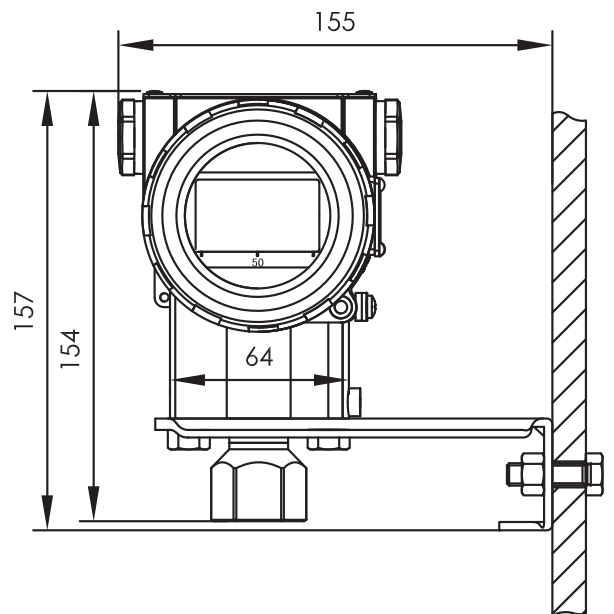

Fig.3-3



4 - Setup

4.1 Calibrations via Z and S buttons

The units are manufactured with default configurations. In the absence of a Hand Held Communicator or of a PC SW or of the display, to change the calibrations operate on the keys as shown below.

4.1.1 Range calibration

Press **S+Z** for 5 sec.

Apply the minimum pressure; hold down the **Z** button for 5 seconds until the current signal is automatically adjusted to 4mA (0%)

Apply the maximum pressure; hold down the **S** button for 5 seconds until the current signal is automatically adjusted to 20mA (100%)

4.2 Operating menu

When the unit **SPT** is equipped with its display (cod.1/2 opt.), is possible to configure and calibrate the **SPT** unit accessing the operating menu. The operating menu structure is shown in Fig. 4-1.

Press **Z** and **S** simultaneously

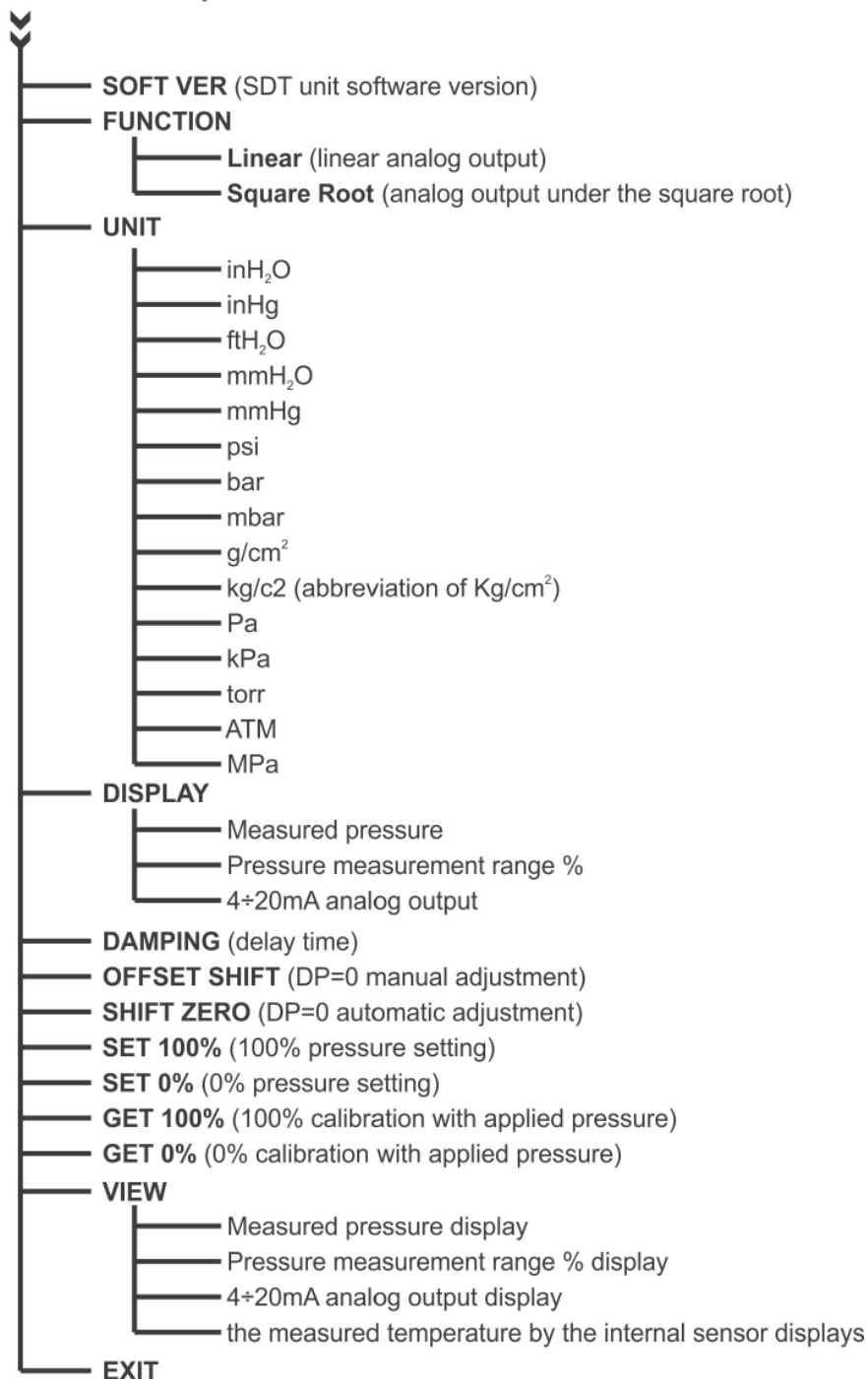

Fig.4-1

4.3 Access to the operating menu

When switched on, the display shows the start-up message system



Completed the boot process, the unit **SPT** will be set automatically in **RUN** mode, displaying the measurement of differential pressure as previously set.



To access the operating menu, press the **Z** and **S** simultaneously (fig. 4-2).

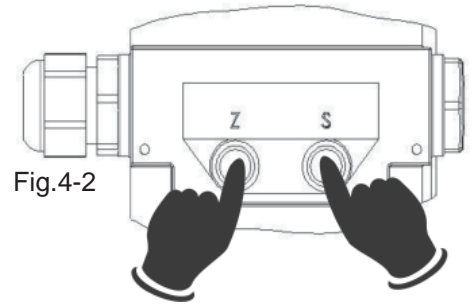

After the **S** and **Z** release, the word **EXIT** will be displayed. The below bar graph will continue to show the percentage value of the measuring range.

N.B. - After about 60 seconds, in the commands with **Z** and **S** absence, the system will automatically return to **RUN** mode..



Press **S** to scroll to the next parameter;

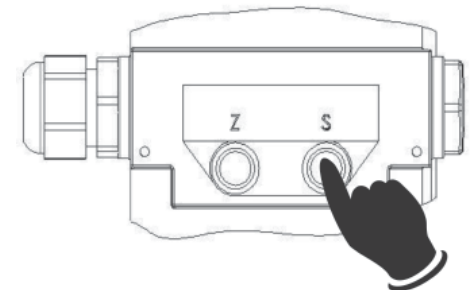

Press **Z** to scroll to the previous parameter;

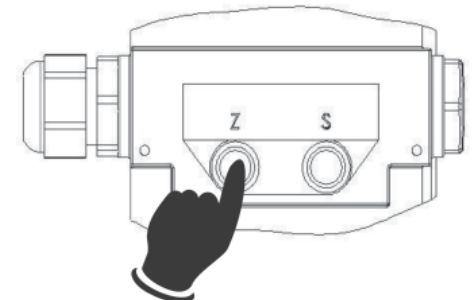

Z e S contemporaneamente per uscire dal menù operativo

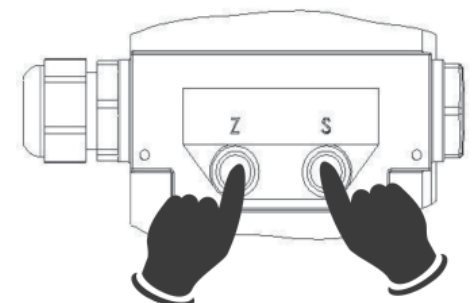
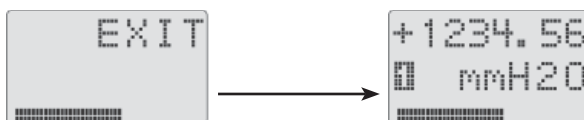

N.B. - The exit from the operating menu, by pressing **Z** and **S** at the same time, is possible only by the **EXIT** parameter.

4.3.1 SOFT VER

Software version

Press:

Z and **S** at the same time to access the parameter;

S to scroll to the next parameter;

Z to scroll to the previous parameter;

Displaying data of the **SPT** software version.

Press **Z** and **S** at the same time to exit the parameter



4.3.2 FUNCTION

4÷20mA analog output mode

Press:

Z and **S** at the same time to access the parameter;

S to scroll to the next parameter;

Z to scroll to the previous parameter;

With **Z** or **S** select the analog output mode:

LINEAR - linear analog output, the choice is highlighted on the display by the “/” symbol

SQUARE ROOT - uscita analogica sotto radice quadrata, the choice is highlighted on the display by the “√” symbol

Press 2 times **Z** and **S** at the same time to confirm the selection and exit the parameter

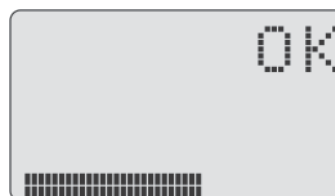
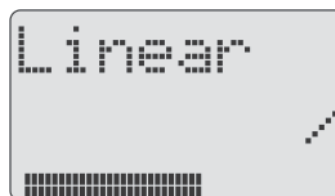

4.3.3 UNIT

Unità di misura della pressione

Press:

Z and **S** at the same time to access the parameter;

S to scroll to the next parameter;

Z to scroll to the previous parameter;

With **Z** or **S** select the pressure measure unit.

The available units measurement are:

inH₂O - inHg - ftH₂O - mmH₂O - mmHg - psi - bar - mbar - g/cm² -

Kg/cm² (abbreviated as kg/c2) - **Pa - kPa - torr - ATM - MPa**

Press 2 times **Z** and **S** at the same time to confirm the selection and exit the parameter

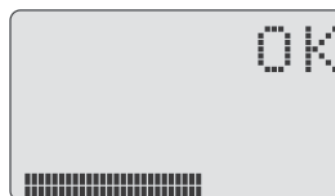

4.3.4 DISPLAY

Selecting the displaying in **RUN** mode.

Press:

Z and **S** at the same time to access the parameter;

S to scroll to the next parameter;

Z to scroll to the previous parameter;

With **Z** or **S** select the measurement to be displayed during **RUN** mode:

Is possible to select:

- measured pressure with its measurement unit; the choice is highlighted on the display with the number **1** on the bottom left

- range percentage of the pressure measurement; the choice is highlighted on the display with the number **2** on the bottom left

- 4÷20mA analog output signal value; the choice is highlighted on the display with the number **3** on the bottom left

Press 2 times **Z** and **S** at the same time to confirm the selection and exit the parameter

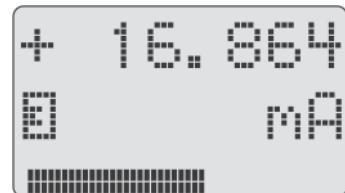
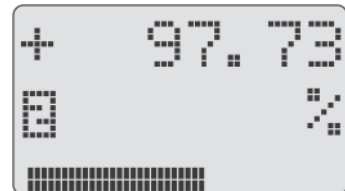
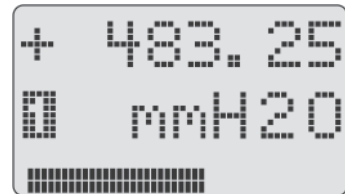

4.3.5 DAMPING

Delay time, in seconds, for the reading variations the of the pressure measurement.

Press:

Z and **S** at the same time to access the parameter;

S to scroll to the next parameter;

Z to scroll to the previous parameter;

With **S** move the cursor to select the digit.

With **Z** change the digit.

Press 2 times **Z** and **S** at the same time to confirm the selection and exit the parameter

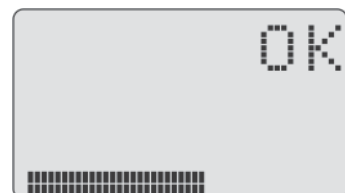
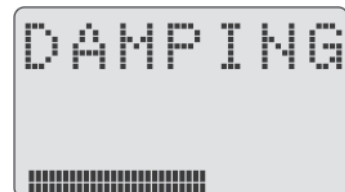

In the event that the value entered is not correct, will be displayed the error message and the parameter will not be modified.

Press **Z** and **S** at the same time to exit the parameter



4.3.6 OFFSET SHIFT

P zero offset Manual adjustment. Adjustment Range: -12.00% ÷ +12.00% on the range percentage corresponding to **P zero**

Press:

Z and **S** at the same time to access the parameter;

S to scroll to the next parameter;

Z to scroll to the previous parameter;

With **S** move the cursor to select the digit.

With **Z** change the digit.

Es.: range 0÷100kpa; OFFSET +5% = new range -5÷+95kPa

Es.: range 0÷100kpa; OFFSET -5% = new range +5÷105kPa

Es.: range -100÷100kpa; OFFSET +55% = new range -110÷90kPa

Es.: range -100÷100kpa; OFFSET -55% = new range -90÷110kPa

Press 2 times **Z** and **S** at the same time to confirm the selection and exit the parameter.

N.B. - This function is useful for manually correct the measurement offset caused by the mounting position (eg sensor inclined), when it is not possible to apply to the cells the **P zero** pressure

In the event that the value entered is not correct, will be displayed the error message and the parameter will not be modified.

Press **Z** and **S** at the same time to exit the parameter



4.3.7 SHIFT ZERO

P zero offset automatic adjustment.

Press:

Z and **S** at the same time to access the parameter;

S to scroll to the next parameter;

Z to scroll to the previous parameter;

Press **Z** and **S** at the same time to exit the parameter

N.B. - This function is useful to automatically correct the offset measurement caused by the mounting position (eg sensor inclined), when is possible to apply to cells the **P zero** pressure



4.3.8 SET 100%

Manual pressure setting corresponding to the **100%** measuring range.

Press:

Z and **S** at the same time to access the parameter;

S to scroll to the next parameter;

Z to scroll to the previous parameter;

With **S** move the cursor to select the digit.

With **Z** change the digit.

N.B. - The displayed measure unit depending on the **UNIT** parameter setting in section 4.3.3



Press 2 times **Z** and **S** at the same time to confirm the selection and exit the parameter



In the event that the value entered is not correct, will be displayed the error message and the parameter will not be modified.
Press **Z** and **S** at the same time to exit the parameter



4.3.9 SET 0%

Manual pressure setting corresponding to the **0%** measuring range.

Press:

Z and **S** at the same time to access the parameter;

S to scroll to the next parameter;

Z to scroll to the previous parameter;



With **S** move the cursor to select the digit.

With **Z** change the digit.

N.B. - The displayed measure unit depending on the **UNIT** parameter setting in section 4.3.3



Press 2 times **Z** and **S** at the same time to confirm the selection and exit the parameter

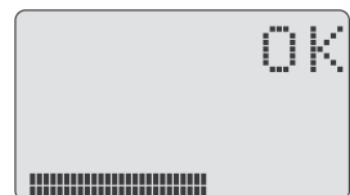

In the event that the value entered is not correct, will be displayed the error message and the parameter will not be modified.

Press **Z** and **S** at the same time to exit the parameter



4.3.10 GET 100%

Calibration of the pressure corresponding to the **100%** measuring range with the maximum pressure applied. The current signal is automatically adjusted to 20mA.

Press: **Z** and **S** at the same time to access the parameter;

S to scroll to the next parameter;

Z to scroll to the previous parameter;

Press **Z** and **S** at the same time to exit the parameter

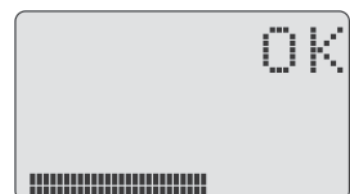

4.3.11 GET 0%

Calibration of the pressure corresponding to the **0%** measuring range with the minimum pressure applied. The current signal is automatically adjusted to 4mA.

Press: **Z** and **S** at the same time to access the parameter;

S to scroll to the next parameter;

Z to scroll to the previous parameter;

Press **Z** and **S** at the same time to exit the parameter



4.3.12 VIEW

Measurement display without changing the display in **RUN** mode (**DISPLAY** parameter, 4.3.4).

Press: **Z** and **S** at the same time to access the parameter;

S to scroll to the next parameter;

Z to scroll to the previous parameter;

With **Z** or **S** select the measurement to be displayed:

Is possible to select:

- measured pressure with its measurement unit; the choice is highlighted on the display with the number **1** on the bottom left
- range percentage of the pressure measurement; the choice is highlighted on the display with the number **2** on the bottom left
- 4÷20mA analog output signal value; the choice is highlighted on the display with the number **3** on the bottom left
- temperature measured by the sensor inside the cell; the choice is highlighted on the display with the number **4** on the bottom left
- Not active function
- Parameter for the headquarters exclusive use

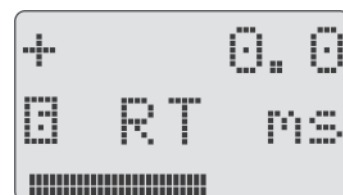
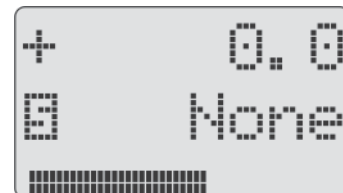
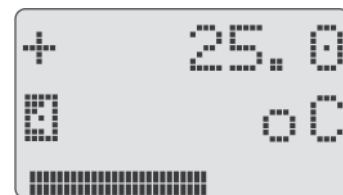

- Parameter for the headquarters exclusive use



- Parameter for the headquarters exclusive use



Press 2 times **Z** and **S** at the same time to confirm the selection and exit the parameter

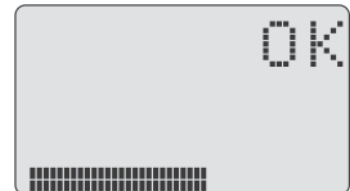

6. Installation

SPT transmitters can be used for flow, liquid level, or other applications requiring accurate measurement of pressure. The accuracy of a measurement depends to a great extent on proper installation of the **SPT** and impulse piping, so that correct installation is very important. The transmitters are often installed in harsh environments due to process and economic consideration. Thus the transmitters should be located to minimize the effects of temperature gradients and fluctuations and to avoid vibration and mechanical shock.

! CAUTION !

It is not allowed for the medium to ice because it would damage the isolating diaphragm, and destroy the transmitter

6.1 - Process Connection

The following information is very important for properly mounting a transmitter..

6.1.1 - Location

Proper transmitter location with respect to the process pipe depends on the process material. Consider the following to determine the best location:

- a) Keep corrosive or hot process material away from the transmitter
- b) Avoid sediment deposit in the impulse piping
- c) Keep connection piping as short as possible
- d) Install connection piping at temperature gradients and fluctuations less changing place. Keep connection piping

6.1.2 - Error minimization

The connecting pipes between the process and the transmitter transmit the pressure between the two points. The following conditions may cause transmission pressure errors:

- 1) Line losses
- 2) Line resistances caused by: bottlenecks; valves separation; the insufficient transducer/process pipes connecting diameter
- 3) Fluid presence in a gas line
- 4) Gas presence in a fluid line
- 5) Variations in product density between the transmitter and the process connection

To minimize the error take the following steps:

- 1) The transducer/process pipes connecting length the must be reduced to a minimum
- 2) For gas, the tubes connection the transducer / process must have a positive slope at least 1/12 toward the process connection
- 3) For liquids and vapor, the transducer/process connecting pipes should have the negative slope at least 1/12 toward the process connection
- 4) Avoid the following line points: high for liquids lower for gas
- 5) Maintain a constant temperature between the transmitter and the process connection
- 6) Use connecting pipes with a sufficient diameter to prevent the line resistance
- 7) Bleed the presence of any gas from the pipes with fluid
- 8) Fill the transducer/process connecting pipes at the same level, when using a liquid separation in the gas lines
- 9) Avoid purging through the transmitter. Make the purge connection close to the process taps and purge through equal lengths of the same size pipe

6.2 - Mechanical mounting

SPT transmitters can be mounted directly at the point of measurement, can be mounted against a wall, or with the use of a mounting bracket- to a 2" (about Ø60 mm) pipe.

6.3 - Electrical connections

The connection terminal is housed in the transmitter housing separate compartment. Unscrew the cover placed over the "FIELD TERMINALS" word to access the terminal. For the electrical connection, the analog signal cables is sufficient, because the SPT is a transmitter with two-wire technology. The connection cable must be a shielded twisted pair cable with a cross section of $2 \times 0.5 \text{ mm}^2$ also not be channeled with power cables.

The cable glands for cable entry to the transmitter housing should be sealed or blind (M20x1.5) with a sealant to prevent the ingress of humidity into the housing. If the connection is not tight, the cable gland must be facing down to allow drainage of any condensation forming.

The electrical signal may be transmitter or ungrounded.

WARNING - Because the transmitter is capacitance-coupled to ground, insulation resistance should not be checked with high voltage meter. No more than 45V should be used for circuit check.

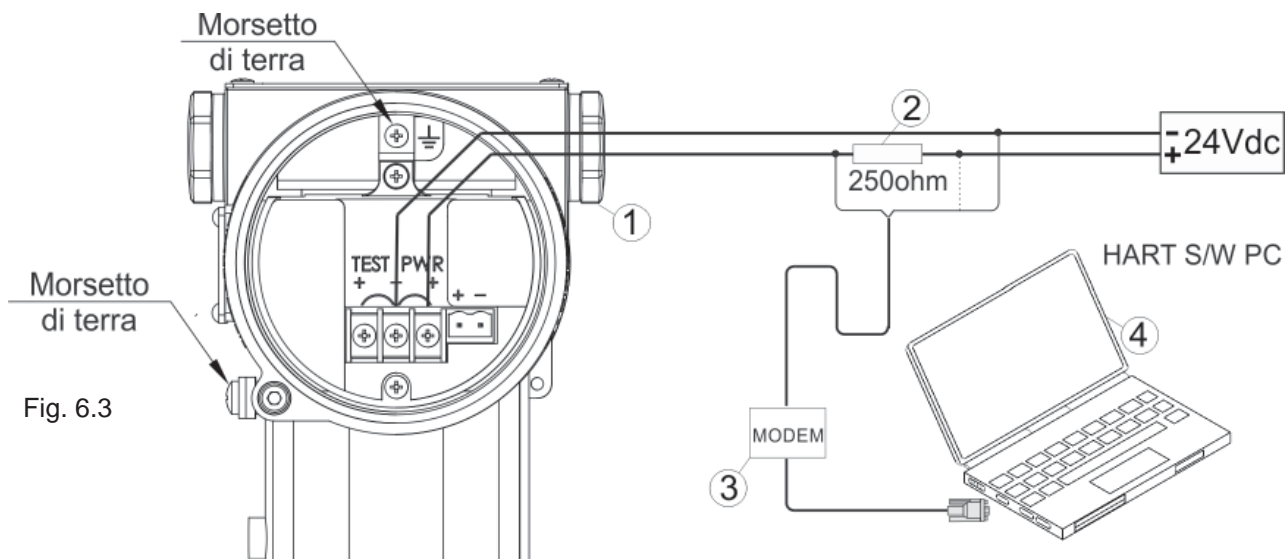

7. Maintenance

Normally frequent system maintenance works are not necessary, because in the transmitter **SPT** there are no moving parts. This section describes:

- The test methods for the sensor
- The procedure to disassemble the transmitter
- The procedure to assemble the transmitter

7.1 - Sensor Test

If there is a infiltration of liquid, or insulation diaphragm is damaged, the sensor must be replaced. The sensor replacement operation can not be performed in the field, for which it is necessary disassembling the transmitter and perform the failure sensor replacement operation in a adequate local.

7.2 - Disassembly Procedure

7.2.1 - Electronic parts

WARNING - During the following operations take all necessary precautions to avoid electrostatic discharge and make sure that the transmitter does not have the power supply switched on.

- 1) Unscrewing the two screws on the cover of the display, it is possible:
 - a) rotate the display by 90°, or 180°, or 270°
 - b) replace the display unit
 - c) replace the electronics unit
 - d) disconnect the flat electrical cable between the electronic unit and the sensor
- 2) Unscrewing the two screws on the terminal box cover you can replace the electronic control unit integrated in the terminal box

7.2.3 - Sensor

- 1) Unscrew the two screws of the display cover and disconnect the electronic unit from the sensor flat electrical cable
- 2) Fully unscrew the socket head placed under the "FIELD TERMINALS" word
- 3) Unscrew the sensor from the housing, taking care not to damage the isolation diaphragm or the flat electrical cable to connection to the electronic unit.
- 4) The sensor body is a watertight block, so it is not possible to disassemble other parts of it

7.3 - Reassembly procedure

7.3.1 - Preparation

- 1) Inspect all O-rings and replace if necessary
- 2) Put some silicone grease on the o-ring for a better seal

7.3.2 - Sensor

- 1) Insert the flat electrical cable of the sensor into the housing
- 2) Put the sealant retaining compound on the sensor threads to make sure it does not happen humidity infiltration from it
- 3) Screw the sensor and make sure the o-ring is in the correct position
- 4) Make sure that the slot found on the sensor body, for locking with the allen screw, has reached the correct position
- 5) Lock the housing by tightening the socket head placed under the "FIELD TERMINALS" word.

7.3.3 - Electronic parts

- 1) Check that the electronic circuits are clean
- 2) Make sure that the the male and female connectors in the housing, and in the circuits, do not show anomalies (dirt, folds, ..)
- 3) Insert the sensor flat cable connector into the connector on the electronic circuit. Observe the polarity of insertion
- 4) Insert the electronics in the housing, making sure that:
 - a) the two male connectors, which are present in the housing, fit perfectly in the two female connectors present on the electronics. Operation facilitated by the female connectors funnel shape.
 - b) the sensor flat cable is positioned in the housing hollow section
 - c) the two holes for the screws are aligned with the housing threaded holes
- 5) Insert the display, orienting it according to the need of installation, and tighten the two screws

7.3.4 - Advice

- 1) The display can be rotated 90 °, 180 °, 270 ° for easy reading, as indicated in step 7.2.2/1.a
- 2) The o-ring seal should be checked each time a opening and/or closing maneuver is performed.
- 3) The display housing end cap glass should not be removed for any reason, because the warranty seal would be compromised

7.3.5 - Mechanical parts replacing

All mechanical parts are replaceable without the need to recalibrate the system

8. Troubleshooting

The procedures described here, are used to identify the causes of system malfunction, and to suggest possible measures to be taken to eliminate the inconvenience. In the event that, after following the procedures described here, does not resolve the inconvenience, please contact our customer service.

8.1 - High analog output

The causes and possible solutions are:

- 1) Check the restrictions on the primary element (eg. Holes free)
- 2) Check in the connection pipes that:
 - a) there are no sealing leak, or holes on the pipe surface or inside obstruction elements
 - b) check that the interception valves are fully open and the bypass valves are closed
 - c) there is no gas presence in the fluid processes, and conversely, there is no fluids presence within the gas process
 - d) there are no sediment deposits inside the process connection flanges
 - e) that the fluid density present in the process and the sensor is identical
- 3) Internal electrical connections:
 - a) make sure that all connection points are clean
 - b) make sure that the supply voltage is 12÷42Vdc
- 4) Faulty electronic parts:
 - b) replace the fault electronic component
- 5) Sensor module:
 - a) Refer to the “sensor module” section
- 6) Power supply unit:
 - a) check the supply voltage

8.2 - Low or absent analog output

The causes and possible solutions are:

- 1) Primary elements:
 - a) check check check the primary elements installation and the conditions
 - b) check for any changes in process fluid properties and the arising consequences
- 2) Line electrical connections (loop):
 - a) check the power supply
 - b) verify that there are no grounding points on the line (loop)
 - c) check the connection line polarity (loop)

!WARNING!

The supply voltage must not be greater than 42V during the loop test.

- 3) Connecting pipes:
 - a) check that the pressure connection is correct
 - b) check that there are no leaks or occlusions
 - c) check that there is no gas presence within processes with fluids

- d) check that there is not sediment presence in the process connection flanges
 - e) check that the interception valves are fully open and the bypass valves are closed
 - f) check that the fluid density present in the process and the sensor is identical
- 4) Internal electrical connections:
- a) check that the flat electrical cable between the electronic unit and the sensor
 - b) check that all connection points are intact and clean
- 5) Electronic Parts in operating fault:
- b) replace the electronic component in operating anomaly
- 6) Sensor module:
- a) Refer to the "sensor module" section

8.3 - Unstable output

The causes and possible solutions are:

- 1) Line electrical connections (loop):
- a) check that there are no intermittent points to ground, or short circuit or line interruptions (loop)
 - b) check the power supply voltage

!WARNING!

The supply voltage must not be greater than 42V during the loop test.

- 2) For oscillations in the average:
- a) set an appropriate value for the delay time
- 3) Connecting pipes:
- a) check that there is no gas presence within processes with fluids, conversely, check that there is no fluids presence within processes with gas
- 4) internal electrical connections:
- a) check that there are no intermittent points to ground, or short circuit or line interruptions
 - b) check that all connection points are intact and clean
 - c) check the sensor module grounding
- 5) Electronic parts in operating fault:
- b) replace the electronic component in operating fault
- 6) Sensor module:
- a) Refer to the "sensor module" section

8.4- Communication Absence

The causes and possible solutions are:

- 1) check that the supply voltage is correct
- 2) check that the load resistance on the line is correct (fig.6.3)
- 3) replace any faulty electronic parts