

# Rsmag

electromagnetic induction flow measurement with data logger (opt.)

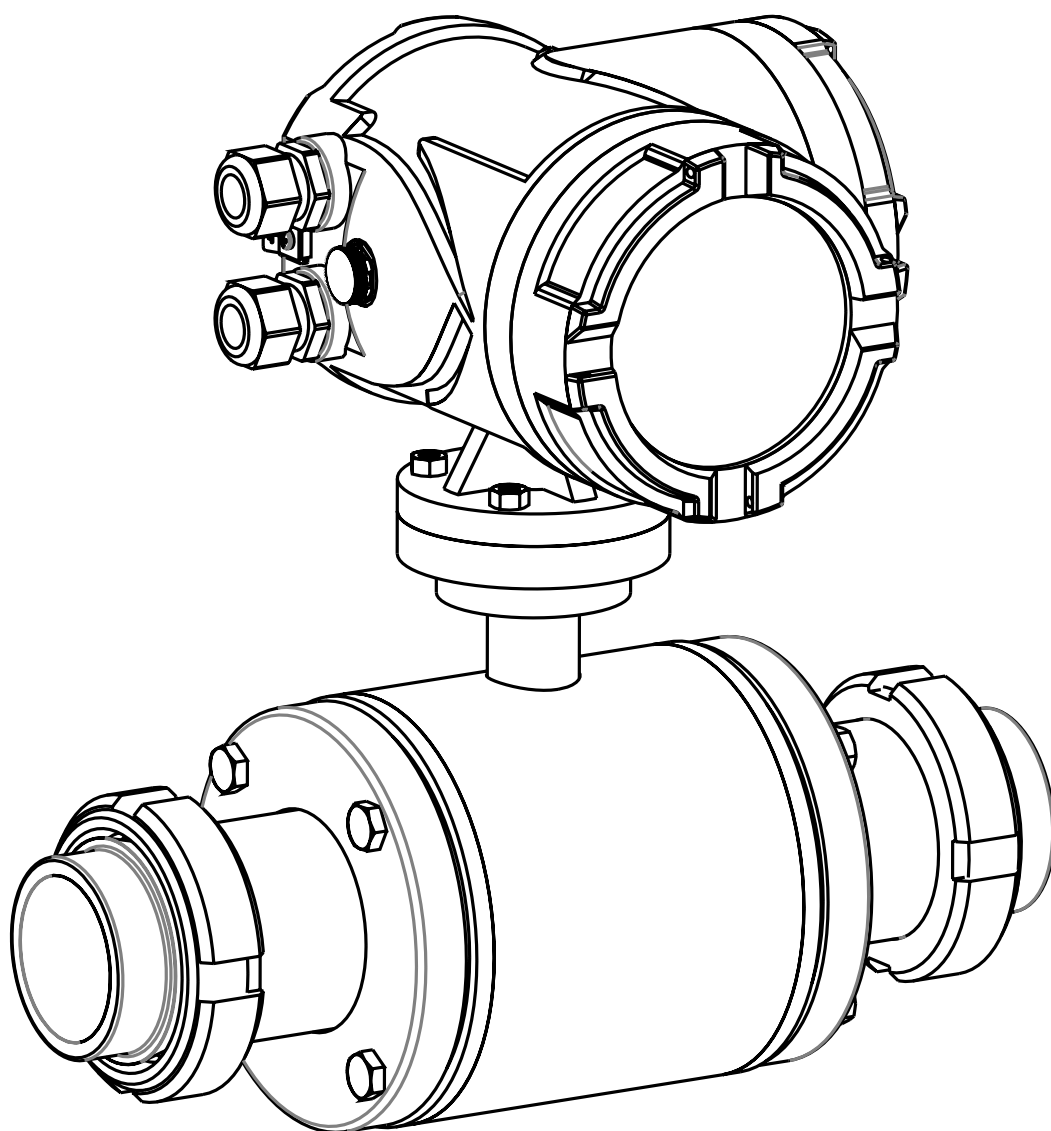

technical documentation EN Rev. of 11/05/2023

# CONTENTS

---

<b>1-WARRANTY</b>	page 3
<b>2-CALIBRATION CERTIFICATE</b>	page 3
<b>3-PRODUCT</b>	page 4
<b>4-PERFORMANCE SPECIFICATIONS</b>	page 5
<b>5-FLOW RANGE</b>	page 6
<b>6-DIMENSION</b>	page 8
<b>7-INSTALLATION</b>	page 11
<b>8-ELECTRICAL CONNECTIONS</b>	page 18
<b>9-LOCAL OPERATOR INTERFACE (LOI)</b>	page 26
<b>10-PROGRAMMING</b>	page 30
<b>11-TROUBLESHOOTING</b>	page 57
<b>12-FACTORY TEST AND QUALITY CERTIFICATE</b>	page 60

## 1-WARRANTY

---

Products supplied by SGM LEKTRA are guaranteed for a period of 12 (twelve) months from delivery date according to the conditions specified in our sale conditions document.

SGM LEKTRA can choose to repair or replace the Product.

If the Product is repaired it will maintain the original warranty terms, whereas if the Product is replaced it will have 12 (twelve) months of warranty.

The warranty will be null if the Client modifies, repair or uses the Products for other purposes than the normal conditions foreseen by instructions or Contract.

In no circumstances shall SGM LEKTRA be liable for direct, indirect or consequential or other loss or damage whether caused by negligence on the part of the company or its employees or otherwise howsoever arising out of defective goods

## 2-CALIBRATION CERTIFICATE

---

All the electromagnetic flowmeter are tested by 3 point rigs calibration.

The producer releases a document on letterhead certifying the average error of the 3-point calibration.

The calibration certificate is supplied with the unit.

The company archives the test data of each electromagnetic flowmeter.

The calibration rig is certificated by N.I.M. (National Institute of Metrology), which is internationally recognized by B.I.P.M. (Bureau International des Poids et Metrologie) and complies with NTC ISO IEC 17025 standard.

All calibrations are made in accordance to EN 45001 standards and with an accuracy better than 99.97%

### 3-PRODUCT

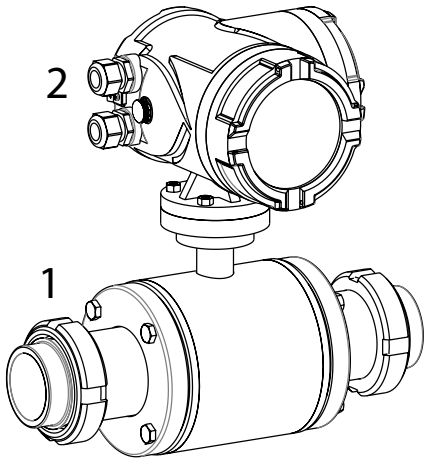

#### COMPACT VERSION

- 1. Sensor
- 2. Converter

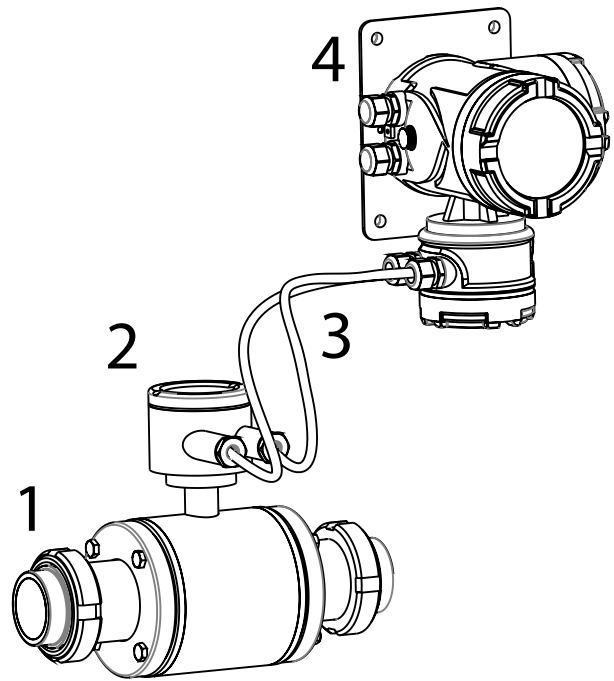

#### REMOTE VERSION

- 1. Sensor
- 2. Connection housing
- 3. Connection cables
- 4. Converter, wall mouting

#### 3.1 - IDENTIFICATION

Each meter has an adhesive identification plate on which are the meter main data. The following picture describes the information and data on the identification plate.

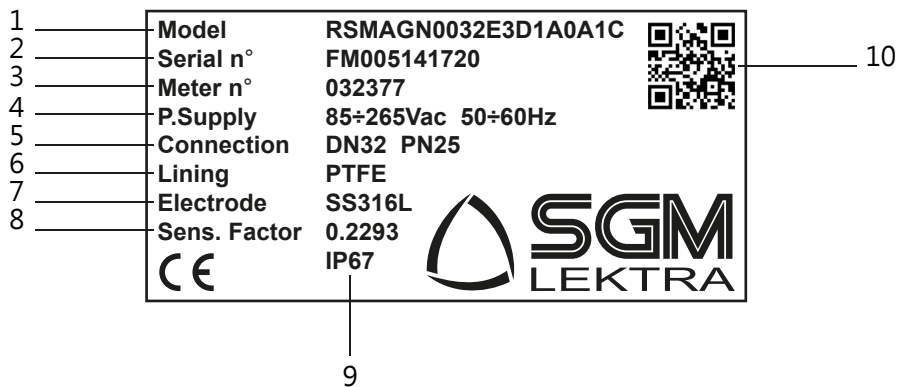

- 1. Product code
- 2. Serial number
- 3. Production batch
- 4. Power supply

- 5. Process connection
- 6. Lining material
- 7. Electrodes material
- 8. Sensor factor

- 9. Protection
- 10. QR code, connecting a product web page

## 4-FEATURES

---

### Flow rate range

Rsmag is able to process signals from fluids with flow rates of up to 10m / s in both directions (bidirectional meter).

### Range dimension / lining material

PFA DN15 ÷ DN200

### Sensor material

SS304

### Housing material

epoxy painting aluminium

### Electrodes material

SS316L - Hastelloy C - Titanium - Tantalum

### Measure range

<0,3m<sup>3</sup>/h ÷ >1100m<sup>3</sup>/h

### Accuracy

±0,5% standard; ±0,2% optional

### Repeatability

±0,1%

### Fluid conductivity

>5µS/cm. / >20µS/cm. with demineralized water

### Power supply

85÷265Vac, 24Vac/dc, 12Vdc.

### Consumption

6W, max. 8W.

### Sensor Pipe Temperature Limits

Remote version operating temperature: <= 180°C

Compact version operating temperature: <= 100°C

Storage temperature: -40÷85°C

### Converter temperature range

-20÷60°C

### Communication protocol

Modbus

### Data Logger (opt.)

Internal data logger to USB pen drive for flow measurements and analog inputs storing;  
the measurement storage interval can be set from 15 to 3600 seconds

### Output

4÷20mA: 0÷500Ω

Frequency output: 0,1÷10000 Hz

Pulse output: open collector galvanically isolated

Alarm output: 2 relays, 3A 230Vac N.O.

### Input signals

Rsmag has 2 active analog inputs at 24Vdc for 2-wire transmitters connection (eg. Temperature or pressure) and 1 digital input for an external contact connection for the integrated batch function restart and for partial totalizer management.

### Reverse Flow

Allows measure and totalization of reverse flow.

### Output Testing

Relays output: Transmitter can switch relays at testing value.

Current Source: Transmitter can be commanded to supply a specified test current between 4.0 and 20.0 mA.

Frequency Source: Transmitter can be commanded to supply a specified test frequency between 1 and 10000 Hz.

Pulse Output: Transmitter can force the sending of a counting pulse.

### Low Flow Cutoff

Adjustable. Below selected value, instantaneous flow and outputs are driven to the zero flow rate signal level.

### Humidity Limits

0-100% RH to 150 °F (65 °C), not condensing.

### Damping

Adjustable between 1 and 99 seconds.

### Compact version IP rating

IP67

### Remote version IP rating

sensor IP67 / IP68 (by request) - converter IP67

### Anti-condensation filter

Anti-condensation filter installed on converter

# 5-FLOW RANGE

## 5.1 - FLOW RANGE GRAPHIC

Flow range from DN3 to DN500 (starting from DN10)

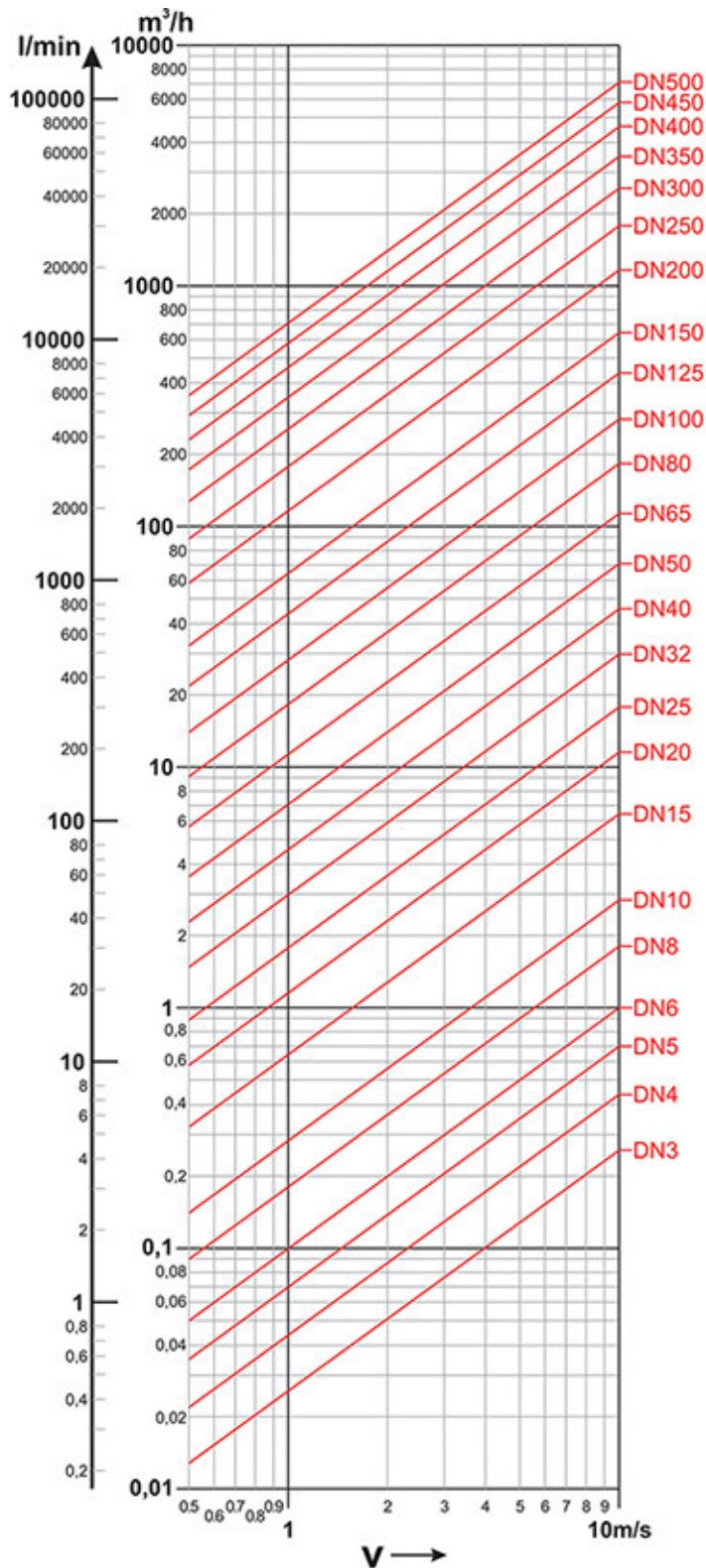

## 5.2 - FLOW RANGE TABLES

DN10 ÷ 200	
DN (mm)	Range: Minimum (0,5 m/s) / Maximum (10 m/s)
10	0.14 ÷ 2.9 m <sup>3</sup> /h
15	0.3 ÷ 6 m <sup>3</sup> /h
20	0.5 ÷ 12 m <sup>3</sup> /h
25	0.6 ÷ 18 m <sup>3</sup> /h
32	1 ÷ 30 m <sup>3</sup> /h
40	1.8 ÷ 42 m <sup>3</sup> /h
50	3 ÷ 66 m <sup>3</sup> /h
65	5.8 ÷ 120 m <sup>3</sup> /h
80	8.9 ÷ 180 m <sup>3</sup> /h
100	11 ÷ 282 m <sup>3</sup> /h
125	20 ÷ 450 m <sup>3</sup> /h
150	30 ÷ 600 m <sup>3</sup> /h
200	50 ÷ 1100 m <sup>3</sup> /h

## 5.3 - LOAD LOSS

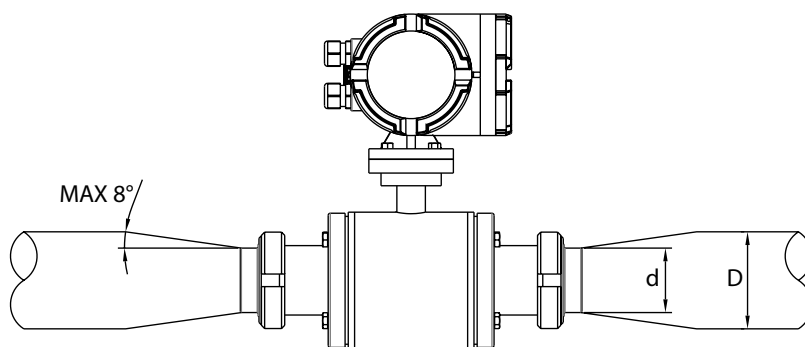

Adaptation cones

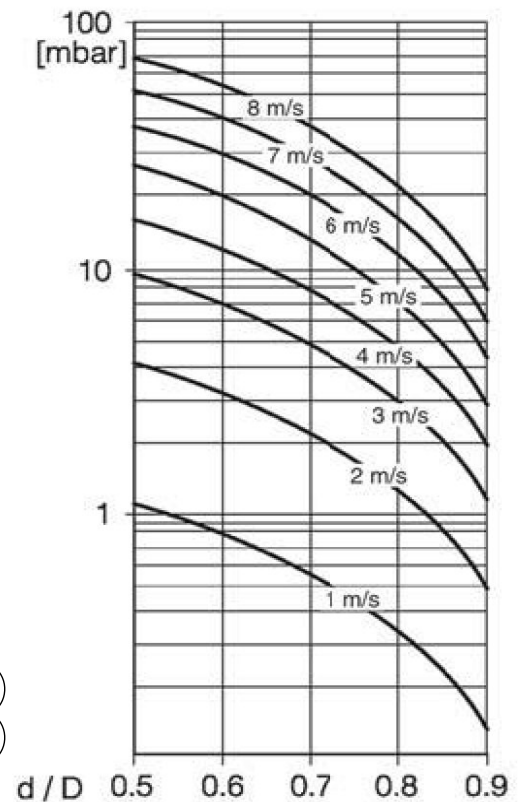

## 6-DIMENSIONS

### 6.1 - REMOTE VERSION CONVERTER

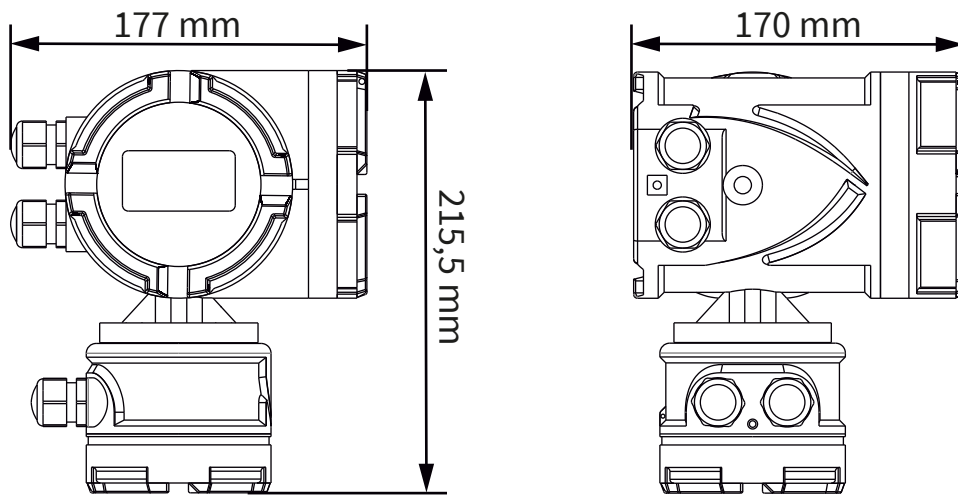

### 6.2 - WALL MOUNTING REMOTE VERSION CONVERTER

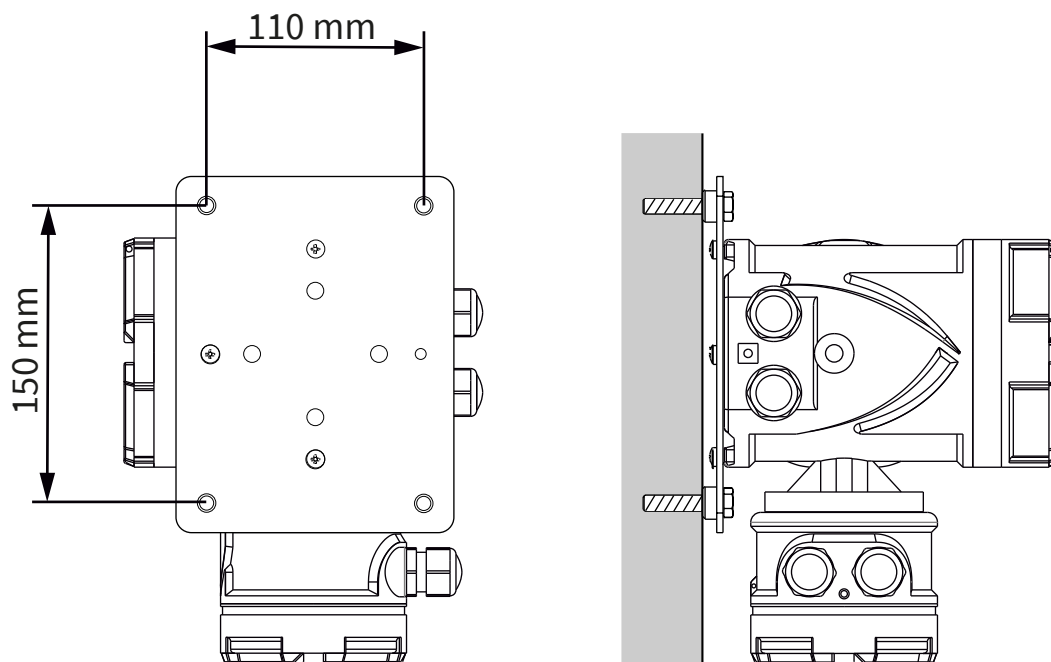



6.3 OVERALL DIMENSIONS VERSION WITH DIN11851 PN25 CONNECTIONS

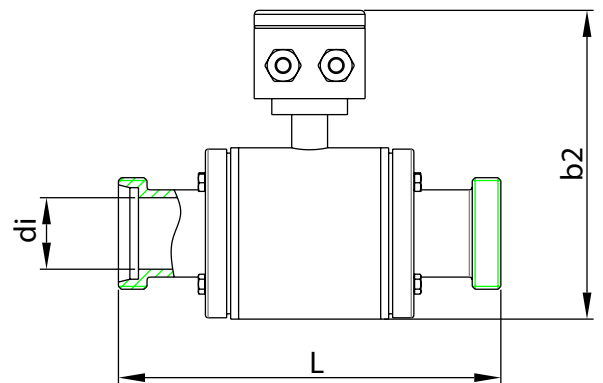
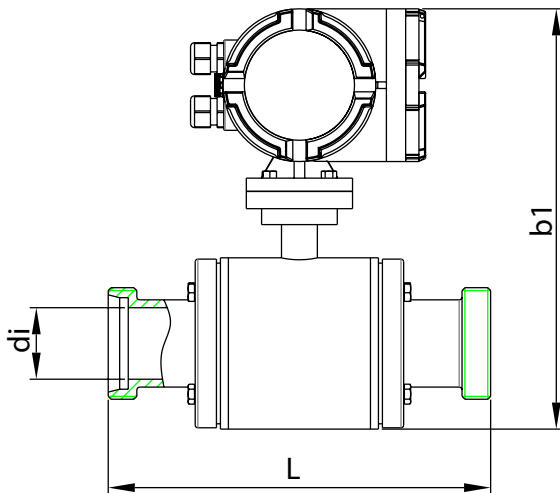

DN (mm)	di (mm)	L (mm)	b1 (mm)	b2 (mm)
10	10	172	290	210
15	16	200	272	193
20	20	200	280	200
25	26	200	280	200
32	32	200	290	210
40	38	200	290	210
50	50	200	305	225
65	66	250	310	232
80	81	250	330	252
100	100	250	355	275
125	125	300	380	300
150	150	300	415	335

Tabella DIN 11851

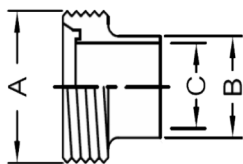

SIZE	A (mm)	B (mm)	C (mm)
10	28	18	12,2
15	34	19	16
20	44	23	20
25	52	29	26
32	58	35	32
40	65	41	38
50	78	53	50
65	95	70	66
80	110	85	81
100	130	104	100
125	160	129	125
150	190	154	150

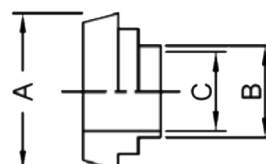

SIZE	A (mm)	B (mm)	C (mm)
10	22	18	12,2
15	28	19	16
20	36	23	20
25	44	29	26
32	50	35	32
40	56	41	38
50	68	53	50
65	86	70	66
80	110	85	81
100	121	104	100
125	150	129	125
150	176	154	150

## 6.4 OVERALL DIMENSIONS VERSION WITH CLAMP CONNECTIONS DIN32676 PN16

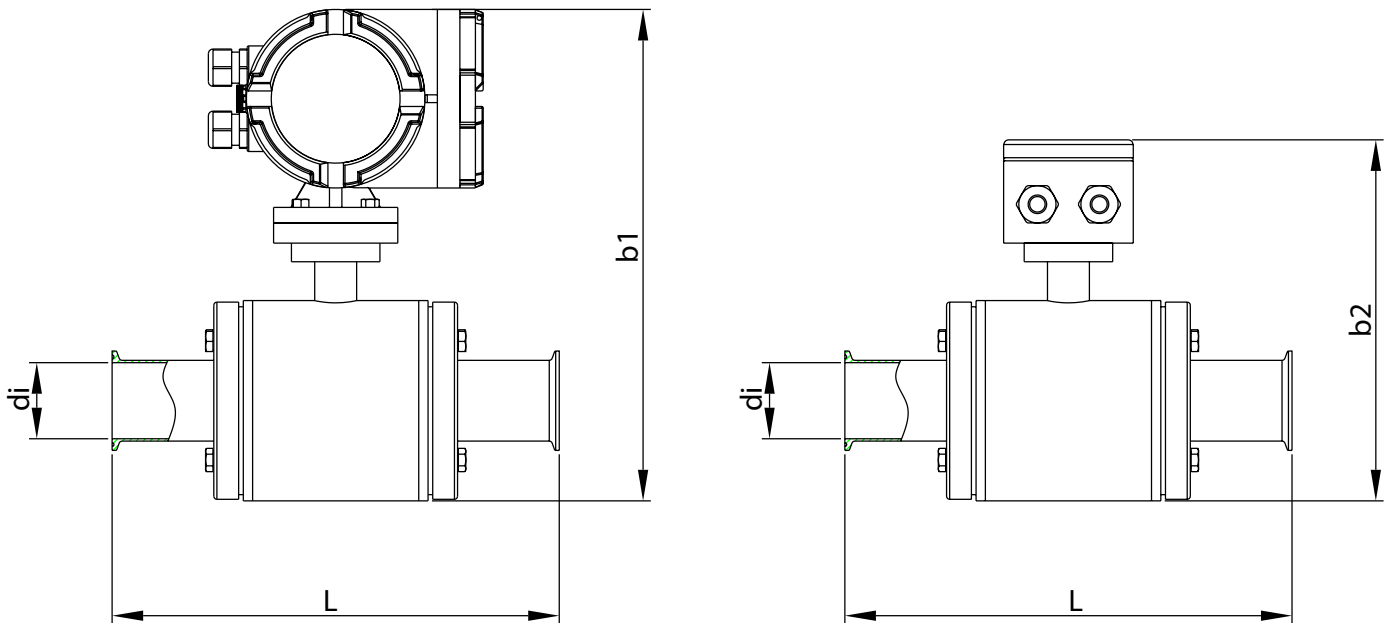

DN (mm)	di (mm)	L (mm)	b1 (mm)	b2 (mm)
10	10	172	290	212
15	15	200	272	193
20	19	200	280	200
25	25	200	280	200
32	31	200	290	210
40	36	200	290	210
50	49	200	305	225
65	66	250	310	232
80	81	250	330	252
100	100	250	355	275
125	125	300	380	300
150	150	300	415	335
200	200	350	455	378

Tabella CLAMP DIN32676

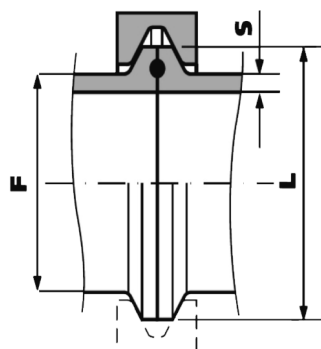

SIZE	L mm	F mm	Smm	ø int.
10	34.0	12	1.5	9
15	34.0	18	1.5	15
20	34.0	22	1.5	19
25	50.4	28	1.5	25
32	50.4	34	1.5	31
40	50.4	40	1.5	37
50	64.0	52	1.5	49
65	90.9	70	2.0	66
80	106.0	85	2.0	81
100	118.8	104	2.0	100
125	155.0	129	2.0	125
150	183.0	154	2.0	150
200	233.5	204	2.0	200

## 7-INSTALLATION

### 7.1 - SAFETY MEASURE

Instructions and procedures in this section may require special precautions to ensure the safety of the personnel performing the operations. Information that raises potential safety issues is indicated by a warning symbol. Please refer to the following safety messages before performing an operation preceded by this symbol. ⚠

### 7.2 - WARNINGS

#### 7.2.1 - Explosions could result in death or serious injury

- Verify that the operating atmosphere of the sensor pipe and transmitter is consistent with the appropriate hazardous locations certifications.
- Do not remove the transmitter cover in explosive atmospheres when the circuit is alive.

#### 7.2.2 - Failure to follow safe installation and servicing guidelines could result in death or serious injury

- Make sure only qualified personnel perform the installation.
- Do not perform any service other than those contained in this manual unless qualified.

#### 7.2.3 - High voltage that may be present on leads could cause electrical shock

- Avoid contact with leads and terminals.

### 7.3 - PRE-INSTALLATION

There are several pre-installation steps that make the installation process easier.

They include identifying the options and configurations that apply to your application, setting the hardware switches if necessary, and consideration of mechanical, electrical, and environmental requirements.

Please remember that the sensor pipe liner is vulnerable to handling damage.

Never place anything through the sensor pipe for the purpose of lifting or gaining leverage.

Damaged liner can render the sensor pipe useless.

#### 7.3.1 - Identify Options and Configurations

Standard application of the Rsmag includes control of the sensor pipe coils and one or more of the following configurations or options:

- 4÷20mA output
- Pulse output
- Alarm output
- Data logger

Be sure to identify the options and configurations that apply to your situation, and keep a list of them nearby during the installation and configuration procedures.

#### 7.3.2 - Mechanical Considerations

The mounting site for the Rsmag Integral Mount Transmitter should provide enough room for secure mounting, easy access to the conduit ports, full opening of the transmitter covers, and easy readability of the local operator interface (LOI) screen. The LOI can be rotated in 90° increments.

#### 7.3.3 - Lift

The flowmeter can be lifted using the lift as shown in following pictures.

The safe load and measure for the lift should reach to the relative requirement.

Don't lift the flowmeter using the rope to tie the connection between the sensor and the transmitter (compact version) or the connecting box (remote version)

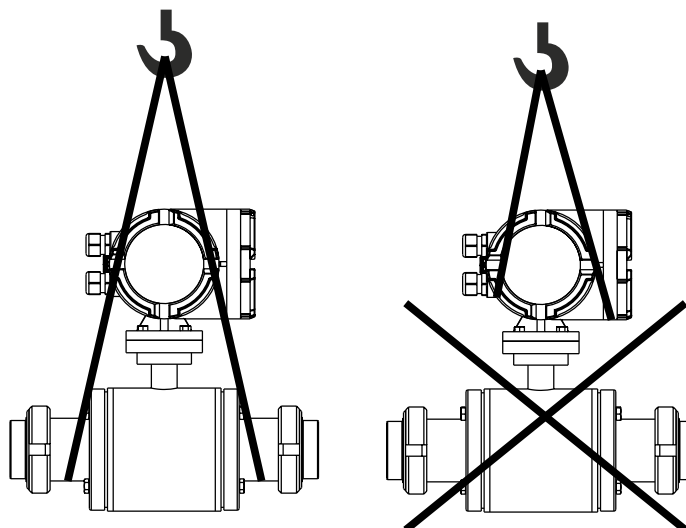

#### 7.4 - INSTALLATION GENERAL CRITERIA

The direction arrow marked on the nameplate is flow direction when calibrated in factory, you should install the flowmeter to make the actual flow direction same as the flow direction arrow marked on the nameplate. If this is not possible, simply reverse the direct flow direction through the “flow direction”

The upstream straight pipe should be longer than 5XDN and the downstream straight pipe should be more than 3XDN in order to guarantee the accuracy of measurement.

#### 7.5 - INSTALLATION IN PIPELINE

Installation may be horizontal or vertical, but make sure no deposit on the electrodes or air bubbles when horizontal installation. See Fig.13-A.

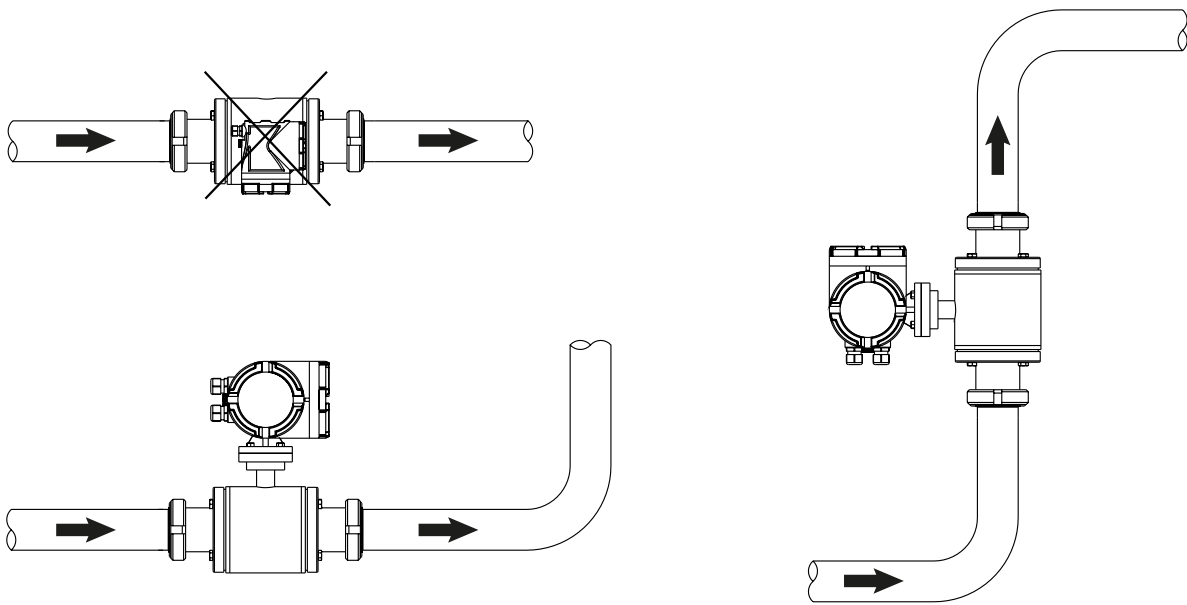

Fig.13-A. Installation in horizontal or vertical pipeline

To install an rectifier or straight pipe is necessary to normalize the flow profile if there are pipe elbow, flow regulation valve or half-open ball valve in front of the sensor. See fig.13-B.

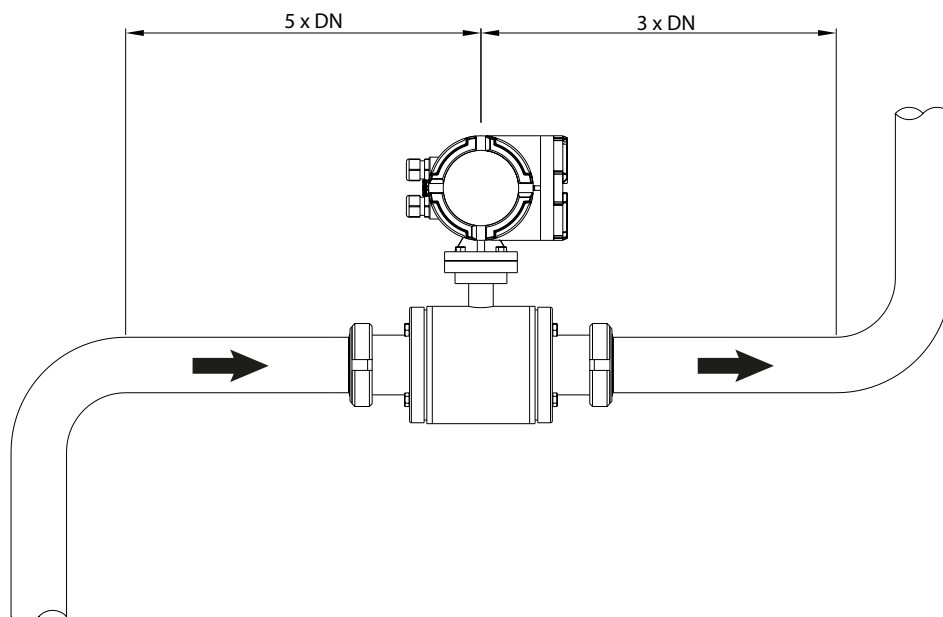
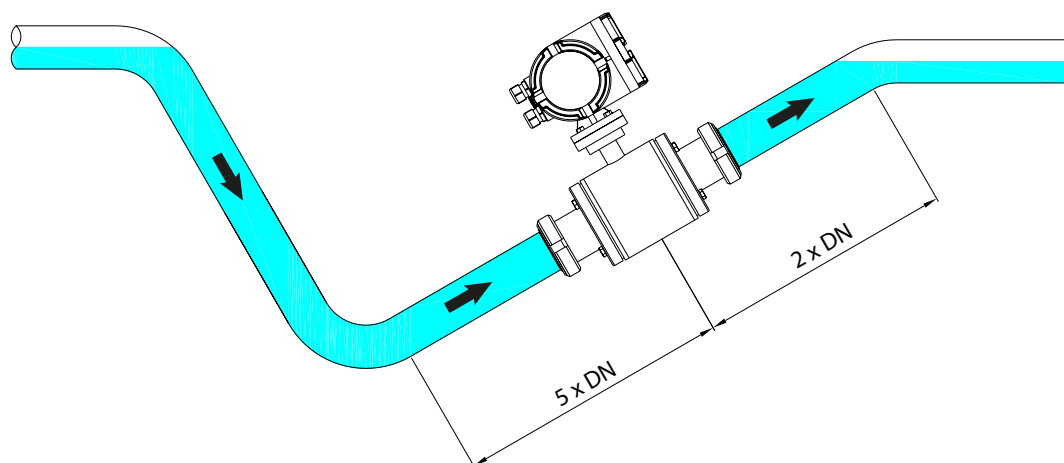

Fig.13-B. Requirement to install the flowmeter straight pipes

The electromagnetic flowmeter must be installed so that the pipe is always completely filled with fluid. In partially filled pipe case, the flowmeter must be installed with the siphon phenomenon, for which the pipe stretch where the meter is installed is kept always full. See **Fig.14-A**.



**Fig.14-A** Installation in partially filled pipes

The electromagnetic flowmeter must not be installed in the pipe section with a free pipe outlet that could run empty. When installing in a downstream pipe, please make sure the pipe is always fully filled with medium. See **Fig.14-B**.

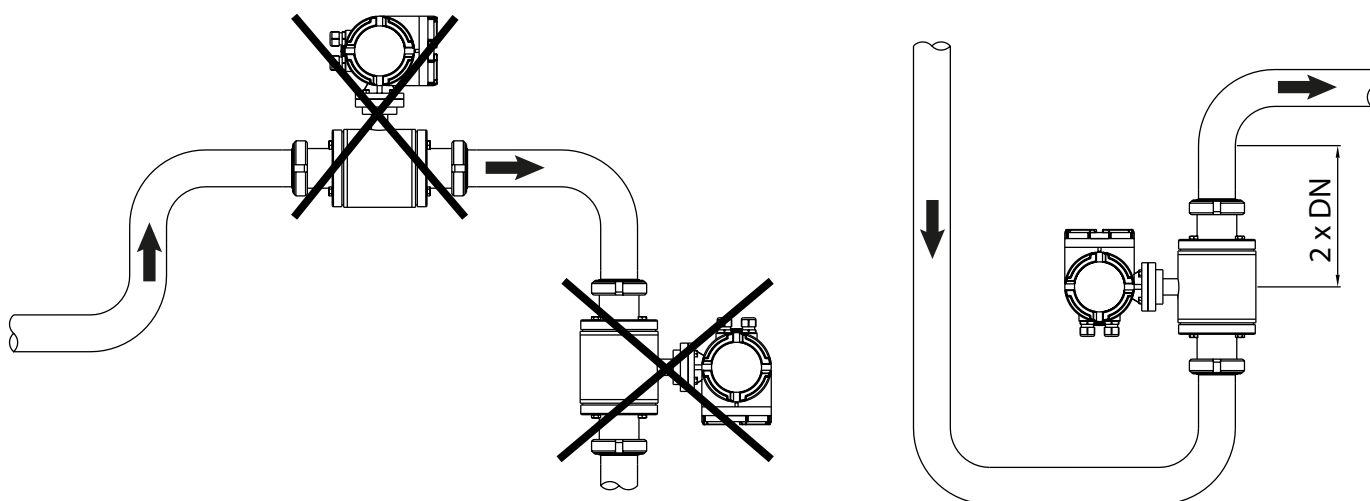

**Fig.14-B** Installation in pipe without emptying

The electromagnetic flowmeter can not be installed at the pipe highest point, because air or gas accumulations may occur in the measuring pipe. See **Fig.15-A**

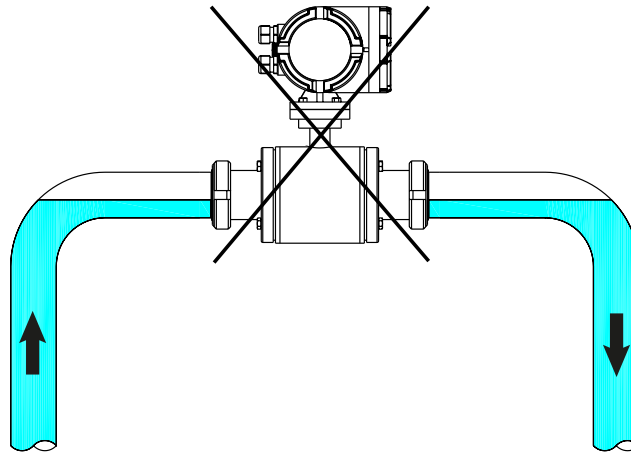

**Fig.15-A** Installation at highest point

The electromagnetic flowmeter can not be installed upstream of a pump to prevent cavitation, which can damage the sensor lining. See **Fig.15-B**

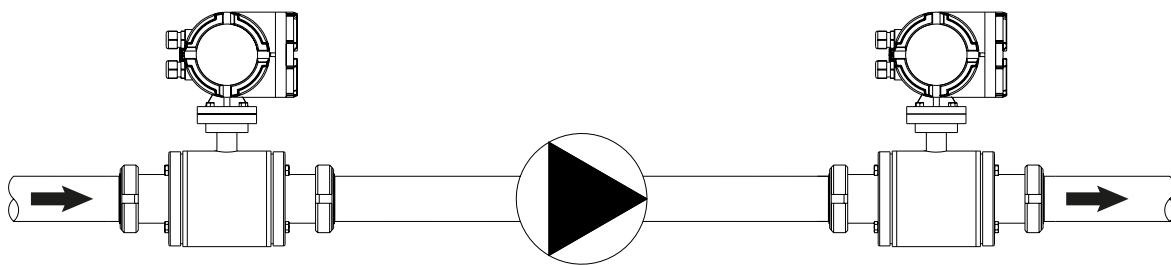

**Fig.15-B** Pump proximity installation

Install a siphon (a) with a vent valve (b) downstream of the sensor in down pipes longer than 5 meters. This precaution is to avoid low pressure and the consequent risk of damage to the lining of the measuring tube. See **Fig.15-C**

**WARNING:** all the phenomena that generate a strong depression inside the pipe can irretrievably damage the insulating coating of the sensor tube itself.

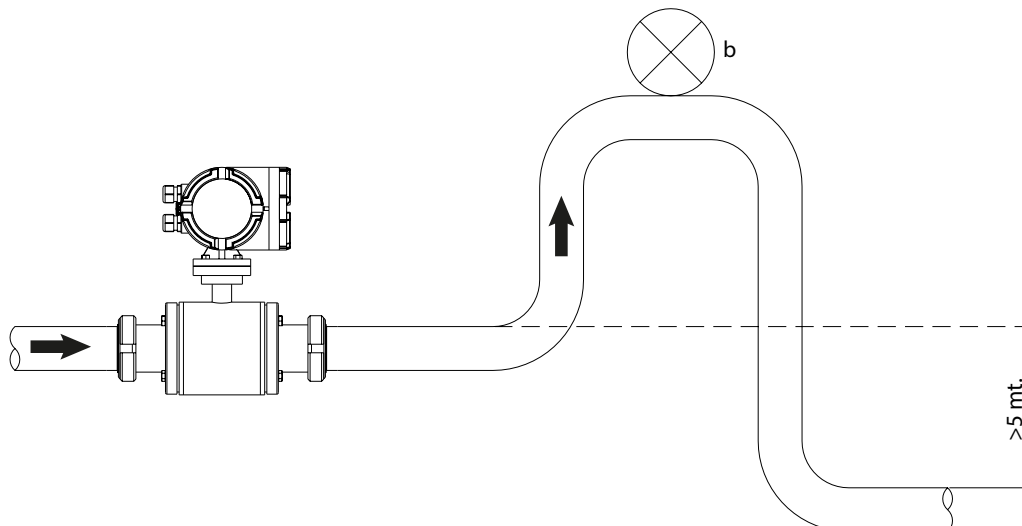

**Fig.15-C** Installation in proximity of a >5m down pipe section

### 7.6 - INSTALLATION PRECAUTIONS

An all-weather cover should be used to prevent the housing from the direct sunlight or rain when the device is outdoors. The flowmeter should be protected from excessive vibrations, large ambient temperature changes and long-time showers. It should be protected from the leakage of the corrosive liquid.

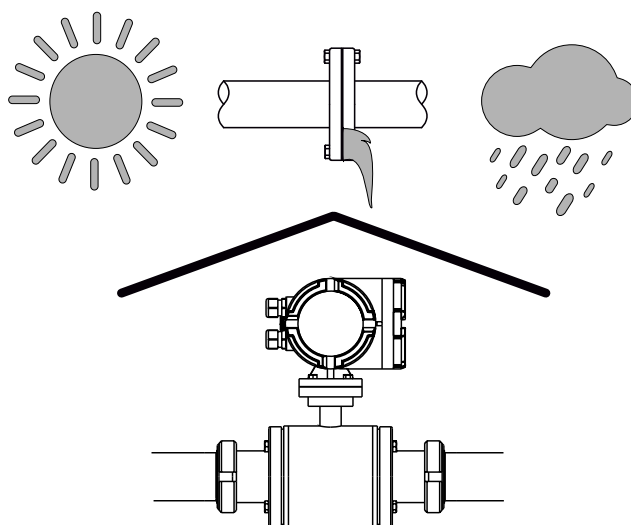

### 7.7 - PIPE CONNECTION

The sensor should be supported by the connecting pipes, it cannot withstand its own weight. Mechanical and thermal stress must be avoided.

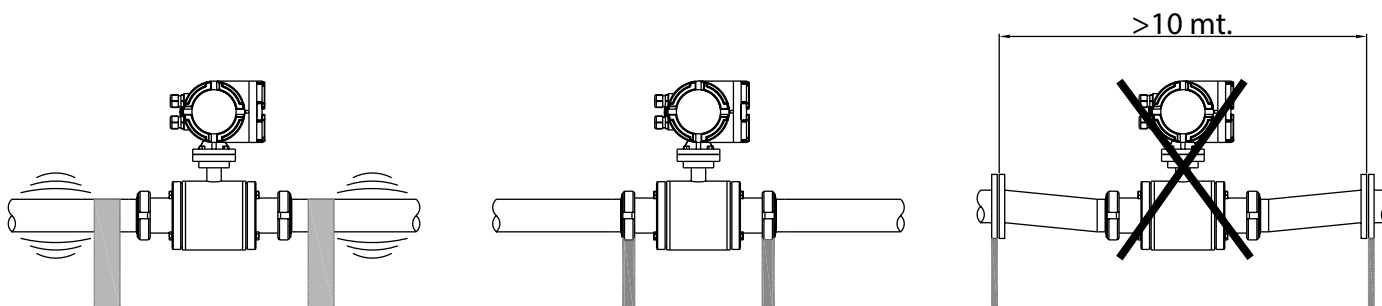

## 7.8 - MOUNTING REQUIREMENTS

- a) The sensor pipe and the line pipes must have the same axis. For the sensors under DN50, the axial difference between the measuring tube and operating pipe should be less than 1.5mm; for the sensors from DN65 to DN300, it should be less than 2mm; for the sensor over DN350, it should be less than 4mm.
- b) The gasket between flanges should have a good corrosive resistance. The gasket must not extend to the pipe inside.
- c) The threads of the fasten bolts and nuts should be in good condition. The bolts should be fastened using torque spanner with certain torque according the size of flange.
- d) It should take separate measure to prevent the lining from heat when weld or flame cutting in the pipe closed to sensor. If the sensor is installed in a well or immersed in water, the connecting box for sensor must be filled and sealed with sealing glue after commissioning.

## 7.9 - EQUIPOTENTIALITY AND ELECTRICAL INTERFERENCE REDUCTION

The measuring circuit assumes the fluid at ground potential, as it is in most of application with conductive pipes.

The sensor is isolated from the fluid because of the lining, therefore it's necessary to connect the grounding cables to the pipe's flanges, as shown in fig. 18.

The resistance for grounding connection should be less than 10ohm.

Most of application do not require special precautions for installation, the only requirement is to keep the signal cable separate from the main cable.

In case of sensor with cathodic protection or electrolysis processes, the main current shall not flow through the measured fluid.

The following measure should be taken in order to reduce the influence of magnetic field:

- a) With conductive pipes, potential equalization is made by connecting sensor and the adjoining pipes as shown in figure.

The bolt connection for flanges can not be used instead of the electric connection, it must have an additional electric connection as shown in **Fig.18**.

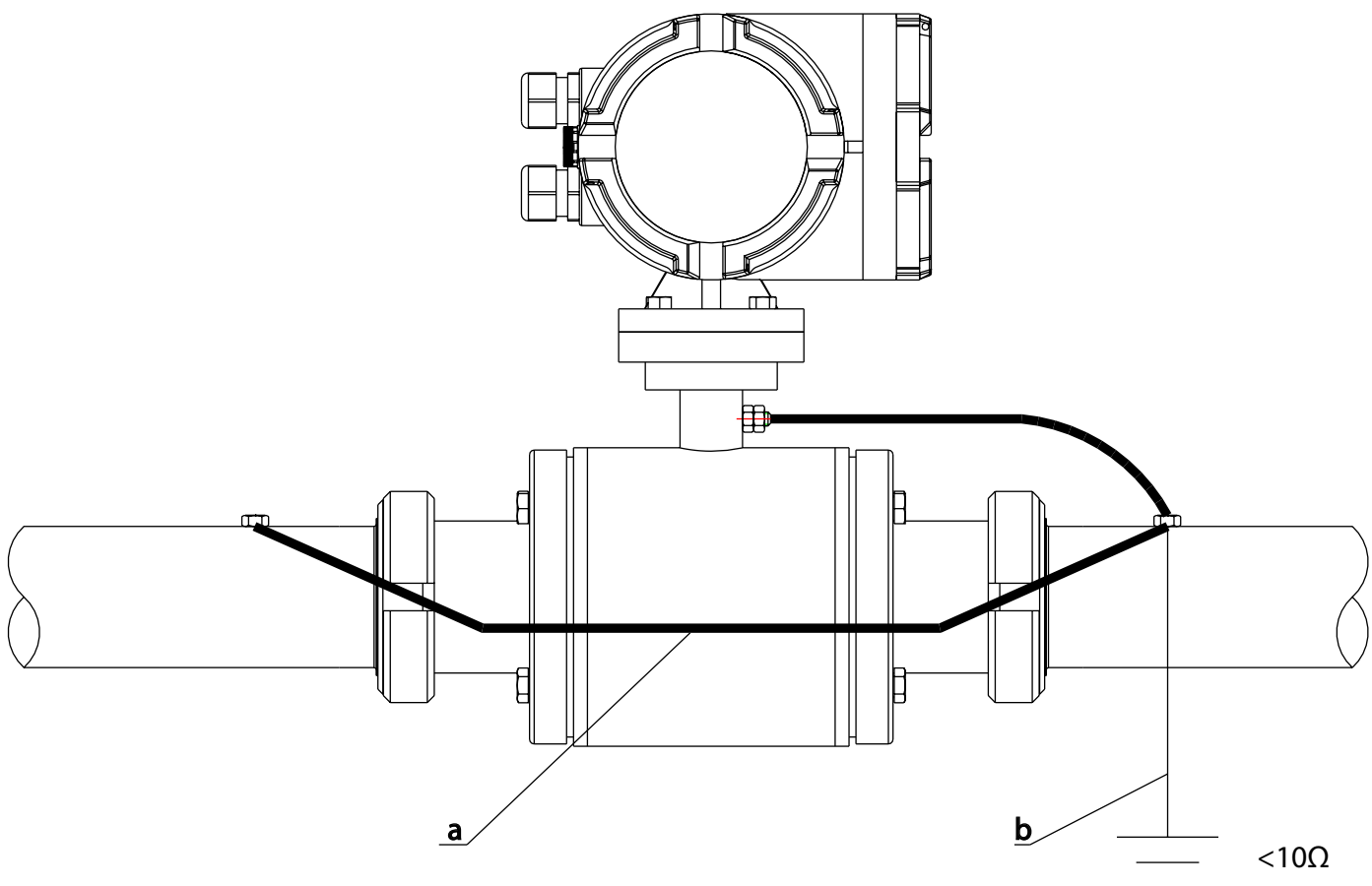

**Fig.18** Sensor equipotentiality



## 7.10 - PREPARATION FOR OPERATION

*Strictly check the instalment and wirings before it gets into operation!*

**It shall be pointed out that the instrument, including the sensor and converter has been fully adjusted, calibrated with actual flow, and inspected under strict measures. All the units are certified. No further adjustments are required when put it into operation. Observing the contents in this manual, to check and analyze any malfunction**

*The following steps are to be followed to get the instrument into operation.*

- 1) Make sure that the sensor is completely filled with fluid.
- 2) Turn the power supply ON. After approx. one minute, the display will show a value which indicates that the wire connection is correct. If the flow value is negative, it can be adjusted via the “flow direction” parameter.
- 3) Zero verification. Shut off the valve tight in downstream first and then the valve in upstream, to let the liquid stops to flow in the pipeline. The displayed value should be 0. The value displayed can be corrected at the converter if the value is different than 0.

## 7.11 - MAINTENANCE

Generally, no extraordinary maintenance is needed on magnetic flowmeter.

Only in case the product can adhere to the inner wall of the sensor, and its electrodes, it is necessary to perform periodic cleaning operations.

***Be careful not to damage the lining and the electrodes.***

## 8-ELECTRICAL CONNECTIONS

### 8.1 - CABLE ENTRY

The compact version converter enclosure has n. 2 M20x1.5 cable glands.

The converter enclosure remote version has n.2 M20x1.5 cable glands for power supply and outputs signal, and 2 M16x1.5 cable glands for sensor pipe connection

### 8.2 - ELECTRICAL CONNECTION REQUIREMENTS

Before making the electrical connections, consider the following standards and be sure to have the correct power supply, ducts and other accessories.

#### 8.2.1 - Power supply voltage

Rsmag transmitter is designed to be powered with  $85 \div 265\text{Vac}$  (50 to 60 Hz),  $24\text{Vac/dc}$ ,  $12\text{Vdc}$  voltage.

#### 8.2.2 - Power supply voltage interruption

Power supply wires must be connected to the device via a circuit breaker or an external disconnecting switch.

The switch or circuit breaker should be clearly labeled and located close to the transmitter.

#### 8.2.3 - Infiltration and humidity prevention

To avoid the humidity infiltration inside the converter and sensor pipe is recommended:

- fully well tighten the cap and the cable glands .
- position the cable so that it forms a downward curve at the M20x1.5 and/or M16x1.5 output (see below figure); in this way the condensation and/or rain water will tend to drip from the curve bottom.

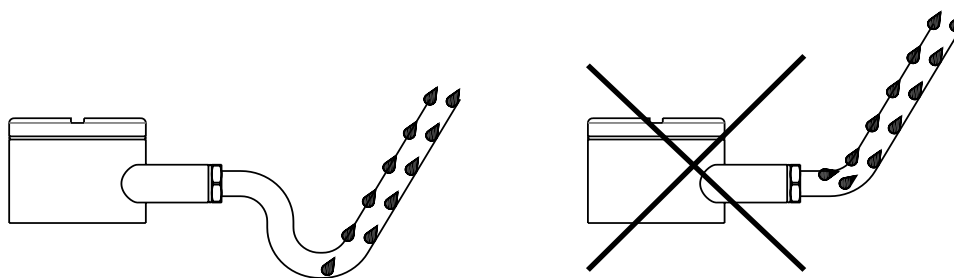

### 8.3 - POWER CONNECTION

To connect the power supply to the meter, complete the following steps:

- 1) Open the box connections cover.
- 2) Insert the power supply cable through the cable gland.
- 3) Follow the sequent list to connect the power supply cable:

#### AC Units:

- Connect the GND grounding terminal  $\perp$
- Connect the wire to terminal **N**.
- Connect the phase to terminal **L**.

#### DC Units:

- Connect the GND grounding terminal  $\perp$
- Connect + 24Vdc or 12Vdc to terminal **L (+)**.
- Connect 0V to terminal **N (-)**.

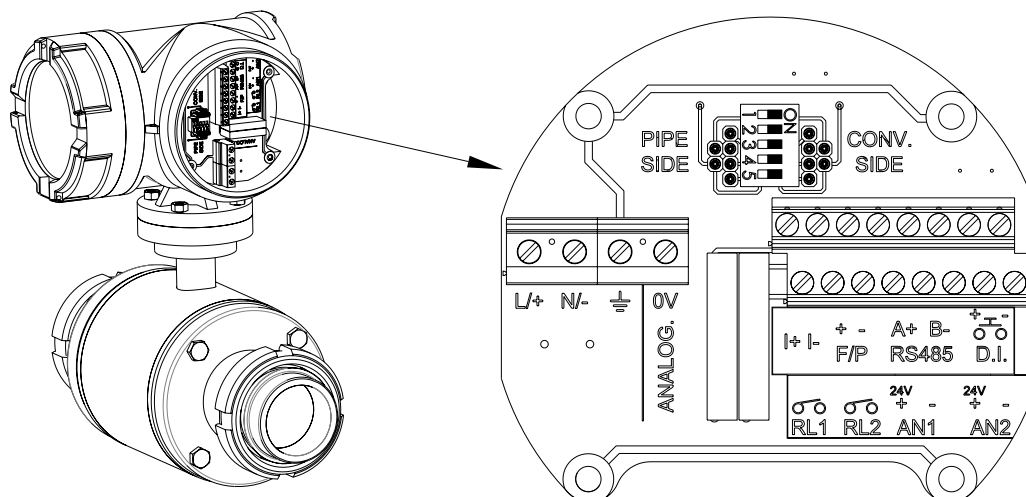

### 8.4 - Dip-Switch configuration

For the Rsmag flowmeter proper operation, the dip-switch relative to the interface connection to the external diagnostic unit must be set to “ON” as shown in the following drawing

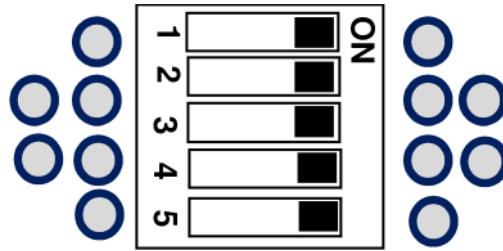

### 8.5 - OUTPUT

To connect the analog and/or impulsive output follow the instructions of the following points.

#### 8.5.1 - Analog output

- The current output is powered from the transmitter.
- The circuit resistance must be equal to or less than 500ohm.
- Follow the below steps to connect the signal cable to the transmitter:
  - 1) Insert the signal cable through the cable gland.
  - 2) Connect the two wires to I+ and I- terminals.

The below drawing shows the connection diagram between the Rsmag flowmeter and SLM2XH3 flow totalizer unit.

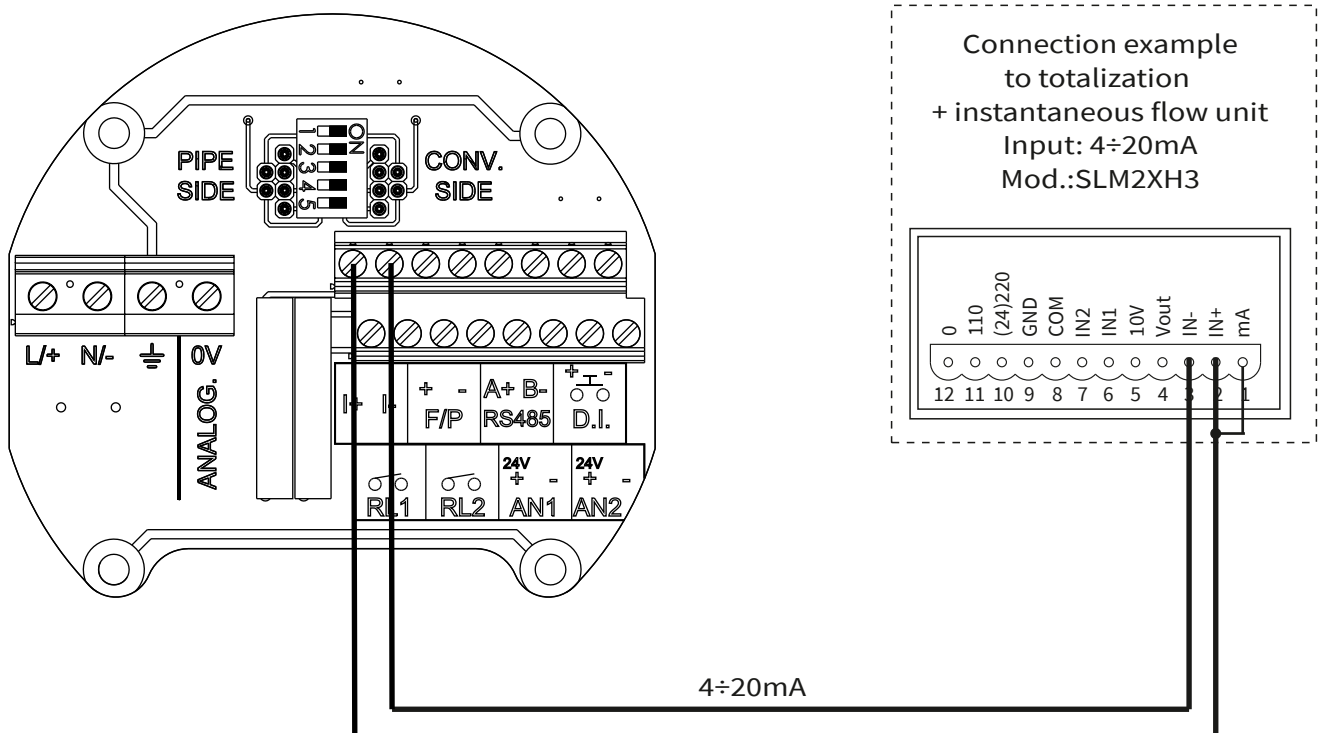

### 8.5.2 - Digital output

When digital output is set in frequency mode, it generates an 0.1÷10000Hz output signal proportional to the measured flow rate; however if it's set in pulsed mode generates an output signal in relation to the totalized volume increase. The signal is normally used in combination with an external totalizer, a pulse counter or an acquisition system. The resistance in the circuit must be equal to or greater than 100Kohms.

Follow the below steps to connect the signal cable to the transmitter:

- 1) Insert signal cable through the cable gland.
- 2) Connect two wires to F/P+ and F/P- terminals

N.B. - When the Rsmag pulse output is connected to an acquisition system that requires a current higher than 11mA, a properly sized pull-up resistor must be connected to ensure the minimum current required by the acquisition system connected (see drawing below); example: if the acquisition system requires a min. current of 15mA, a 1,6 Kohm pull-up resistor must be connected (according to the calculation  $R = V / I = 24V / 15mA = 1,6Kohm$ ) between an external power supply of 24 Vdc and the acquisition system input terminal.

The below drawing shows the connection diagram between the Rsmag flowmeter and the 199-B1X counter unit.

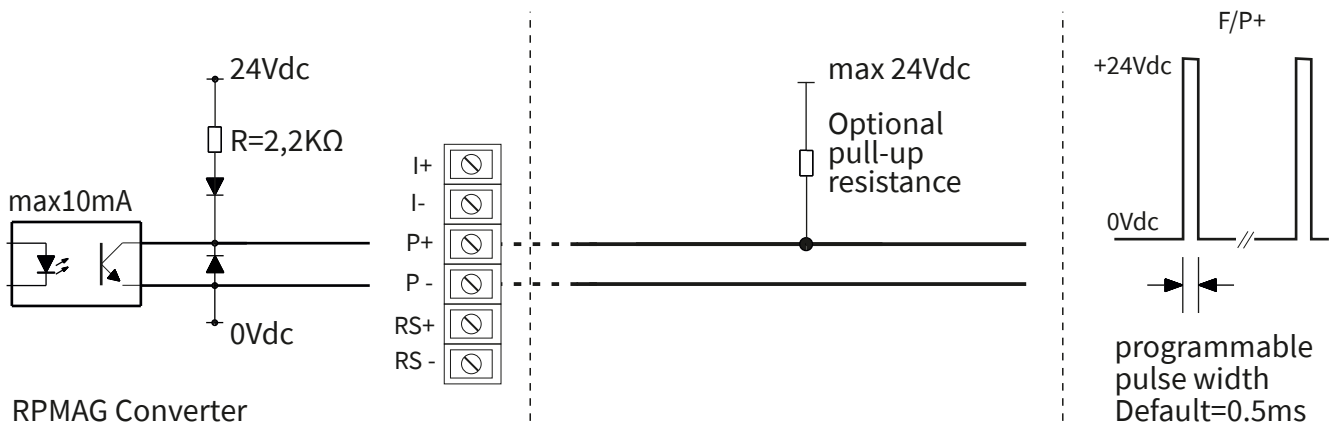
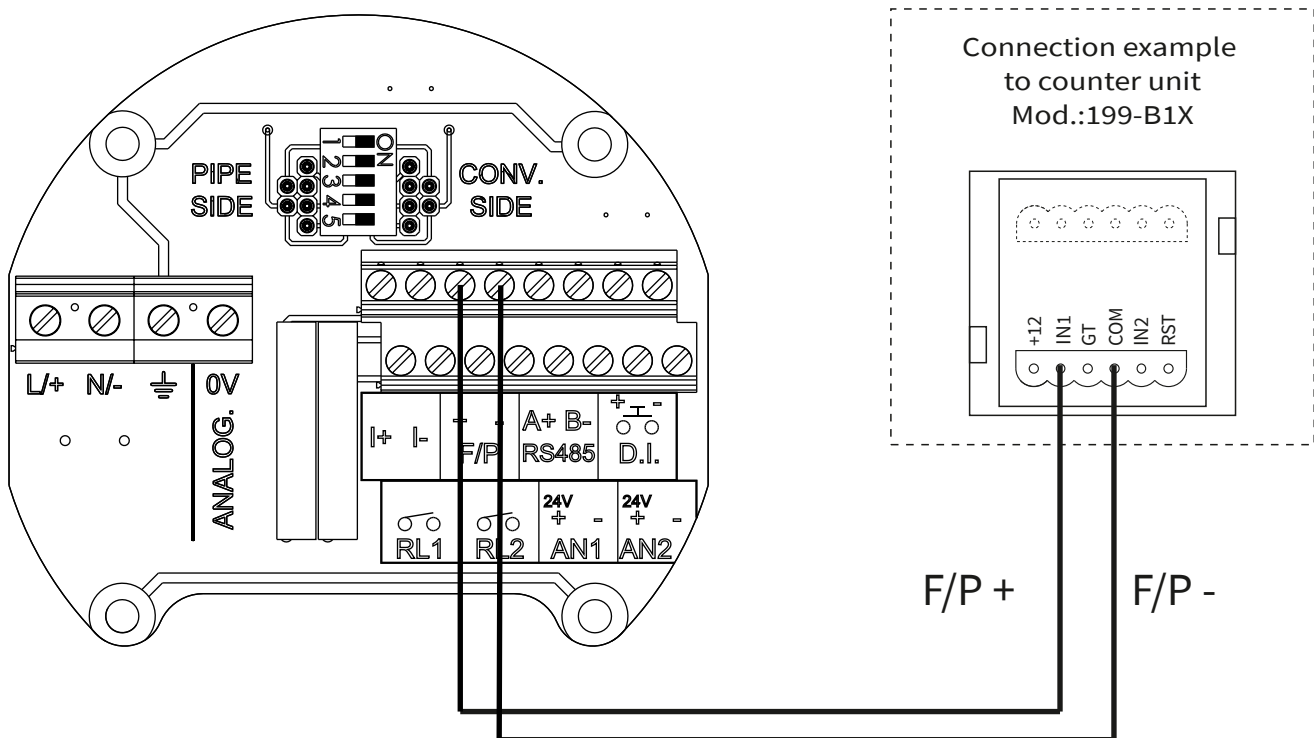

### 8.5.3 - Alarm output

Follow the below steps to connect the signal cable to the transmitter:

- 1) Insert the signal cable through cable gland.
- 2) Connect two wires to **RL1**, for the #1 alarm threshold, and **RL2** terminals for #2 alarm threshold.

The below drawing shows the connection diagram between the Rsmag flowmeter and the 199-B2X multifunction counter unit.

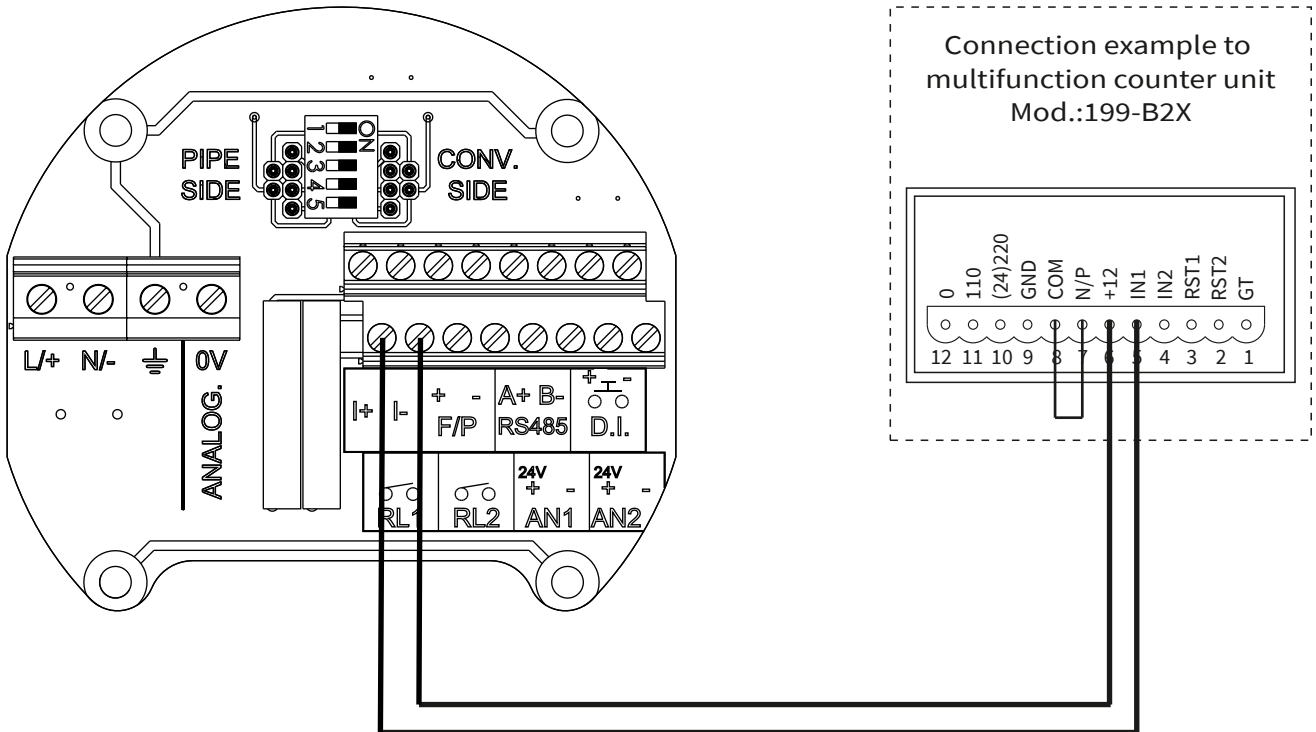

### 8.5.4 - RS485 serial output

Communicate via MODBUS RTU is possible in models with RS485 serial port. Connect the serial cable to **A+** and **B-** terminals.

The below drawing shows connection example diagram between Rsmag flowmeter and a PC.

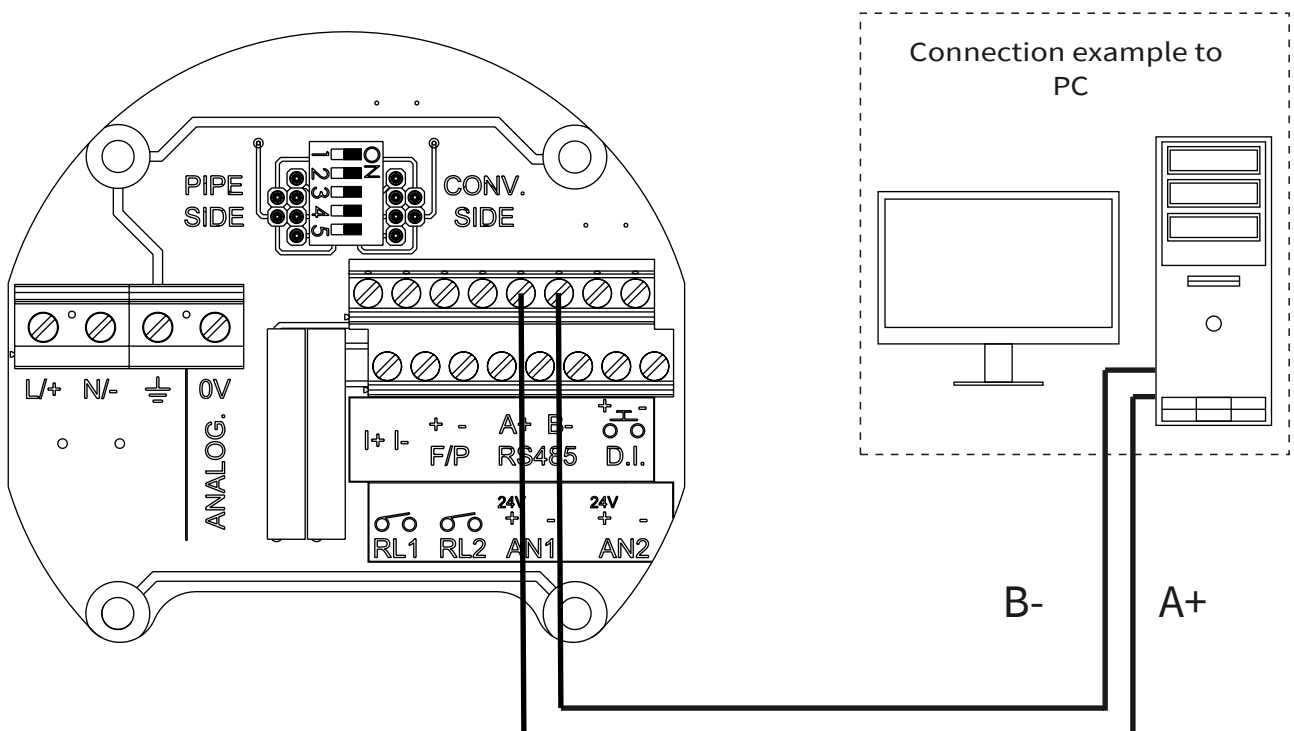

## 8.6 - INPUTS

### 8.6.1 - AN1 and AN2 analog inputs

- The two analogue current inputs have a 100ohm input impedance.  
 To connect the signal cable to the transmitter, follow the steps below:
- 1) Insert the signal cable through the cable gland.
  - 2) Connect the two wires to AN1 + and AN1- (or AN2 + and AN2-)

In the drawing below it shows the wiring diagram of the flow meter “Rsmag” and the pressure transmitter “KPT”.

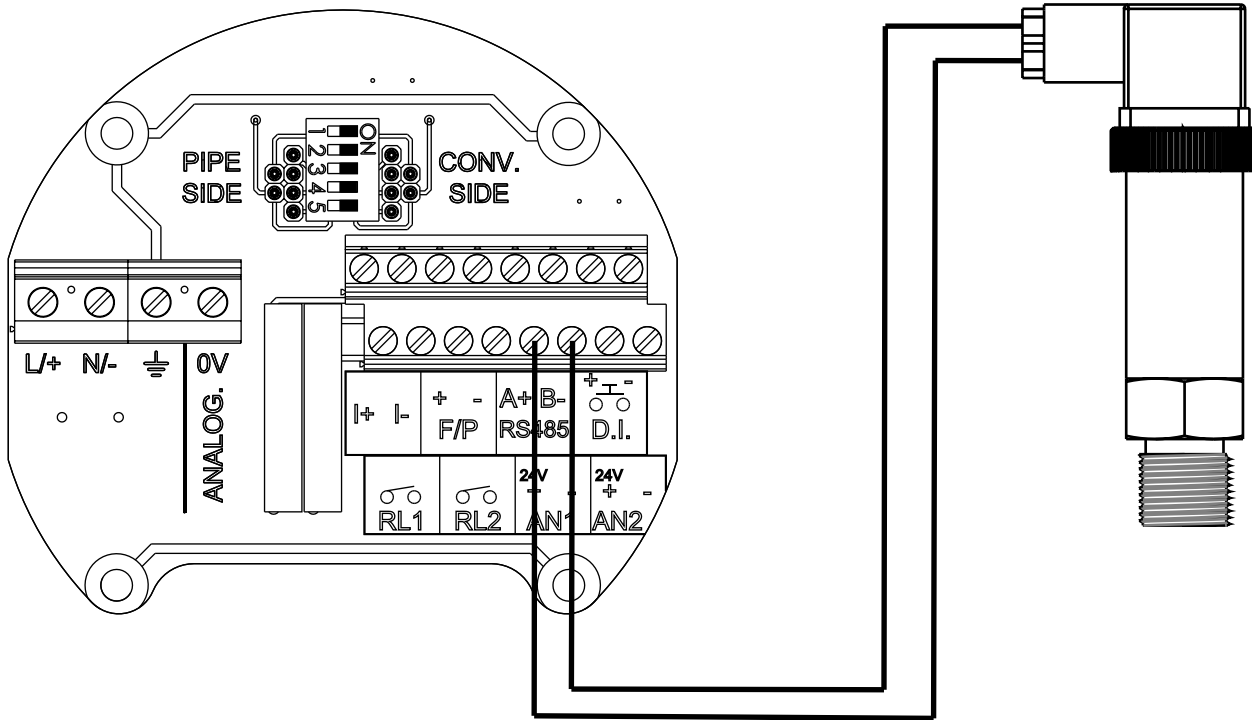

### 8.6.2 D.I. - digital input

The “D.I.” optically isolated digital input can be driven by a normally open contact, with a minimum voltage of 10Vdc up to a maximum of 26Vdc.  
 Closing the contact as “DI” terminals, the batch counter will be reset and the RL1 output will again be energized with closed contact.  
 N.B. - The batch counter can be reset only when its value is equal or greater than the threshold set (see “BATCH” parameter).  
 Activating the partial totalizer function (PARTIAL TOT), it is possible, closing the contact, in order: start, stop and reset the counting.

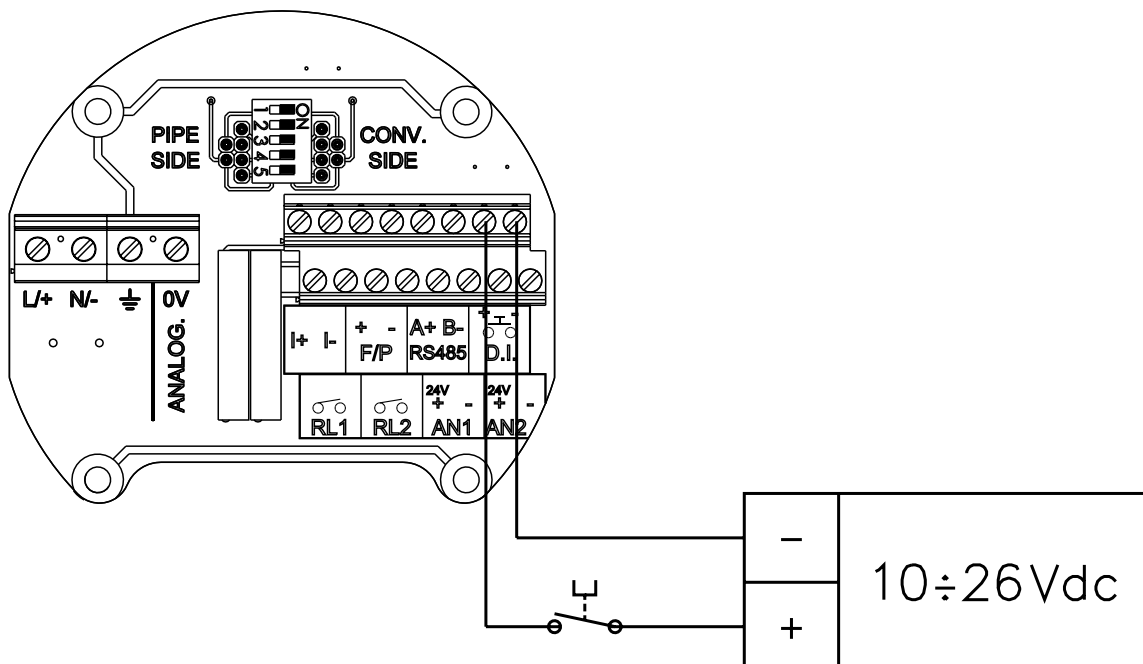

### 8.7- REMOTE VERSION

During the remote version installation comply with the following information to ensure correct measurements:

- 1) The cables must be as short as possible, especially with low conductivity fluids.
- 2) The cables should be far from electrical machinery and switching devices such as contactors or solenoid valves.
- 3) The cables must not be in conduit with power cables or cables for the switching devices control.
- 4) When necessary, ensure the equipotential between sensor and transmitter.
- 5) The maximum cable length is a fluid conductivity function. Refer to paragraph 8.7.2.

Connect the sensor to the converter according to the below diagram.

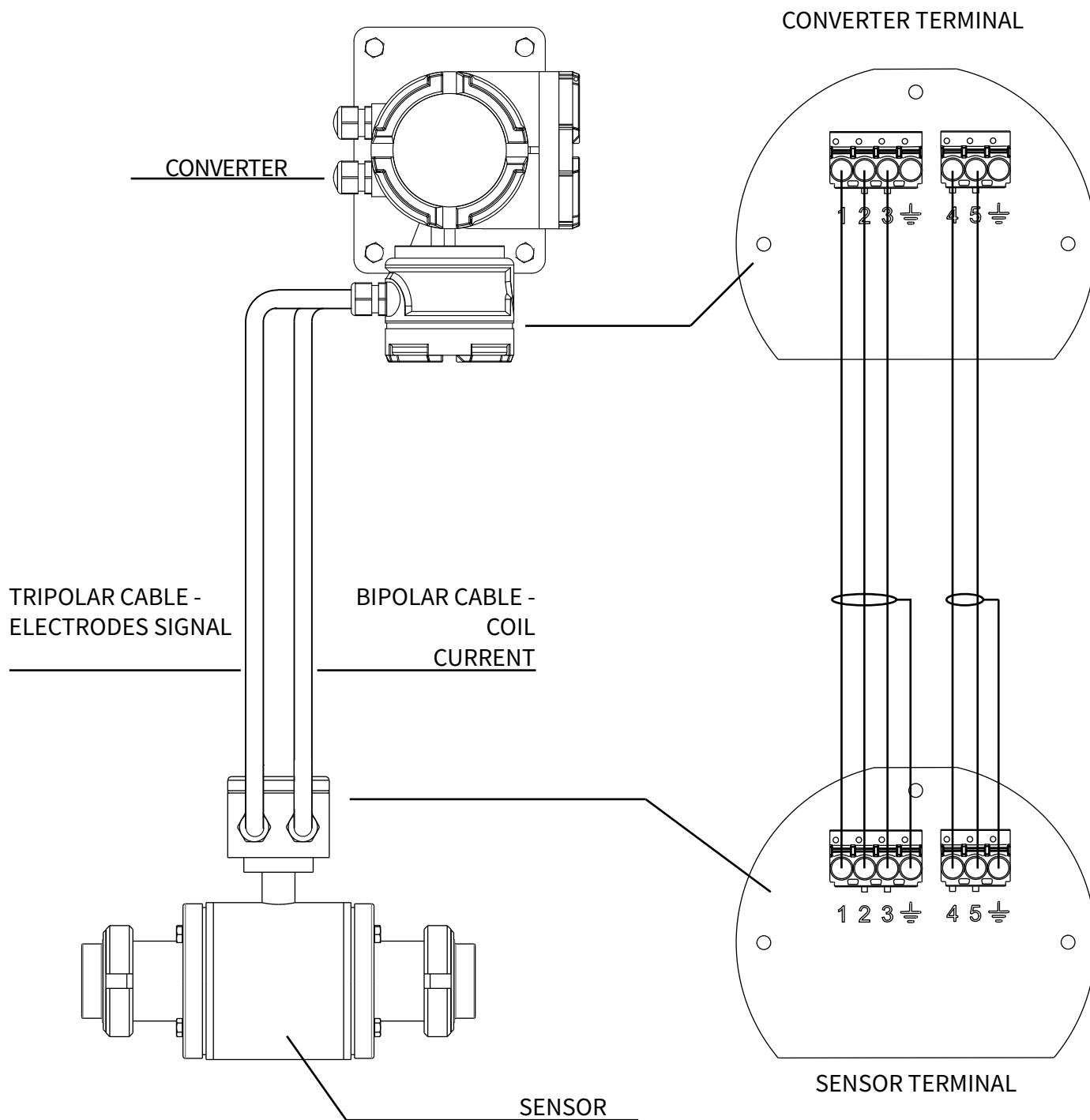

### 8.7.1 - Remote version wiring

Cable	Wire		Function	Terminal position
	Num.	Color		
Bipolar	4	black	coil	4
	5	brown	coil	5
	braid		shield	$\perp$
Tripolar	1	white	electrode 1	1
	2	yell./green	common GND	2
	3	brown	electrode 2	3
	braid		shield	$\perp$

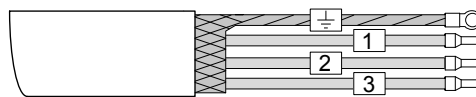

SHIELDED TRIPOLAR CABLE

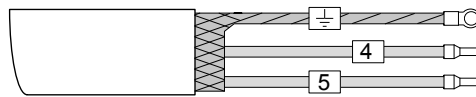

SHIELDED BIPOLAR CABLE

### 8.7.2 - Connecting cables length

Maximum length of the connecting cables between the sensor and the convertor is determined by the fluid conductivity value.

In the graph below the gray highlighted area indicates the allowed cable length in relation to the fluid conductivity value. With an 150 microS fluid conductivity, for example, the connection cables will have a maximum length of 150 meters.

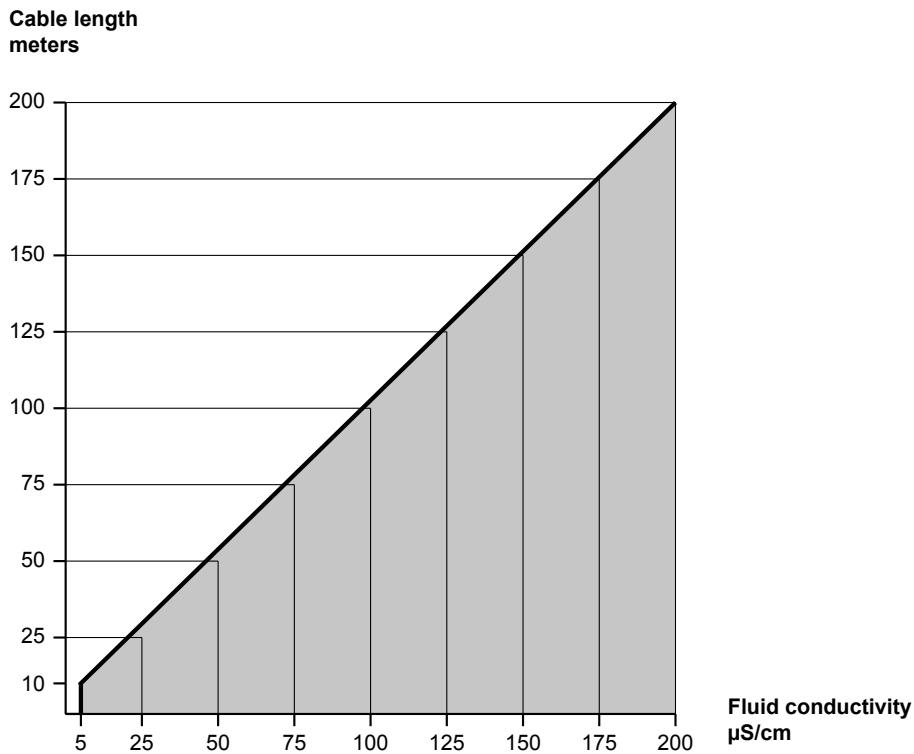



### 8.7.3 - Connecting cables

#### 8.7.3.1 - Coil cable technical specification

Shielded bipolar cable FR20H2R 2x1.5 section	
Conductors	Tinned copper stranded wire, class 5
Insulations	PVC R2 Ø 2,8mm ± 0,1
Conductors Colors	Black - Brown
Cable stranding	Concentric with polyester tape
Shielding	Tinned copper braid
Sheath	PVC RZ resistant to hydrocarbons; Ø 8,2mm ± 0,30; RAL5015 blue color
Marking	SGM-LEKTRA RODANO MILANO ITALY - 525B005A
Operating temperature	-25÷+70°C (fixed installation)
Test voltage	3KV V.c.a.
Working voltage	450/750V
Conductors electrical resistance	CEI 20-29
Reference Standards	CEI 20-22 II-IEC 332.3A-ROHS 2011/65/UE(ROHS 2)

#### 8.7.3.2 - Electrodes signal cable technical specification

Shielded tripolar cable FR20H2R 3x1.5 section	
Conductors	Tinned copper stranded wire, class 5
Insulations	PVC R2 Ø 2,8mm ± 0,1
Conductors Colors	White - Brown - Yellow/Green
Cable stranding	Concentric with polyester tape
Shielding	Tinned copper braid
Sheath	PVC RZ resistant to hydrocarbons; Ø 8,2mm ± 0,30; RAL5015 blue color
Marking	SGM-LEKTRA RODANO MILANO ITALY - 525B005A
Operating temperature	-25÷+70°C (fixed installation)
Test voltage	3KV V.c.a.
Working voltage	450/750V
Conductors electrical resistance	CEI 20-29
Reference Standards	CEI 20-22 II-IEC 332.3A-ROHS 2011/65/UE(ROHS 2)

## 9-LOCAL OPERATOR INTERFACE (LOI)

LOI is an operator communications center for the Rsmag. Through the LOI, the operator can access any transmitter function for changing configuration parameter settings, checking totalized values, or other functions.

### 9.1 - SAFETY MESSAGES

Instructions and procedures in this section may require special precautions to ensure the safety of the personnel performing the operations. Information that raises potential safety issues is indicated by a warning symbol. Please refer to the following safety messages before performing an operation preceded by this symbol: 

### 9.2 - WARNINGS

#### Explosions could result in death or serious injury

- Verify that the area of installation and operation comply with the characteristics of the measuring tube and the transmitter.
- Make sure only qualified personnel perform the installation.
- Do not perform any service other than those contained in this manual unless qualified.









#### High voltage that may be present on leads could cause electrical shock

- Avoid contact with leads and terminals.





### 9.3 - LOI Features

The LOI has the VL701 program module has 4 buttons which allow to perform all operational, control and programming instrument functions.

In the configuration menus, is possible:

1. Submenus and parameters access; press  to select and press  to access.
2. Parameter options choice: press  to select the option and press  to store the option.  
Press  to exit without saving.
3. Configure the parameter values; in some parameters the configuration is done by setting a value (eg, in the MAX FLOW parameter is possible to change the number):  
press  to select the digit to be modified (the digit is highlighted in inverse), press  to change the highlighted digits number, press  save the set value and exit automatically.  
Press  to exit without saving.



-  • Exit configuration  
• Back to previous menu
-  • Parameters values modification
-  • Scroll cursor (to the right)  
• Scroll parameters
-  • Configuration access  
• Options confirmation  
• Parameters values confirmation

### 9.4 - VL701 DISPLAY MODULE

The VL701 programming module can be mounted and removed from the Rsmag without affecting the unit operation. Unscrewing the cover, the VL701 module can be mounted (by clockwise rotation until it clicks) or dismantled (by rotation counterclockwise) as shown in figure.

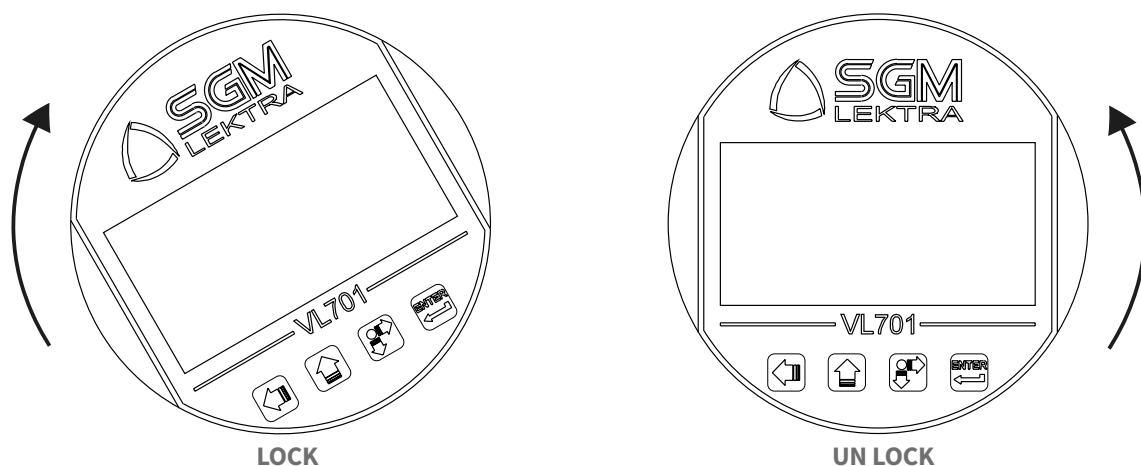

### 9.5 - DISPLAY ROTATION

If it is necessary the display can be rotated, as indicated in the following procedure:

1.  Disconnect power supply from transmitter.
2. Unscrew the transparent cover.
3. Remove the two screws that secure the “display/electronics” bracket to the container, paying attention to the wiring between the electronics and the terminal.
4. Rotate the display / electronics bracket to set the position (minimum 90° rotation).
5. Tighten the two screws that secure the “display/electronics” bracket to the container.
6. Tighten the transparent cover.

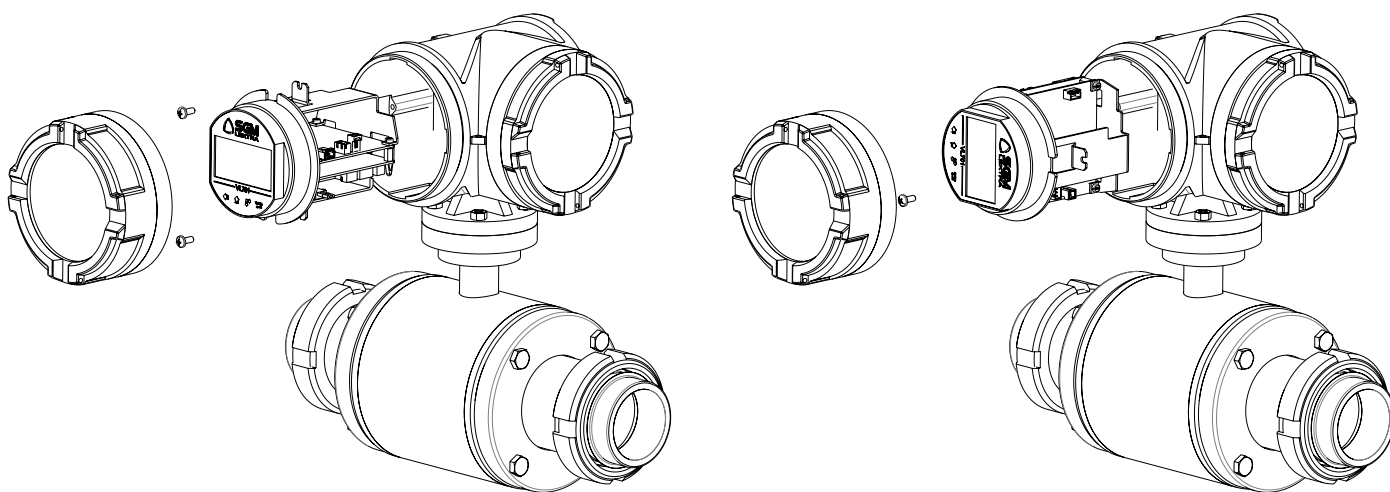

### 9.6 - DATA LOGGER USB PORT (OPT.)

To access the USB port it is necessary to dismount the VL701 module display (see par. 9.4).  
The USB port is used to connect the pen drive, necessary for the internal data logger functioning.

In a new flow meter the Pen Drive is not inserted into the USB port, but is housed behind the display.  
If you do not use the datalogger function, it is advisable not to connect the USB per drive to reduce energy consumption.

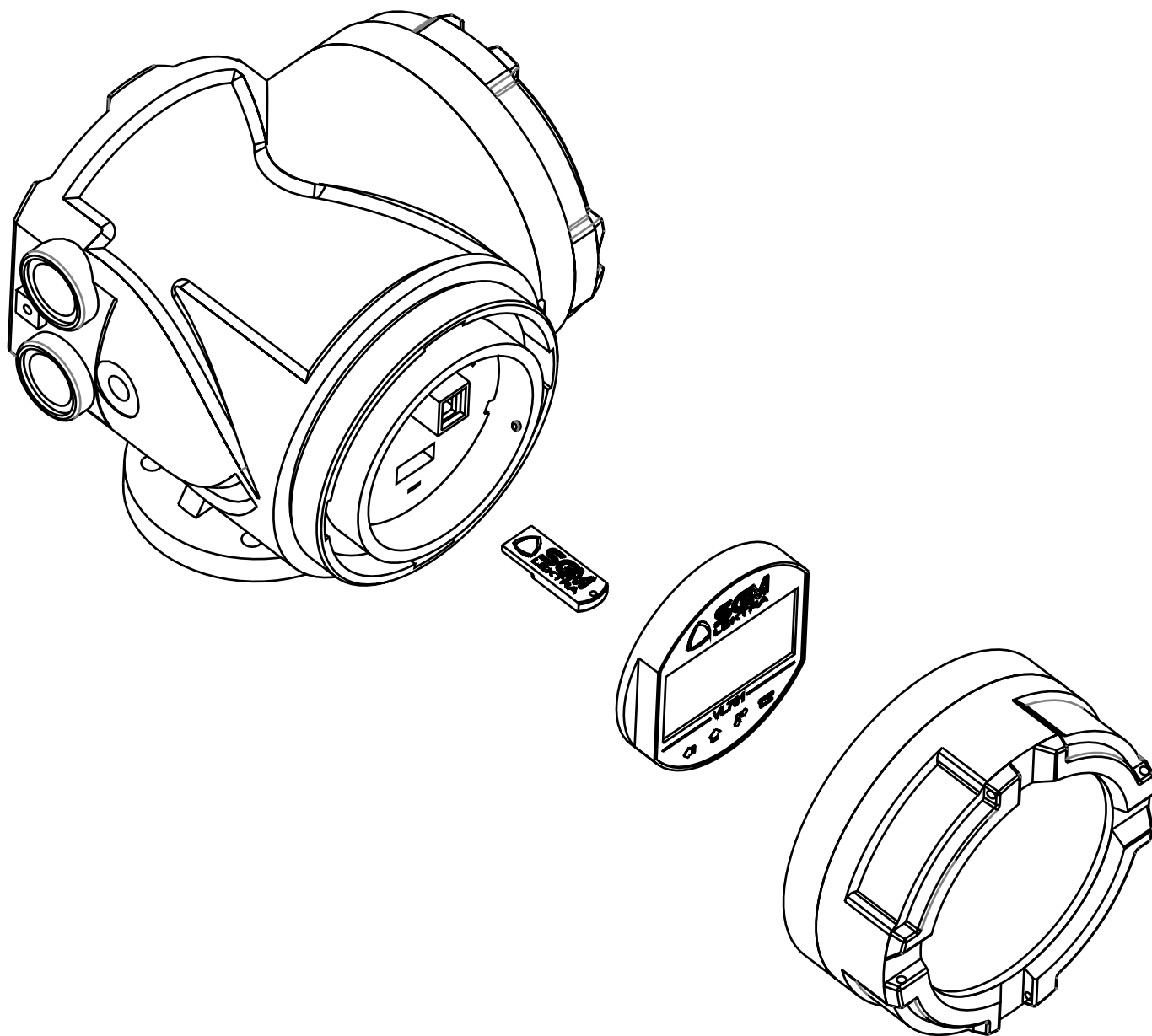

### 9.7 - CONVERTER ROTATION

To a greater functionality and adaptation to the application the entire converter, in addition to the display, can be rotated. By following the below steps:

1. ⚠ Disconnect the power supply voltage.
2. Remove the four screws that secure the converter to the sensor pipe.
3. Slightly lift the converter paying attention to the electrical connections between the sensor pipe and the terminal.
4. Turn the converter (minimum 90° rotation) bringing it to the desired position.
5. Fix the converter to the sensor with the 4 fixing screws.

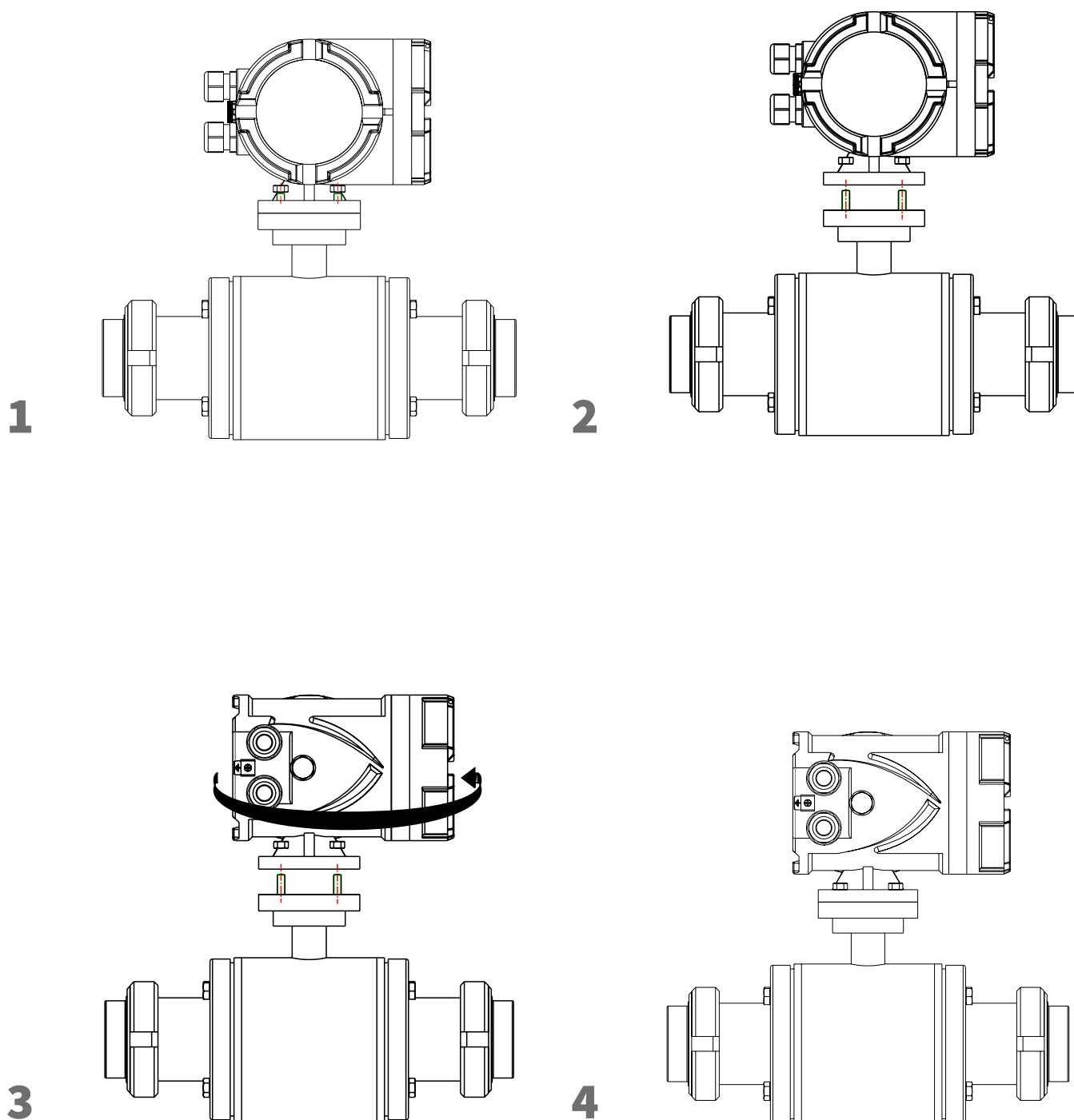

# 10-PROGRAMMING

## 10.1 - DATA ENTRY

The LOI keypad has no numerical keys.

Enter numerical data using the following procedure:

1. Access the appropriate function.
2. Use SCROLL to highlight the digit you want to enter or change.
3. For numerical data, UP ARROW scrolls the digits from 0 to 9  
(UP ARROW or SCROLL are also used to toggle pre-determined choices that do not require data entry).
4. Use SCROLL to highlight and change other digits you want to change.
5. Push ENTER to confirm data entry.

## 10.2 - KEYBOARD LOCK

Simultaneously pressing the LEFT ARROW and SCROLL keys from RUN mode, for 5 seconds, keyboard will be locked. Display will show PADLOCK simbol.

Simultaneously pressing the LEFT ARROW and SCROLL keys from RUN mode, for 5 seconds, keyboard will be un-locked.

## 10.3 - DISPLAY PAGES

The Rsmag, in RUN mode, has six pages to display data and status, press UP ARROW or SCROLL to change page.

### 10.3.1 - MAIN PAGE

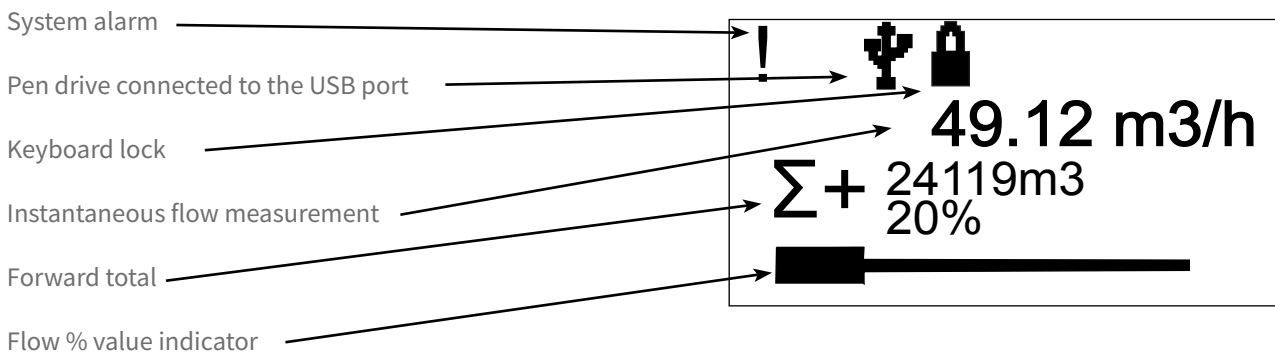

### 10.3.2 - SECOND PAGE

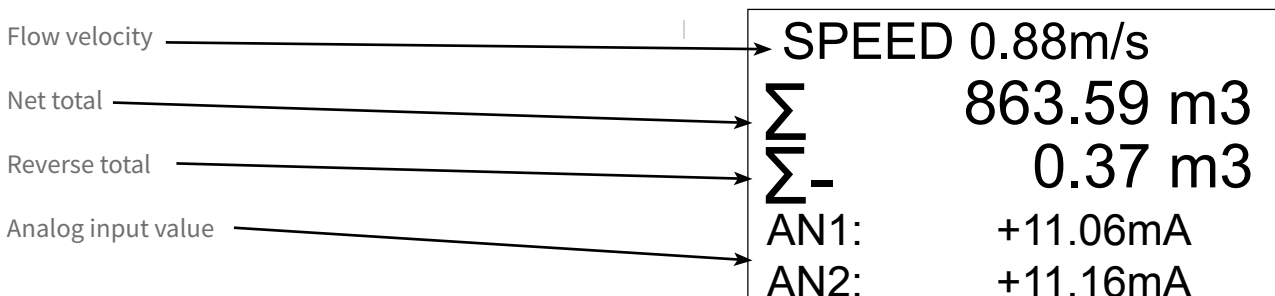

10.3.3 - ALARMS PAGE

The symbol “!” will be displayed when there are system alarms.  
Press SCROLL to access the alarms page.

Press SCROLL again to return to the main page (MAIN)  
Press ENTER to clear the error history (CLEAN)

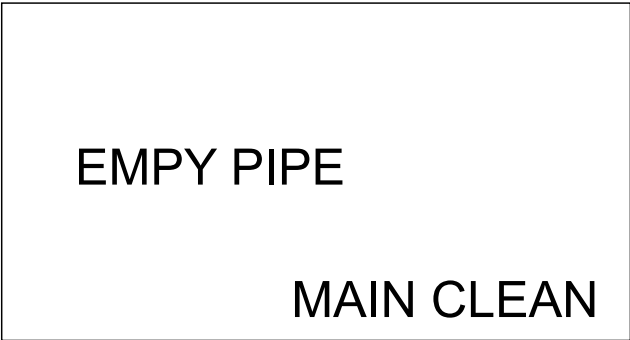

10.3.4 - BATCH PAGE

Preset value  
Increase in the batch partial counter  
Relay output status (closed contact)  
Instantaneous flow rate indicator

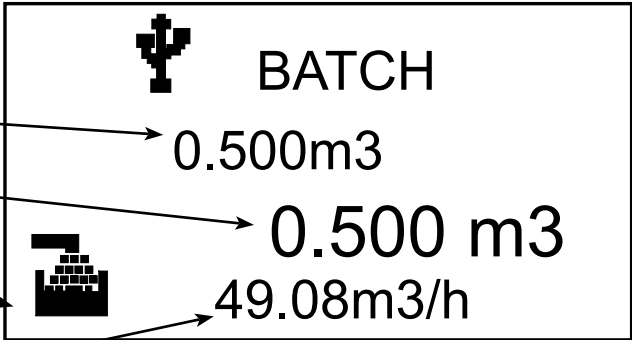

Preset value  
The increase value of batch partial counter is highlighted when it reaches the preset value  
Relay output status (open contact)  
Instantaneous flow rate indicator

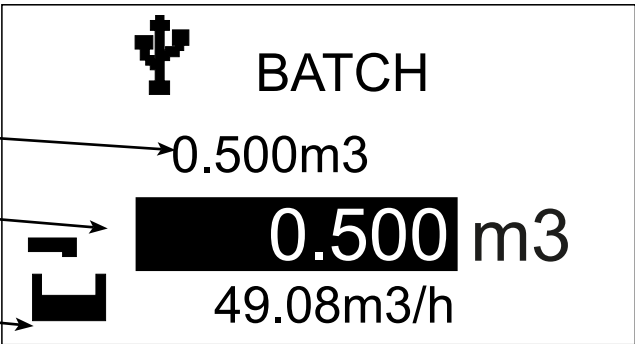

10.3.5 - PARTIAL TOTALIZER PAGE

Increase in the partial totalizer.  
Press START to begin the totalization:  
STOP to arrest  
RESET to reset the totalizer

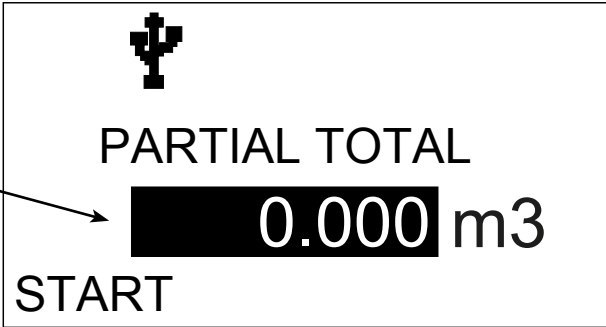

10.3.6 - INFO PAGE

- Instrument serial number
- Event counter of the sensor fundamental parameters
- Pipe diameter (DN)
- Current Firmware revision
- Configuration index of the product
- Q3/Q1 ratio
- Sensor K

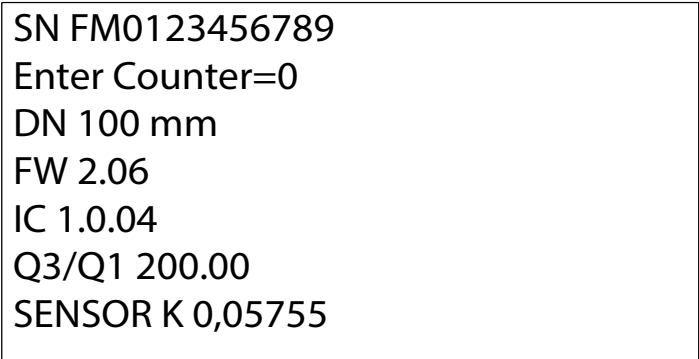

### 10.4 - LOI MENÙ

Press ENTER key from run mode: display will show the list of configuration menu as shown here next.

Press UP ARROW or SCROLL keys to select the desired menu, then press ENTER key to access.

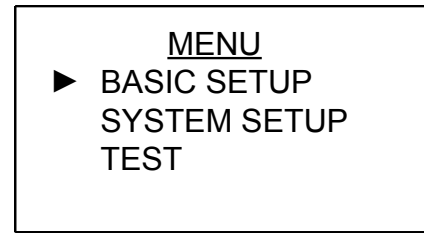

#### 10.4.1 - BASIC SETUP menu

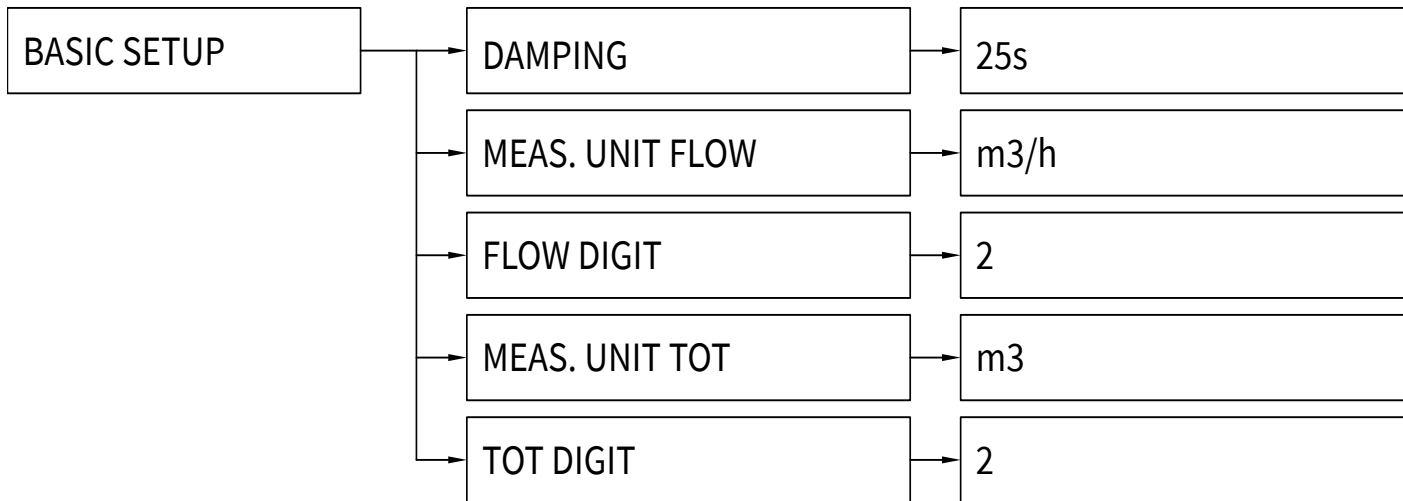

#### 10.4.2 - BASIC CONFIGURATION (BASE SETUP)

Press ENTER key from run mode, the display will be as shown here next, then press ENTER to enter in “BASIC SETUP” menu.

Prss UP ARROW or SCROLL keys to select the desired function and press ENTER key to access.

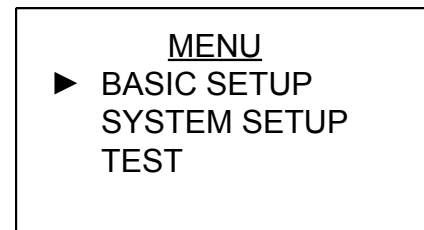

##### 10.4.2.1 -DAMPING

It sets the integration time for measurement.  
Lower values mean fast response, higher values are suggested for reduction of fluctuations in flow measurement.  
Default: 25s;  
Range: 1÷100s

Press ENTER key, the display will be as shown here next.  
With UP ARROW or SCROLL select the option.

Press ENTER to confirm.

The ☺ to confirm the parameter edit storage.

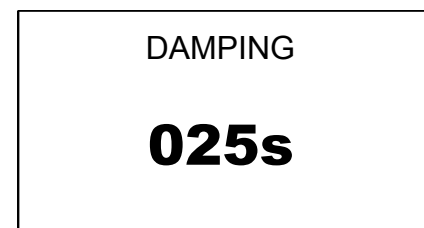
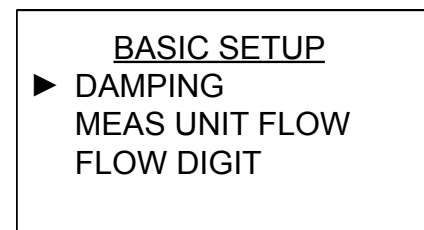



**10.4.2.2 - MEAS. UNIT FLOW**

It specifies the instantaneous flow measurement unit. Default: m3/h.

Range: l/s; l/m; l/h; l/D; m3/s; m3/m; m3/h; m3/D; GAL/s;

GAL/m; GAL/H; GAL/D; FT3/s; FT3/m; FT3/H; FT3/D;

IMPGAL/s; IMPGAL/m; IMPGAL/H; IMPGAL/D; Ml/D;

MGAL/D; TON/H; KG/H.

Press ENTER key, the display will be as shown here next.

With UP ARROW or SCROLL select the option.

Press ENTER to confirm.

The ☺ to confirm the parameter edit storage.

**10.4.2.3 - FLOW DIGIT**

It indicates how many decimals are displayed after the decimal point.

Default: 2

Range: 1÷3

Press ENTER key, the display will be as shown here next.

With UP ARROW or SCROLL select the option.

Press ENTER to confirm.

The ☺ to confirm the parameter edit storage.

**10.4.2.4 - MEAS. UNIT TOT**

It specifies how many decimals are displayed after the decimal point.

Default: m3

Range: l; m3; gal; ft3;impGal; Ml; Mgal;

Press ENTER key, the display will be as shown here next.

With UP ARROW or SCROLL select the option.

Press ENTER to confirm.

The ☺ to confirm the parameter edit storage.

**10.4.2.5 - TOT DIGIT**

It specifies how many decimals are displayed after decimal point.

Default: 0

Range: 1÷3

Press ENTER key, the display will be as shown here next.

With UP ARROW or SCROLL select the option.

Press ENTER to confirm.

The ☺ to confirm the parameter edit storage.

BASIC SETUP

DAMPING

▶ MEAS UNIT FLOW  
FLOW DIGIT

MEAS. UNIT FLOW

**m3/h**

BASIC SETUP

DAMPING

▶ MEAS UNIT FLOW  
FLOW DIGIT

FLOW DIGIT

**2**

BASIC SETUP

MEAS. UNIT FLOW  
FLOW DIGIT

▶ MEAS. UNIT TOT.

MEAS. UNIT TOT.

l

m3

▶ gal

BASIC SETUP

FLOW DIGIT

MEAS. UNIT TOT.

▶ TOT. DIGIT

TOT. DIGIT

**0**

10.4.3 - SYSTEM SETUP

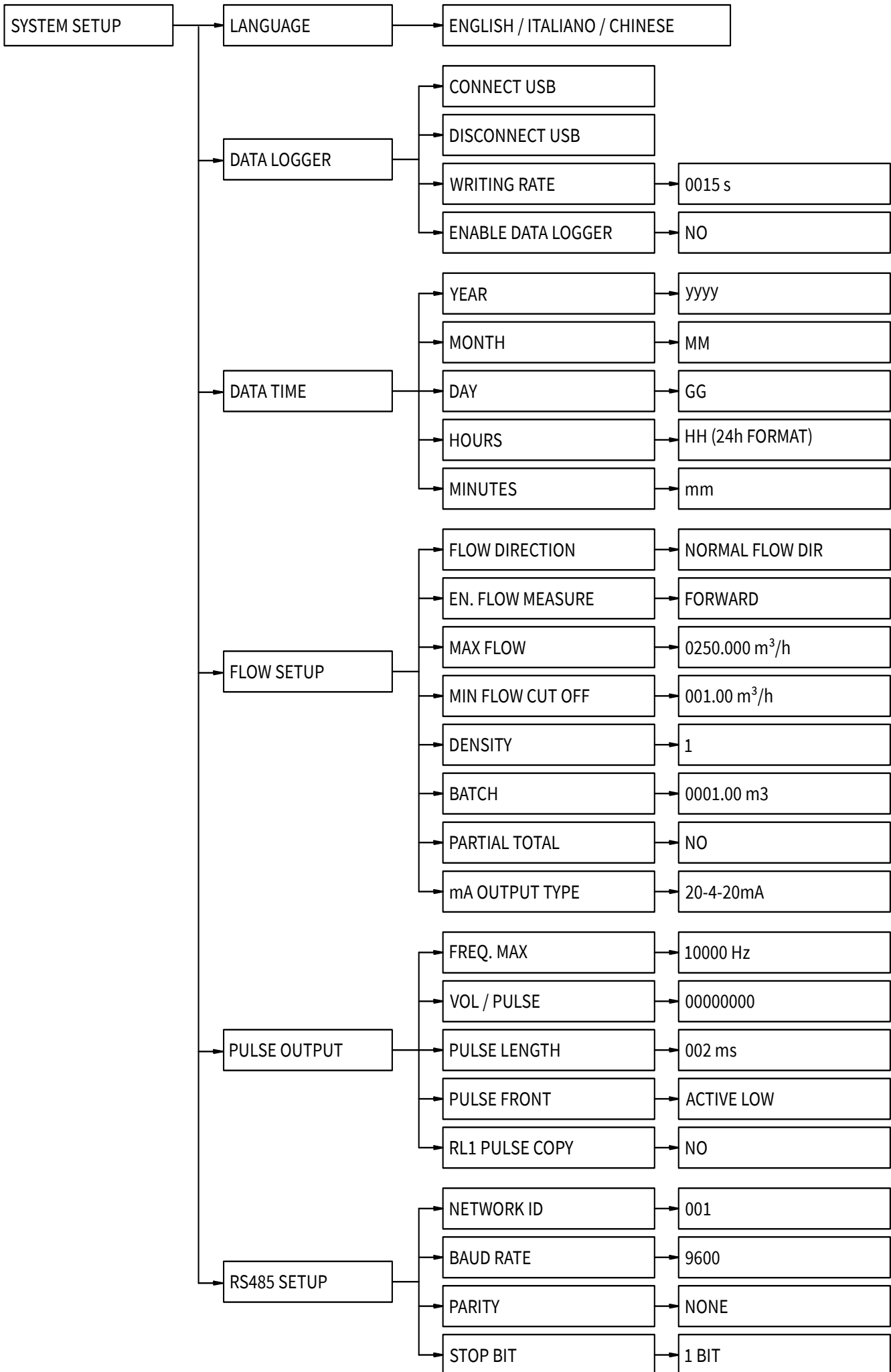

**10.4.4 - SYSTEM CONFIGURATION (SYSTEM SETUP)**

Press ENTER key from run mode: the display will be as shown here next, then press SCROLL key to select “SYSTEM SETUP” menu and press ENTER to enter.

Press UP ARROW or SCROLL keys to select the desired function and press ENTER key to access.

**10.4.4.1 - LANGUAGE**

Allows menu language selection.

Default: ENGLISH; Range: ENGLISH - ITALIANO – CHINESE

Press ENTER key, the display will be as shown here next.

With UP ARROW or SCROLL select the option.  
Press ENTER to confirm.

The ☺ to confirm the parameter edit storage.

**10.4.4.2 - DATA LOGGER (OPT.)**

The USB pen drive data logger function is set in this menu.  
Press ENTER to confirm.

The display will be as shown here next.  
Press UP ARROW or SCROLL keys to select the desired function and press ENTER key to access.

**10.4.4.2.1 - CONNECT USB**

Connect the pen drive to the USB port.

Press ENTER, after the “WAIT” message, the “USB CONNECTED” message will appear. If the “USB NOT FOUND” message is displayed, verify that the pen drive is inserted correctly into the USB port.

MENU  
BASIC SETUP  
▶ SYSTEM SETUP  
TEST

SYSTEM SETUP  
▶ LANGUAGE  
DATA LOGGER  
DATA TIME

LANGUAGE  
▶ ENGLISH  
ITALIANO  
CHINESE

SYSTEM SETUP  
LANGUAGE  
▶ DATA LOGGER  
DATA TIME

DATA LOGGER  
▶ CONNECT USB  
DISCONNECT USB  
WRITING RATE

DATA LOGGER  
▶ CONNECT USB  
DISCONNECT USB  
WRITING RATE

USB CONNECTED

**10.4.4.2.2 - DISCONNECT USB**

Disconnect the pen drive to the USB port.

Press ENTER ,after the “WAIT” message, the “REMOVE USB “ message will appear”.

```

DATA LOGGER
CONNECT USB
▶ DISCONNECT USB
WRITING RATE
  
```

```

REMOVE USB
  
```

**10.4.4.2.3 - WRITING RATE**

Set the time interval between a storage and the next.

Default: 60s

Range: 15÷3600s

Press ENTER key, the display will be as shown here next.

With UP ARROW change the digit, with SCROLL moves the cursor.

Press ENTER to confirm.

The ☺ to confirm the parameter edit storage.

```

DATA LOGGER
CONNECT USB
DISCONNECT USB
▶ WRITING RATE
  
```

```

WRITING RATE

0060s
  
```

**10.4.4.2.4 - ENABLE DATALOGGER**

Enables or disables the data logger function.

Press ENTER key, the display will be as shown here next.

With UP ARROW or SCROLL select the option.

Press ENTER to confirm.

The ☺ to confirm the parameter edit storage.

```

DATA LOGGER
DISCONNECT USB
WRITING RATE
▶ ENABLE DATA LOGGER
  
```

```

ENABLE DATA LOGGER

NO
▶ YES
  
```

**10.4.4.3 - DATE TIME**

In the system clock and the calendar are set in this menu.

The display will be as shown here next.

Press UP ARROW or SCROLL keys to select the desired function and press ENTER per accedervi.

```

SYSTEM SETUP
LANGUAGE
DATA LOGGER
▶ DATA TIME
  
```

```

DATA TIME
▶ YEAR
MONTH
DAY
  
```

**10.4.4.3.1 - YEAR**

Sets the year in the yyyy format.

Press ENTER key, the display will be as shown here next.

With UP ARROW change the digit, with SCROLL moves the cursor.

Press ENTER to confirm.

The ☺ to confirm the parameter edit storage.

```

DATA TIME
▶ YEAR
MONTH
DAY
  
```

```

YEAR

2016
  
```

**10.4.4.3.2 - MONTH**

Sets the month in the MM format.

Press ENTER key, the display will be as shown here next.

With UP ARROW change the digit, with SCROLL moves the cursor.

Press ENTER to confirm.

The ☺ to confirm the parameter edit storage.

```

          DATA TIME
YEAR
▶ MONTH
DAY
  
```

```

          MONTH
          02
  
```

**10.4.4.3.3 - DAY**

Sets the day in the dd format.

Press ENTER key, the display will be as shown here next.

With UP ARROW change the digit, with SCROLL moves the cursor.

Press ENTER to confirm.

The ☺ to confirm the parameter edit storage.

```

          DATA TIME
YEAR
MONTH
▶ DAY
  
```

```

          DAY
          12
  
```

**10.4.4.3.4 - HOURS**

Sets the hours in the HH format.

Press ENTER key, the display will be as shown here next.

With UP ARROW change the digit, with SCROLL moves the cursor.

Press ENTER to confirm.

The ☺ to confirm the parameter edit storage.

```

          DATA TIME
MONTH
DAY
▶ HOURS
  
```

```

          HOURS
          16
  
```

**10.4.4.3.5 - MINUTES**

Sets the minutes in the mm format.

Press ENTER key, the display will be as shown here next.

With UP ARROW change the digit, with SCROLL moves the cursor.

Press ENTER to confirm.

The ☺ to confirm the parameter edit storage.

```

          DATA TIME
DAY
HOURS
▶ MINUTES
  
```

```

          MINUTES
          48
  
```

**10.4.4.4 - FLOW SETUP**

The configuration parameters of the flow measurement are set in this menu

Press ENTER to access.

The display will be as shown here next.

Press UP ARROW or SCROLL keys to select the desired function and press ENTER key to access

**10.4.4.4.1 - FLOW DIRECTION**

Set what is the positive flow direction compared to the arrow on the sensor pipe.

Default: NORMAL FLOW DIR

Range: NORMAL FLOW DIR; INVERT FLOW DIR

Press ENTER key, the display will be as shown here next.

With UP ARROW or SCROLL select the option.

Press ENTER to confirm.

The ☺ to confirm the parameter edit.

**10.4.4.4.2 - EN. FLOW MEASURE**

This parameter enables the flow direction measurement and its related totalizer

Default: BIDIREC (bidirectional)

Range: FORWARD; REVERSE; BIDIREC (bidirectional).

Press ENTER key, the display will be as shown here next.

With UP ARROW or SCROLL select the option.

Press ENTER to confirm.

The ☺ to confirm the parameter edit.

**10.4.4.4.3 - MAX FLOW**

Set the flow measurement 100%.

This value adjusts the analog output end scale (20mA) and the frequency output end scale.

The range is related to the sensor DN.

The default value is the maximum flow rate for the MID approval according to the sensor pipe DN.

Press ENTER key, the display will be as shown here next.

With UP ARROW change the digit, with SCROLL moves the cursor.

Press ENTER to confirm.

The ☺ to confirm the parameter edit storage.

<p><u>SYSTEM SETUP</u> DATA LOGGER DATA TIME ▶ FLOW SETUP</p>
<p><u>FLOW SETUP</u> ▶ FLOW DIRECTION EN. FLOW MEASURE MAX FLOW</p>
<p><u>FLOW SETUP</u> ▶ FLOW DIRECTION EN. FLOW MEASURE MAX FLOW</p>

<p><u>FLOW DIRECTION</u> ▶ NORMAL FLOW DIR. INVERT FLOW DIR.</p>
--

<p><u>FLOW SETUP</u> FLOW DIRECTION ▶ EN. FLOW MEASURE MAX FLOW</p>
---

<p><u>EN. FLOW MWAASURE</u> FORWARD REVERSE ▶ BIDIREC</p>
---

<p><u>FLOW SETUP</u> ▶ FLOW DIRECTION EN. FLOW MEASURE MAX FLOW</p>
---

<p>MAX FLOW  <b>000250.00</b> m3/h</p>
--

**10.4.4.4.4 - MIN FLOW CUT OFF**

It specifies the Qmax% value below which the instantaneous flow measurement reading (direct or reverse) and the outputs are forced to zero. The default is 1% of the declared maximum flow rate for the MID approval according to the sensor pipe DN.

Press ENTER key, the display will be as shown here next.  
With UP ARROW change the digit, with SCROLL moves the cursor.  
Press ENTER to confirm.  
The ☺ to confirm the parameter edit storage.

```

FLOW SETUP
EN. FLOW MEASURE
MAX FLOW
▶ MIN FLOW CUT OFF

```

```

MIN FLOW CUT OFF

000.00
m3/h

```

**10.4.4.4.5 - DENSITY**

Sets the fluid specific weight (g/l) to convert the measured volume value by weight.  
Default: 1000.0 G/L;  
Range: 0000.0÷4000.0 G/L.

Press ENTER key, the display will be as shown here next.  
With UP ARROW change the digit, with SCROLL moves the cursor.  
Press ENTER to confirm.  
The ☺ to confirm the parameter edit storage.

```

FLOW SETUP
MAX FLOW
MIN FLOW CUT OFF
▶ DENSITY

```

```

DENSITY

1000.0
G/L

```

**10.4.4.4.6 - BATCH**

Activating the batch function, the system automatically sets:

- RL1 alarm when the partial batch counter value reaches the set threshold value (relay de-energized with open contact).
- DI is the input for a normally open button; it has the restart function of the batch counter and, at the same time, the resetting of the RL1 contact (energized relay with closed contact)

The unit volume is a function of the MEAS. UNIT TOT parameter setting (totalisers unit)  
Default: 0 (disabled BATCH function);  
Range: 0000.00÷9999.99.

Press ENTER key, the display will be as shown here next.  
With UP ARROW change the digit, with SCROLL moves the cursor.  
Press ENTER to confirm.  
The ☺ to confirm the parameter edit storage.

```

FLOW SETUP
MIN FLOW CUT OFF
DENSITY
▶ BATCH

```

```

BATCH

0001.0
m3

```

In RUN mode, pressing the UP ARROW key, is possible to monitor the count, and the output relay status:

- Predetermined batch value.
- Counted value.
- Instantaneous flow rate value.
- RL1 relay output state (energized with closed contact).

When the counter (b) reaches the batch predetermined value (a), RL1 is de-energized instantaneously, and the display shows:

- Predetermined batch value.
- The counted value is highlighted to indicate that the predetermined batch value has been reached (or exceeded).
- Instantaneous flow rate value.
- RL1 relay output state (de-energized with closed contact).

By pressing the button (normally open) connected to DI, the batch is restarted, the counter is reset (b) and RL1 output is rearmed (relay energized with closed contact).

#### 10.4.4.4.7 - PARTIAL TOTAL

Activating the PARTIAL TOTALIZER function, the system automatically sets the DI input for normally open button or the LEFT ARROW to start, stop and reset of the totalizer.

The unit volume is a function of the MEAS. UNIT TOT parameter setting (totalizer unit).

Default: NO (Disabled poartial totalizer)

Range: NO;SI.

Press ENTER key, the display will be as shown here next.

With UP ARROW changes the digit, with SCROLL moves the cursor.

Press ENTER to confirm.

The ☺ to confirm the parameter edit storage.

In run mode, pressing the UP ARROW key is possible to monitor the count.

Press the button (N.O.) connected to the DI input or the LEFT ARROW to get start the counting: pressing again the button, the counter is stopped and pressing once again the button, the partial totalizer will be resetted.

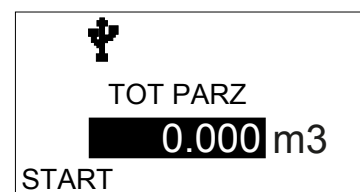
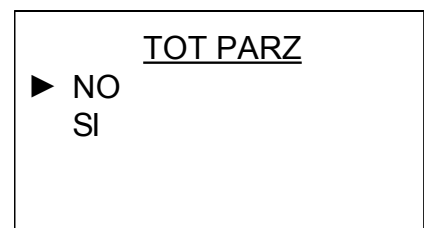
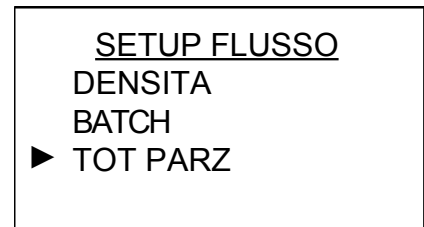
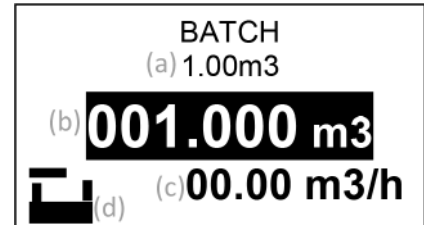
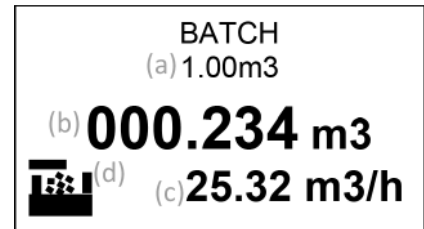



**10.4.4.4.8 - mA OUTPUT TYPE**

With a set value of 20-4-20mA the analog output generates 4mA with zero instantaneous flow and 20mA with positive or negative instantaneous flow, corresponding to the value set in “MAX FLOW”;

With a set value of 4-12-20mA the analog output generates 4mA with negative instantaneous flow corresponding to the value set in “MAX FLOW”, 12mA with zero instantaneous flow and 20mA with positive instantaneous flow corresponding to the value set in “MAX FLOW”.

Default value: 20-4-20mA

Range: 20-4-20mA; 4-12-20mA

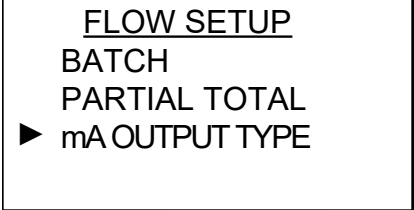
**10.4.4.5 - PULSE OUTPUT**

The F/P digital output parameters are set in this menu.

Press ENTER to access.

The display will be as shown here next.

Press UP ARROW or SCROLL keys to select the desired function and press ENTER key to access

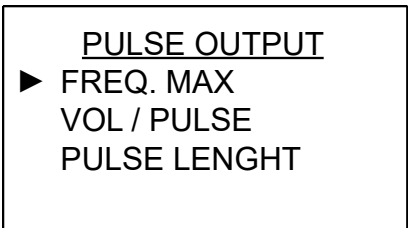
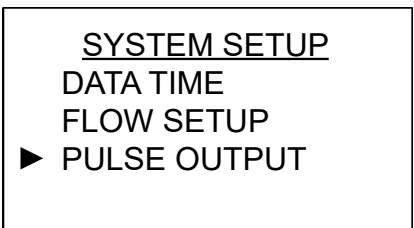
**10.4.4.5.1 - FREQ. MAX**

Sets the maximum frequency in relation to MAX FLOW.

The digital output is active as a frequency output only when the parameter “VOL/PULSE” is set to 0

Default: 10000Hz;

Range: 100÷10000 Hz.

Press ENTER key, the display will be as shown here next.

With UP ARROW change the digit, with SCROLL moves the cursor.

Press ENTER to confirm.

The ☺ to confirm the parameter edit storage.

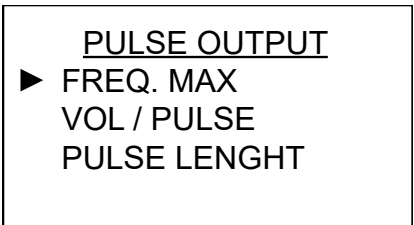

**10.4.4.5.2 - VOLUME/PULSE**

Sets the volume per pulse. When this parameter is set to 0, the digital output is active as a frequency output (see "FREQ. MAX"). The measurement unit depends on the setting to MEAS. UNIT TOT parameter.

Default: 0000.00; Range: 0000.00÷9999.99

Press ENTER key, the display will be as shown here next.  
With UP ARROW change the digit, with SCROLL moves the cursor.  
Press ENTER to confirm.

The ☺ to confirm the parameter edit storage.

```

DIGITAL OUTPUT
FREQ. MAX
▶ VOL / PULSE
PULSE LENGHT

```

```

VOL/PULSE

0000.00
M3

```

**10.4.4.5.3 - PULSE LENGTH**

Sets the pulse width in ms.

Default: 0002ms; Range: 0001÷100ms

Press ENTER key, the display will be as shown here next.  
With UP ARROW change the digit, with SCROLL moves the cursor.  
Press ENTER to confirm.

The ☺ to confirm the parameter edit storage.

```

DIGITAL OUTPUT
FREQ. MAX
VOL / PULSE
▶ PULSE LENGHT

```

```

PULSE LENGHT

002
ms

```

**10.4.4.5.4 - PULSE FRONT**

Sets the pulse output energy level.

When set ACTIVE LOW the pulse count is low, when set ACTIVE HIGH, the pulse count is high.

Default: ACTIVE LOW; Range: ACTIVE LOW; ALTO.

Press ENTER key, the display will be as shown here next.  
With UP ARROW or SCROLL select the option.  
Press ENTER to confirm.

The ☺ to confirm the parameter edit storage.

```

DIGITAL OUTPUT
VOL / PULSE
PULSE LENGHT
▶ PULSE FRONT

```

```

PULSE FRONT

▶ ACTIVE LOW
ACTIVE HIGH

```

**10.4.4.5.5 - RL1 PULSE COPY**

It duplicates the function set in "VOLUME/PULSE".

Selecting "YES", the digital output and the RL1 output simultaneously launch the pulse signal of the increasing of the totalized volume.

Default: NO

Options: NO - YES

DIGITAL OUTPUT  
PULSE LENGHT  
PULSE FRONT  
▶ RL1 PULSE COPY

RL1 PULSE COPY  
▶ NO  
YES

**10.4.4.6 - RS485 SETUP**

The configuration parameters of the RS485 port are set in this menu.

Press ENTER to access.

The display will be as shown here next.

Press UP ARROW or SCROLL keys to select the desired function and press ENTER key to access

SYSTEM SETUP  
FLOW SETUP  
PULSE OUTPUT  
▶ RS485 SETUP

RS485 SETUP  
▶ NETWORK ID  
BAUD RATE  
PARITY

**10.4.4.6.1 - NETWORK ID**

Set the unity UID in RS485 network

Default: 001

Range: 001÷247.

Press ENTER key, the display will be as shown here next.

With UP ARROW change the digit, with SCROLL moves the cursor.

Press ENTER to confirm.

The ☺ to confirm the parameter edit storage.

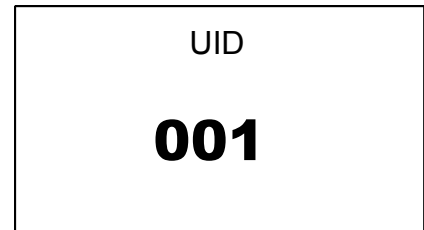
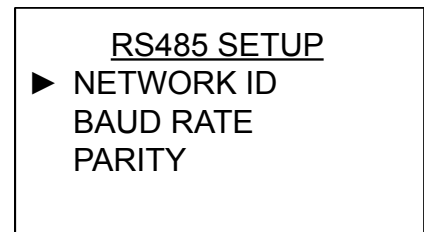
**10.4.4.6.2 - BAUD RATE**

Sets the RS485 output Baud Rate.

Default: 9600; Range: 9600; 19200.

Press ENTER key, the display will be as shown here next.

With UP ARROW or SCROLL select the option.

Press ENTER to confirm.

The ☺ to confirm the parameter edit.

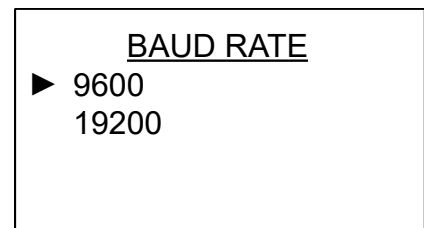
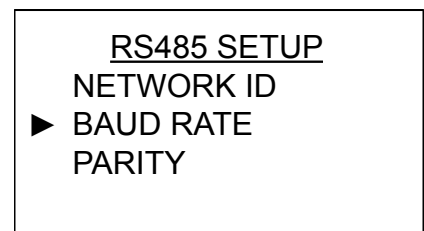
**10.4.4.6.3 - PARITY**

Sets the RS485 output Parity.

Default: NONE

Range: NONE; ODD; EVEN.

Press ENTER key, the display will be as shown here next.

With UP ARROW or SCROLL select the option.

Press ENTER to confirm.

The ☺ to confirm the parameter edit.

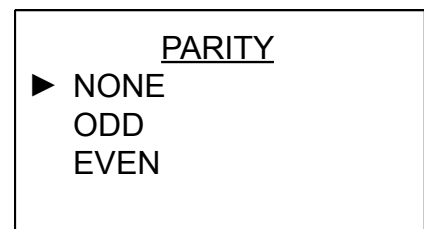
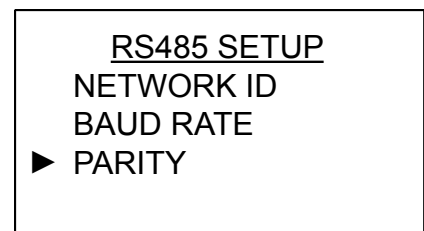
**10.4.4.6.4 - STOP BITS**

Sets the RS485 output Stop Bit

Default: 1 BIT

Range: 1 BIT; 2 BITS.

Press ENTER key, the display will be as shown here next.

With UP ARROW or SCROLL select the option.

Press ENTER to confirm.

The ☺ to confirm the parameter.

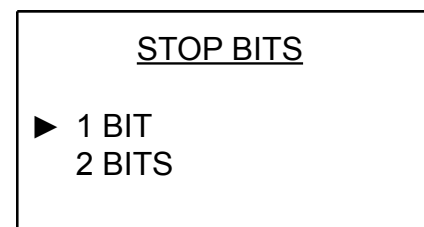
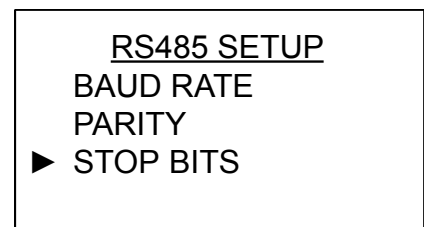

### 10.4.5 - TEST menu

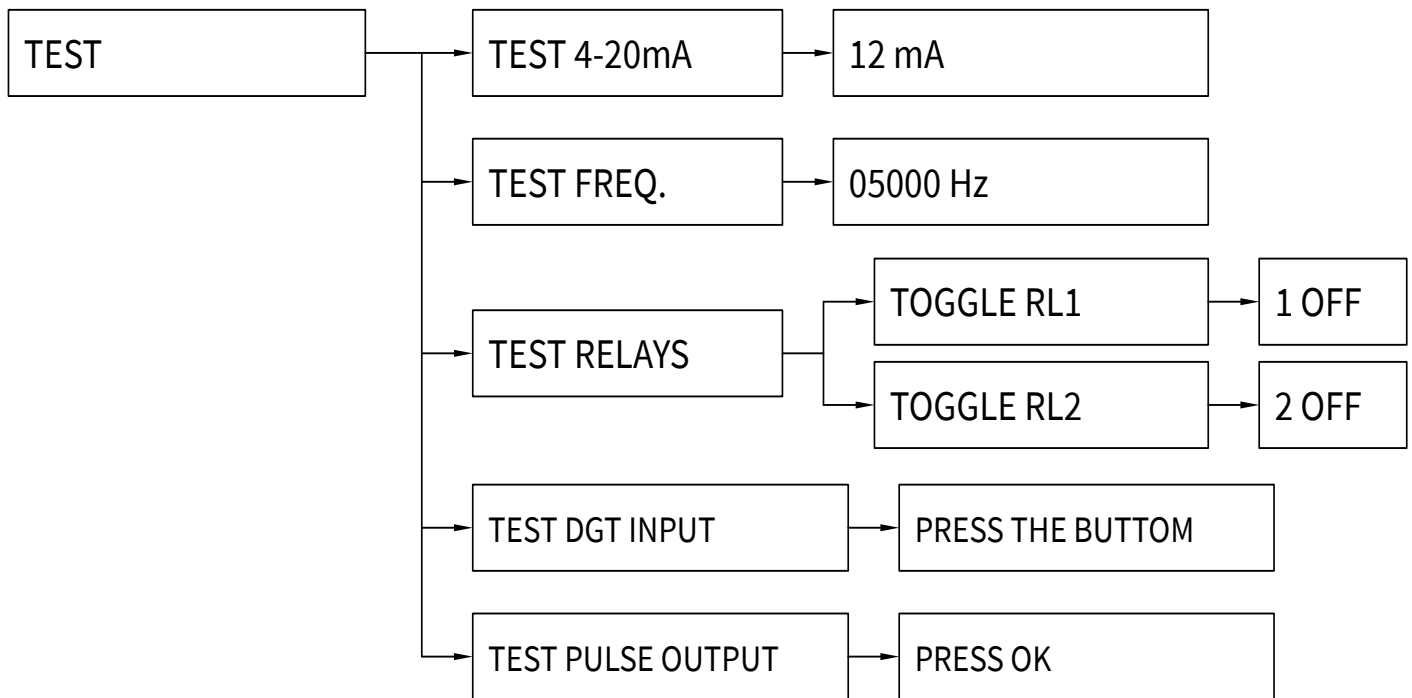

### 10.4.6 - OUTPUT SIGNAL TEST (TEST)

Press ENTER key from run mode: the display will be as shown here next, then press SCROLL key to select “SYSTEM SETUP” menu and press ENTER to enter.

Press UP ARROW or SCROLL keys to select the desired function and press ENTER key to access.

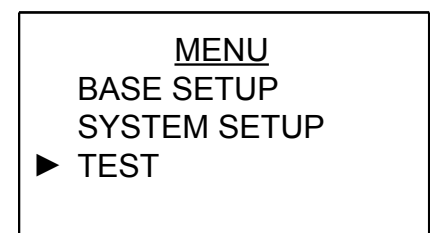

#### 10.4.6.1 - TEST 4-20mA

“TEST 4-20mA” force the 4÷20mA signal output to the value set for the test  
 Example: Setting the testing value at 16.2 mA, the actual output signal value is forced to 16.2mA.

When exiting the TEST function, the 4-20mA output signal returns to be a in compliance with the actual measurement FLOW set function..

Default: 12mA. Range: 4÷20mA

Press ENTER key, the display will be as shown here next.

With UP ARROW change the digit, with SCROLL moves the cursor.

Press ENTER to confirm the test value.

Press LEFT ARROW to exit.

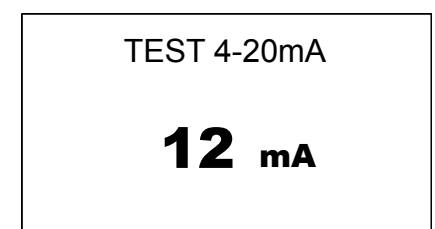
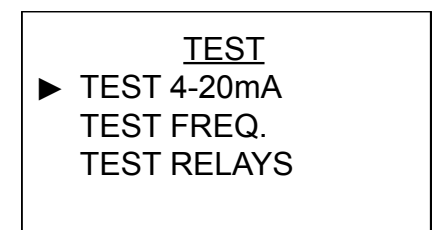

**10.4.6.2 - TEST FREQ**

“TEST FREQ” force the frequency signal output to the value set for the test.

Example: Setting the testing value at 2000Hz, the actual output signal value is forced to 2000Hz. When exiting the TEST function, the frequency output signal returns to be a in compliance with the actual measurement flow set function.. Default: 5000 Hz.

Range: 0÷10000 Hz

Press ENTER key, the display will be as shown here next.

With UP ARROW change the digit, with SCROLL moves the cursor.

Press ENTER to confirm the test value.

Press LEFT ARROW to exit.

```

TEST
TEST 4-20mA
▶ TEST FREQ.
TEST RELAYS
  
```

```

TEST FREQ.

05000
      Hz
  
```

**10.4.6.3 - TEST RELE**

Test the RL1 and RL2 relay outputs is possible in this menu.

Press ENTER to access.

The display will be as shown here next.

Press UP ARROW or SCROLL keys to select the desired function and press ENTER key to access.

```

TEST
TEST 4-20mA
TEST FREQ.
▶ TEST RELAYS
  
```

```

TEST RELAYS
▶ TOGGLE RL1
  TOGGLE RL2
  
```

**10.4.6.3.1 - TOGGLE RL1/2**

Forcing the status change of the output RL1/2 relay.

Press ENTER key, the display will be as shown here next.

Press ENTER to switch from the OFF state to the ON state.

Press LEFT ARROW to exit.

```

TEST RELAYS
▶ TOGGLE RL1
  TOGGLE RL2
  
```

```

1 OFF / ON
  
```

**10.4.6.4 - TEST DGT INPUT**

To verify the “D.I.” digital input funcion.

Not available on this instruments.

**10.4.6.5 - TEST PULSE OUTPUT**

To verify the F/P pulse output funcionalidad.

Each time the ENTER key is pressed, the F/P output generates a pulse with a length equal to what set in the “PULSE LENGTH ms” parameter, and simultaneously increments the test counter shown in the display center.

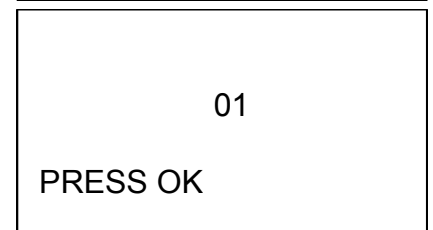
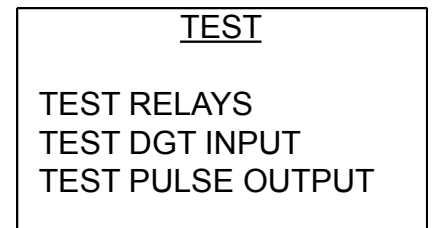
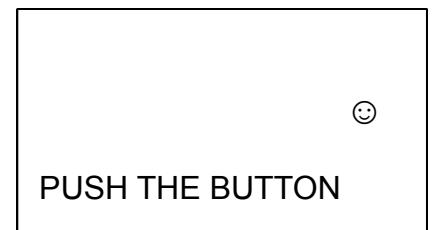
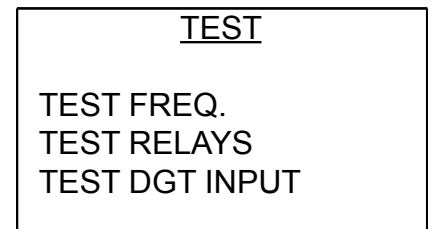

## 10.4.7 - Menù. INFO

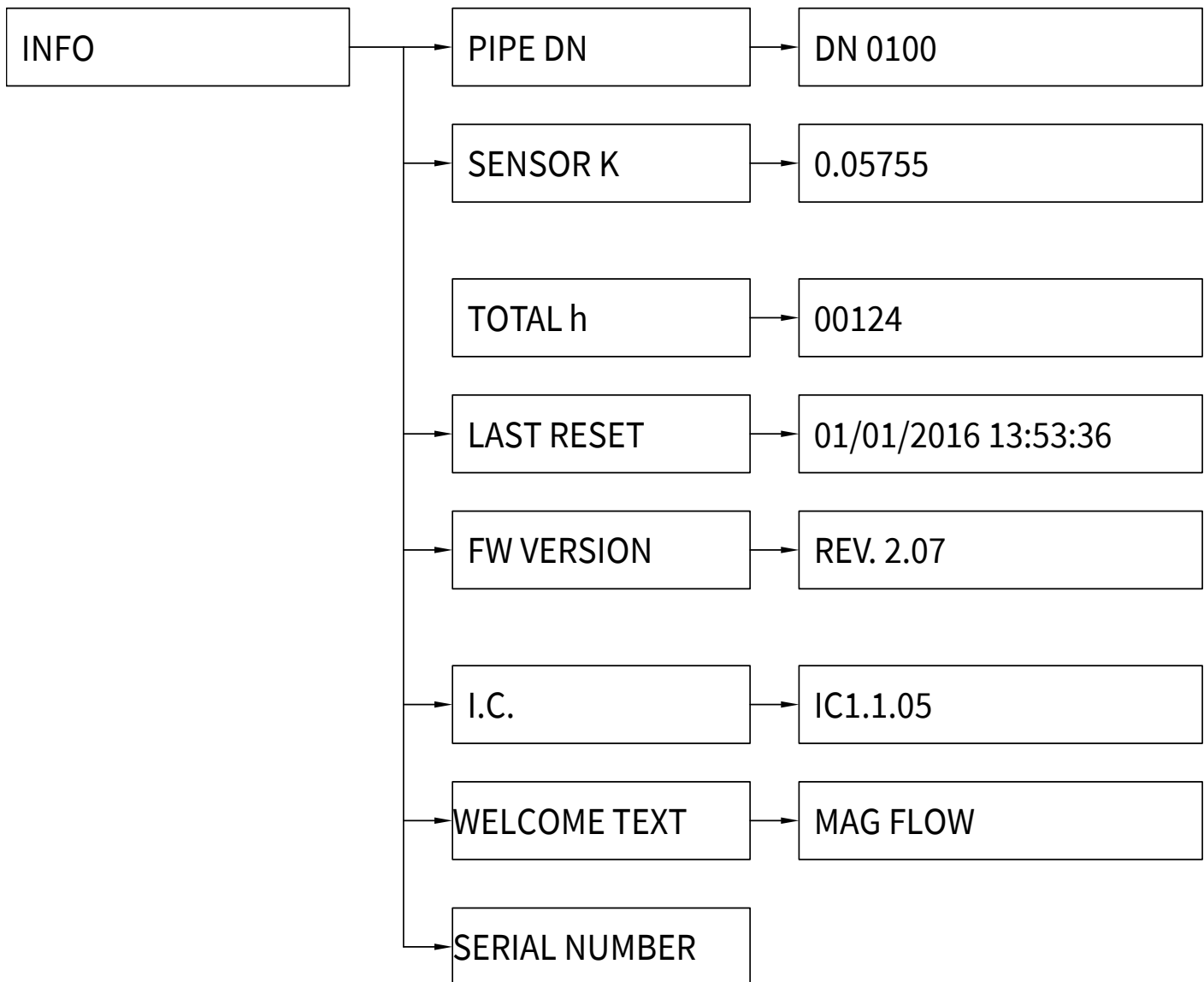

## 10.4.8 - SYSTEM INFORMATION (INFO)

Press ENTER key from run mode: the display will be as shown here next, then press SCROLL key to select "INFO" menu and press ENTER to enter.

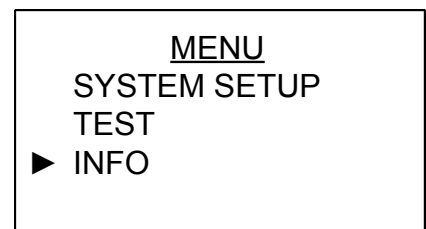

Press UP ARROW or SCROLL keys to select the desired function and press ENTER key to access.

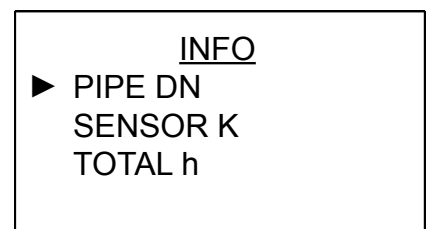



**10.4.8.1 - PIPE DN**

Press ENTER to access.

It is useful to check correspondence with the “Connection” data reported on the adhesive rating plate located on the sensor pipe. The display shows the set DN of the measuring pipe.

```

INFO
▶ PIPE DN
  SENSOR K
  TOTAL h

```

```

PIPE DN

DN0100

```

**10.4.8.2 - SENSOR K**

Press ENTER to access.

It is useful to check correspondence with the “SENSOR K” data reported on the adhesive rating plate located on the sensor pipe. The display shows the set SENSOR K of the measuring pipe.

```

INFO
PIPE DN
▶ SENSOR K
  TOTAL h

```

```

SENSOR K

0.05755

```

**10.4.8.3 - TOTAL h**

Press ENTER to access.

The display shows the total hours of the flowmeter operation.

```

INFO
PIPE DN
  SENSOR K
▶ TOTAL h

```

```

TOTAL h

00251

```

**10.4.8.4 - LAST RESET**

Press ENTER to access.

The display shows the date and time of the last reset of the totalizer.

```

INFO
SENSOR K
  TOTAL h
▶ LAST RESET

```

```

LAST RESET

01/01/2016 13:53:36

```

**10.4.8.5 - FW VERSION**

Press ENTER to access.

```

INFO
TOTAL h
LAST RESET
▶ FW VERSION

```

The display shows the firmware version.

```

MAG FLOW

FW Rev. 2.07

```

**10.4.8.6 - I.C.**

Press ENTER to access.

```

INFO
LAST RESET
FW VERSION
▶ I.C.

```

The display shows the configuration index (I.C.) of the flowmeter.

```

I.C.

IC1.1.05

```

**10.4.8.7 - WELCOME TEXT**

Press ENTER to access.

```

INFO
FW VERSION
I.C.
▶ WELCOME TEXT

```

The display will be as shown here next.

With UP ARROW/SCROLL change the digit, with ENTER moves the cursor.

To confirm press ENTER until the cursor reaches the end of second row and automatically comes back to info menu.

```

WELCOME TEXT

SGM-LEKTRA

MAG FLOW

```

**10.4.9 - CALIBRATION Menu.**

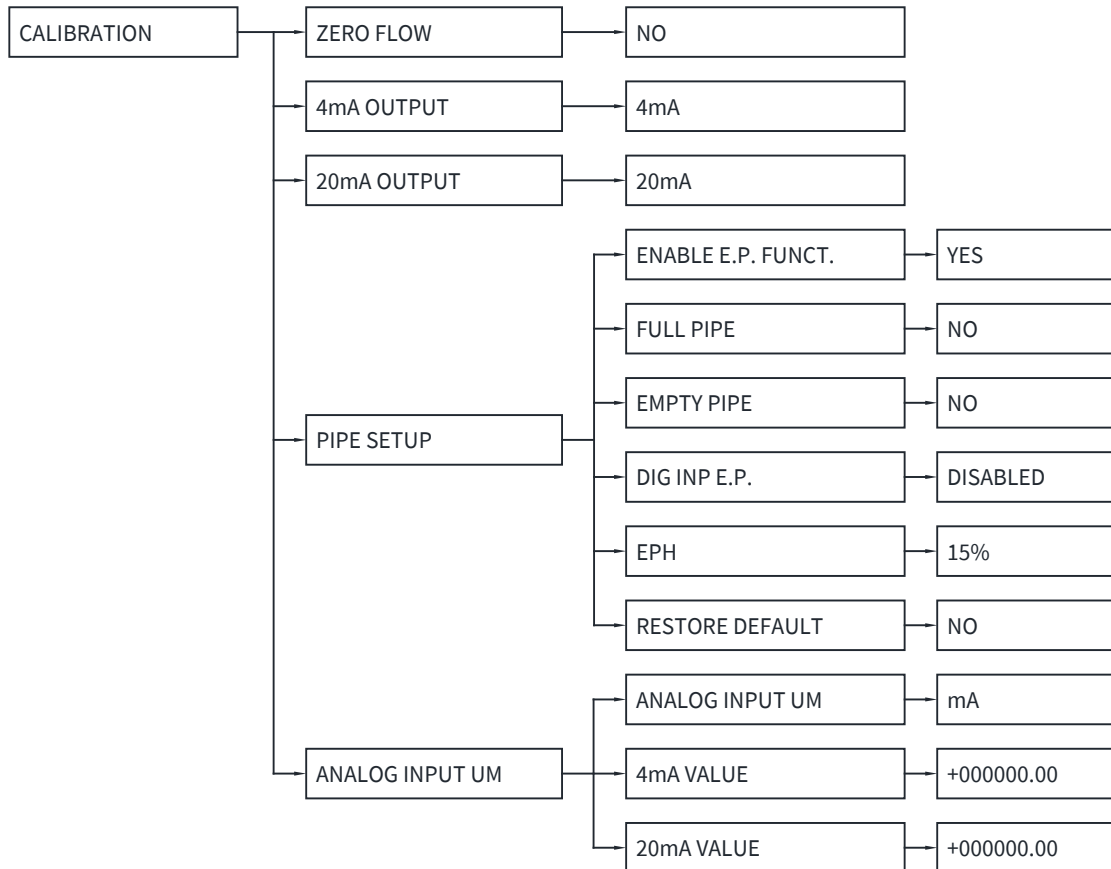

**10.4.10 - SYSTEM CALIBRATION (CALIBRATION)**

Press ENTER key from run mode: the display will be as shown here next, then press SCROLL key to select “CALIBRATION” menu and press ENTER key to access.

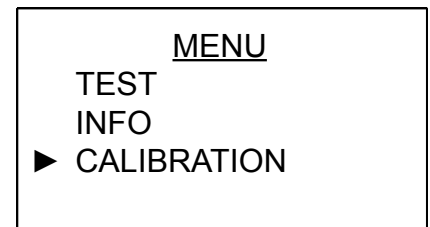

Press UP ARROW or SCROLL keys to select the desired function and press ENTER key to access.

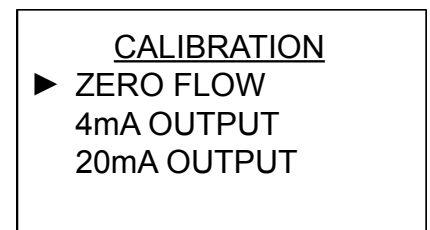

**10.4.10.1 - ZERO FLOW**

Zero flow measurement calibrate.  
The sensor must be full and the flow stopped.  
Default: NO Range: YES - NO.

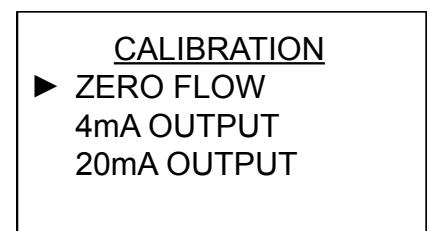

Press ENTER key, the display will be as shown here next.  
With UP ARROW or SCROLL select the option.  
Premere ENTER o confirm.

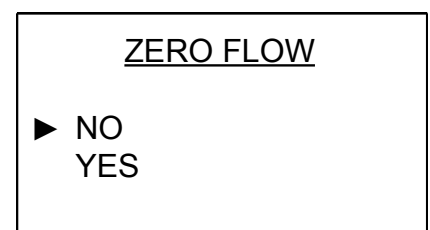

**10.4.10.2 - 4mA OUTPUT**

Performs calibration of 4mA

Press ENTER key, the display will be as shown here next.

Connect a mA meter to the analog output; if the detected current measurement is different from 4 mA it is possible to correct the value of the output current with UP ARROW (UP) or SCROLL (DOWN).

Press ENTER (OK) to confirm.

```

CALIBRATION
ZERO FLOW
▶ 4mA OUTPUT
20mA OUTPUT
  
```

```

4mA

UP DOWN OK
  
```

**10.4.10.3 - 20mA OUTPUT**

Performs calibration of 20mA.

Press ENTER key, the display will be as shown here next.

Connect a mA meter to the analog output; if the detected current measurement is different from 20 mA it is possible to correct the value of the output current with UP ARROW (UP) or SCROLL (DOWN).

Press ENTER (OK) to confirm.

```

CALIBRATION
ZERO FLOW
4mA OUTPUT
▶ 20mA OUTPUT
  
```

```

20mA

UP DOWN OK
  
```

**10.4.10.4 - PIPE SETUP**

Performs the calibration of empty pipe sensitivity press ENTER to access.

The display will be as shown here next.

press UP arrow or SCROLL keys to select the desired function and press ENTER key to access.

```

CALIBRATION
4mA OUTPUT
20mA OUTPUT
▶ PIPE SETUP
  
```

```

PIPE SETUP
▶ ENABLE E.P. FUNCT.
FULL PIPE
EMPTY PIPE
  
```

**10.4.10.4.1 - ENABLE E.P. FUNCT.**

Enables or disables the empty pipe detection.

Default: YES

Range: YES - NO

Press ENTER key, the display will be as shown here next.

With UP arrow or SCROLL select the option.

Press ENTER to confirm.

```

PIPE SETUP
▶ ENABLE E.P. FUNCT.
FULL PIPE
EMPTY PIPE
  
```

```

ENABLE E.P. FUNCT.
▶ NO
YES
  
```

**10.4.10.4.2 - FULL PIPE**

ATTENTION: pipe must be full before continue.

Performs a full pipe recognition self calibration.

Default: NO Range: YES - NO.

Press ENTER key, the display will be as shown here next.

With UP ARROW or SCROLL select the option.

Press ENTER to confirm.

The successful calibration is confirmed by the **OK** symbol.

**10.4.10.4.3 - EMPTY PIPE**

ATTENTION: pipe must be empty before continue.

Performs an empty pipe recognition self calibration.

Default: NO Range: YES - NO.

Press ENTER key, the display will be as shown here next.

With UP ARROW or SCROLL select the option.

Press ENTER to confirm.

The successful calibration is confirmed by the **OK** symbol.

**10.4.10.4.4 - EPH**

Sets the system sensibility level to recognize the air presence in the sensor: the higher the value, the greater the sensitivity.

Default: 15%

Range: 010÷90%.

Press ENTER key, the display will be as shown here next.

With UP ARROW change the digit, with SCROLL moves the cursor.

Press ENTER to confirm.

The **☺** to confirm the parameter edit storage.

CALIBRATION  
4mA OUTPUT  
20mA OUTPUT  
▶ FULL PIPE

FULL PIPE  
▶ NO  
YES

CALIBRATION  
20mA OUTPUT  
FULL PIPE  
▶ EMPTY PIPE

EMPTY PIPE  
▶ NO  
YES

PIPE SETUP  
EMPTY PIPE  
DIG INP E.P.  
▶ EPH

EPH  
**15%**

**10.4.10.5 - ANALOG INPUT**

The measuring ranges of the analog inputs can be set in this menu.

Press ENTER to access.

The display will be as shown here next.

Press UP ARROW or SCROLL keys to select the desired function and press ENTER key to access.

**10.4.10.5.1 - ANALOG INPUT UM**

Specifies the measurement unit of analog signals to AN1 and AN2 inputs.

Default: mA; Range: mA; C; F; KPa; Pa; bar; mbar; psi; mH2O; mmH2O; mmHg; atm.

Press ENTER key, the display will be as shown here next.

With UP ARROW or SCROLL select the option.

Press ENTER to confirm.

The ☺ to confirm the parameter edit storage.

CALIBRATION  
20mA OUTPUT  
PIPE SETUP  
▶ ANALOG INPUT

ANALOG INPUT  
▶ ANALOG INPUT UM  
4mA VALUE  
20mA VALUE

ANALOG INPUT  
▶ ANALOG INPUT UM  
4mA VALUE  
20mA VALUE

ANALOG INPUT UM  
▶ mA  
C  
F

**10.4.10.5.2 - 4mA VALUE**

Set the value to be associated to the begin scale of the analog inputs.

Default: +000000.00

Range: -999999.99÷+999999.99.

Press ENTER key, the display will be as shown here next.

With UP ARROW change the digit, with SCROLL moves the cursor.

Press ENTER to confirm.

The © to confirm the parameter edit storage.

**10.4.10.5.3 - 20mA VALUE**

Set the value to be associated to the end scale of the analog inputs.

Default: +000000.00

Range: -999999.99÷+999999.99.

Press ENTER key, the display will be as shown here next.

With UP ARROW change the digit, with SCROLL moves the cursor.

Press ENTER to confirm.

The © to confirm the parameter edit storage.

```

ANALOG INPUT
ANALOG INPUT UM
▶ 4mA VALUE
  20mA VALUE
  
```

```

  4mA VALUE
+000000.00
mA
  
```

```

ANALOG INPUT
ANALOG INPUT UM
  4mA VALUE
▶ 20mA VALUE
  
```

```

  20mA VALUE
+000000.00
mA
  
```

### 10.4.11 - RELAYS SETUP MENU

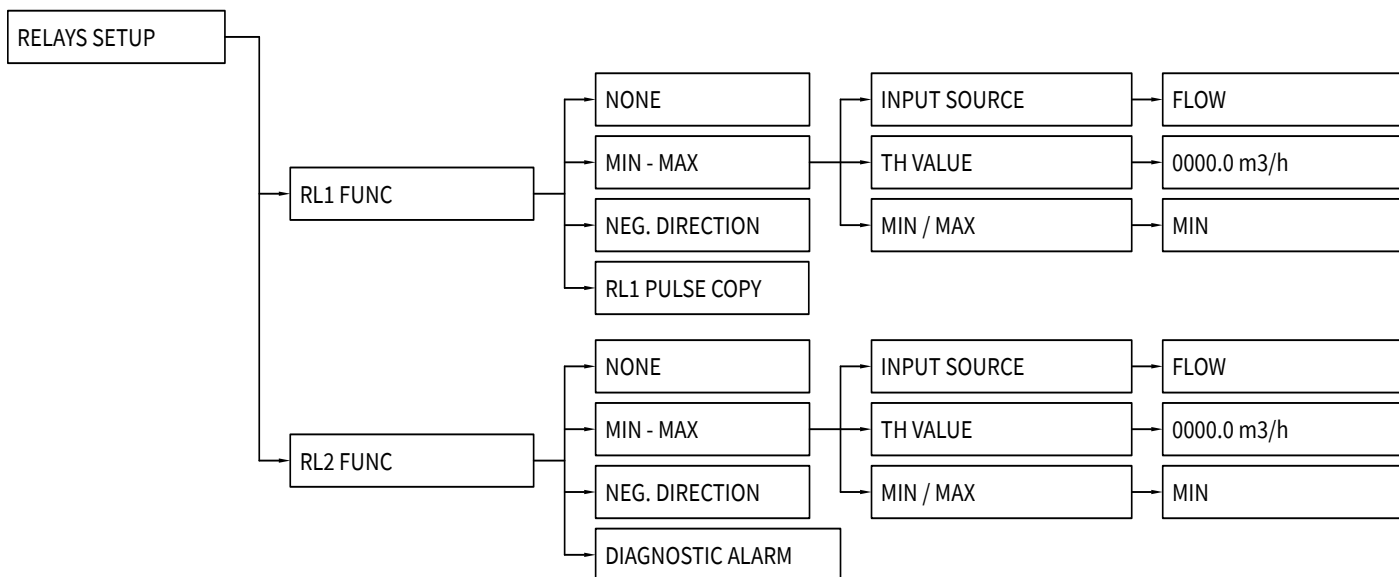

### 10.4.12 - RELAY CONFIGURATION (RELAYS SETUP)

Press ENTER key from run mode: the display will be as shown here next, then press SCROLL key to select “RELAYS SETUP” menu and press ENTER to enter.

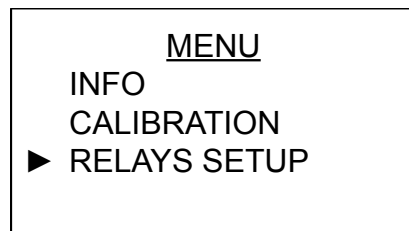

Press UP ARROW or SCROLL keys to select the desired function and press ENTER key to access.

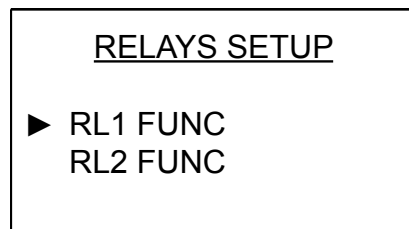

#### 10.4.12.1 - RL1/RL2 FUNC

Submenu for output relay RL1/RL2 settings.

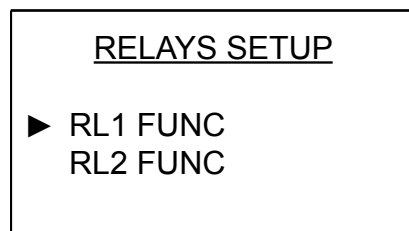

Press UP ARROW or SCROLL keys to select the desired function and press ENTER key to access.

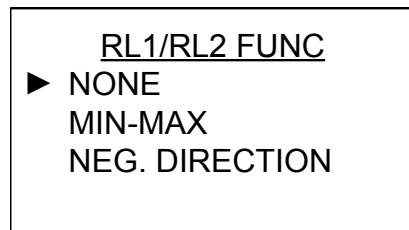

#### 10.4.12.1.1 - NONE

##### Disable the RL1/RL2 output

Press ENTER to confirm.

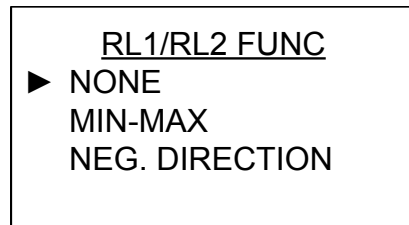



**10.4.12.1.2 - MIN-MAX**

Settings for the activation of the RL1/RL2 alarm

Press UP ARROW or SCROLL keys to select the desired function and press ENTER key to access.

**10.4.12.1.2.1 - INPUT SOURCE**

Associates the alarm signal to a measured variable

Default: FLOW Range: FLOW; ANALOG 1; ANALOG 2;  
ANALOG 1- ANALOG 2

Press ENTER key, the display will be as shown here next.

With UP ARROW or SCROLL select the option.

Press ENTER to confirm.

The ☺ to confirm the parameter edit storage.

**10.4.12.1.2.2 - TH VALUE**

Set the alarm threshold.

The associated measurement unit is in relation to the  
“ INPUT SOURCE “ setting”.

Press ENTER key, the display will be as shown here next.

With UP ARROW change the digit, with SCROLL moves the cursor.

Press ENTER to confirm.

The ☺ to confirm the parameter edit storage.

**10.4.12.1.2.3 - MIN/MAX**

Set the relay operation mode: minimum or maximum alarm  
with relay de-energized and open contact

Default: MIN Range: MIN – MAX

Press ENTER key, the display will be as shown here next.

With UP ARROW or SCROLL select the option.

Press ENTER to confirm.

The ☺ to confirm the parameter edit storage.

```

RL1/RL2 FUNC
NONE
▶ MIN-MAX
NEG. DIRECTION
  
```

```

MIN-MAX
▶ INPUT SOURCE
TH VALUE
MIN/MAX
  
```

```

MIN-MAX
▶ INPUT SOURCE
TH VALUE
MIN/MAX
  
```

```

INPUT SOURCE
▶ FLOW
ANALOG 1
ANALOG 2
  
```

```

MIN-MAX
INPUT SOURCE
▶ TH VALUE
MIN/MAX
  
```

```

TH VALUE
0010.00
m3/h
  
```

```

MIN-MAX
INPUT SOURCE
TH VALUE
▶ MIN/MAX
  
```

```

MIN/MAX
▶ MIN
MAX
  
```

**10.4.12.1.3 - NEG. DIRECTION**

Activate the RL1/RL2 output as a reverse instantaneous negative flow rate alarm.

Press ENTER to confirm.

```

RL1 FUNC
NONE
MIN-MAX
▶ NEG. DIRECTION
  
```

**10.4.12.1.4 - RL1 PULSE COPY  
(available only in menu "RL1 FUNCTION")**

It duplicates the function set in VOLUME/PULSE".

Selecting "YES", the digital output and the RL1 output simultaneously launch the pulse signal of the increasing of the totalized volume.

Press ENTER to confirm.

```

RL1 FUNC
MIN-MAX
NEG. DIRECTION
▶ RL1 PULSE COPY
  
```

**10.4.12.1.5 - DIAGNOSTIC ALARM  
(available only in menu "RL2 FUNCTION")**

It activates the RL2 output for system alarm: coil connection interruption and empty pipe.

Press ENTER to confirm.

```

RL2 FUNC
MIN-MAX
NEG. DIRECTION
▶ DIAGNOSTIC ALARM
  
```

## 11-TROUBLESHOOTING

Problems in the magnetic flowmeter system are usually indicated by incorrect output readings from the system, error messages, or failed tests.

Consider all sources when identifying a problem in your system.

Symptom	Potential Cause	Corrective Action
Output at 0 mA.	No power to transmitter.	Check power source and connections to the transmitter.
	Analog output improperly configured.	Check the connections
	Electronics failure.	Replace the electronics boards
Output at 4mA	Min Flow Cutoff set too high	Configure the Min flow cutoff to a lower value or increase the flowrate above the min flow cut off value.
	Flow is in reverse direction	Enable Invert Flow Dir function
	Shorted coil	Check coil
	Empty pipe	Fill pipe
	Electronics failure	Replace the electronics boards
Pulse output at zero, regardless of flow	No power to transmitter	Check power source and connection to the transmitter
	Wrong wiring	Check pulse output wiring at digital output terminals. Refer to wiring diagram for pulse output
	Reverse flow	Enable Invert Flow Dir function
	Electronics failure	Replace the electronics boards
Reading doesn't appear to be within rated accuracy	Transmitter, control system, or other receiving device not configured properly	Check all configuration variables for the transmitter, flowpipe, communicator, and/or control system. Perform a loop test to check the integrity of the circuit
	Electrode Coating	Downsize flowtube to increase flowrate above 3 m/s. Periodically clean flowpipe
	Air in line	Move the flowpipe to another location in the process line to ensure that it is full under all conditions
	Flow rate is below 0.3 m/s (specification issue)	See accuracy requirement for specific transmitter and flowpipe
	The "Zero flow" calibration was not performed when the flowpipe is full, or flowrate is zero	Perform the "zero flow" function
	Empty pipe Error	Perform the full pipe and empty pipe calibration
	Coil Error	Check the coil connection
	Transmitter failure	Replace the electronics boards

In some circumstances, process conditions themselves can cause the meter output to be unstable. The basic procedure for addressing a noisy process situation is outlined below. Complete them in order. When the output attains the desired stability, no further steps are required:

1. Increase the Damping
2. Check the Ground connection

If the basic steps for troubleshooting are not sufficient contact our technical support.

Symptom	Potential Cause	Corrective Action
Noisy Process	Chemical additives upstream of magnetic flowmeter	Move injection point downstream of magnetic flowmeter.
	Sludge flows–Mining/Coal/Sand/Slurries (other slurries with hard particles)	Decrease flow rate.
	Styrofoam or other insulating particles in process	Consult factory
	Electrode coating	Downsize flowtube to increase flow rate. Periodically clean Sensor pipe.
	Air in line	Move the Sensor pipe to another location in the process line to ensure that it is full under all conditions
Meter output is unstable	Electrode incompatibility	Check the chemical compatibility with electrode material
	Improper grounding	Put pins 1 and 2 of the dip-switch on the electrical contact board in the OFF position. On the error page of the display only the message “COIL ERROR” should be displayed, if the message “EMPY PIPE” is also displayed, the grounding of the measuring point must be checked.
	High local magnetic or electric fields nearby	Move magnetic flowmeter far from the electromagnetic noise sources
	Sticky valve (look for periodic oscillation of meter output)	Correct valve sticking
	Analog output loop problem	Check that the 4–20 mA loop matches the digital value. Perform loop test







# 12-FACTORY TEST AND QUALITY CERTIFICATE



In conformity to the company and check procedures I certify that the equipment:

(Electromagnetic induction flow measurement)

is conform to the technical requirements on Technical Data and it is made in conformity to the procedure

Quality Control Manager: ..... Production and check date: .....



This mark on the instrument indicates that the product and its electronic accessories must not be disposed of with other household waste at the end of their useful life.

To avoid possible damage to the environment or human health resulting from uncontrolled waste disposal, please return the equipment directly to a specialized recycling company, in compliance with local regulations.

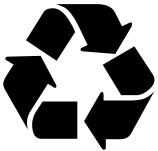

**NI - MH**

This instrument is powered by a battery type 2,4V triple-A, 0.6Ah NiMH; at the end of the life of the battery or the instrument, do not disperse it in the environment.

The battery must be disposed of in the appropriate collection centers.