

RBmag

Battery-powered electromagnetic flow meter

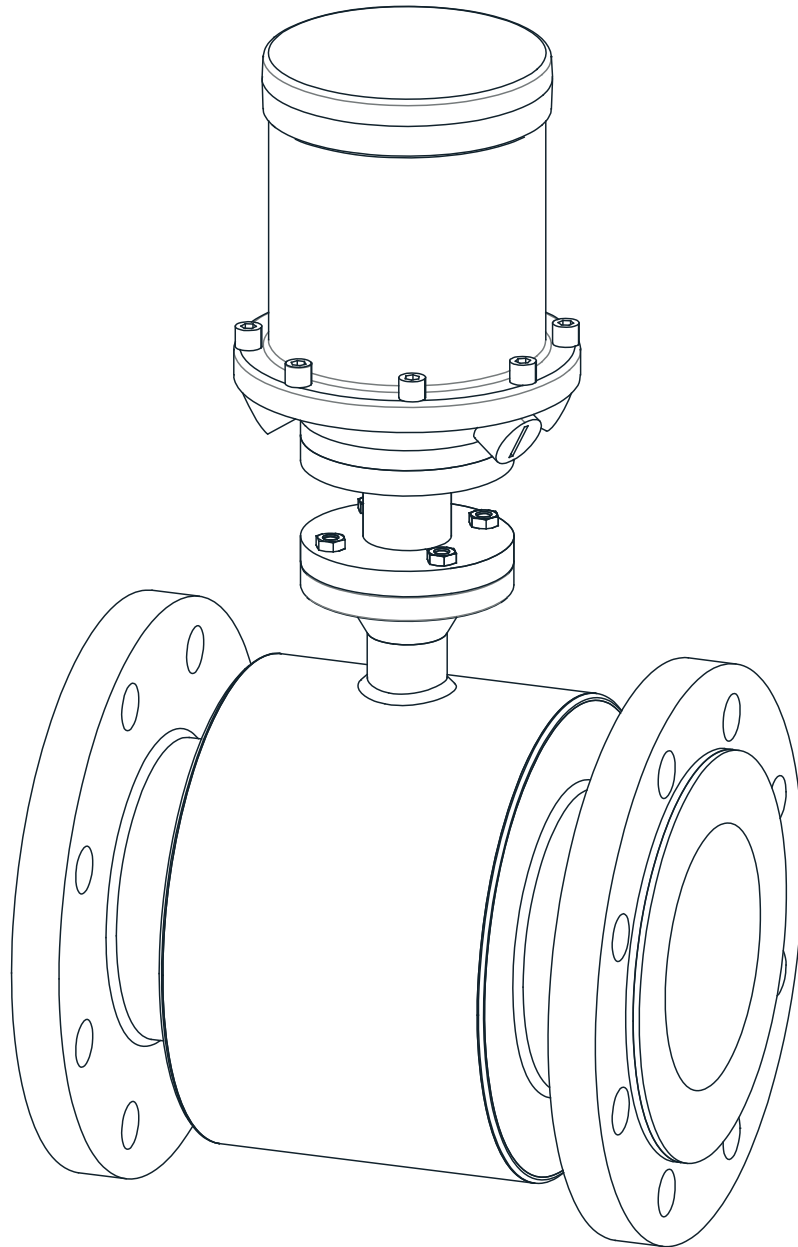

technical documentation EN rev. of 20/12/2022

INDEX

1-WARRANTY	page 3
2-CALIBRATION CERTIFICATE	page 3
3-PRODUCT	page 4
4-TECHNICAL SPECIFICATIONS	page 6
5-FLOW RANGE	page 7
6-DIMENSIONS	page 9
7-INSTALLATION	page 14
8-ELECTRICAL CONNECTIONS	page 22
9-LOCAL OPERATOR INTERFACE (LOI)	page 28
10-PROGRAMMING	page 29
11-TROUBLESHOOTING	page 45
12-TESTING AND QUALITY CERTIFICATE	page 48

1-WARRANTY

SGM LEKTRA SRL undertakes to remedy any defect, non-conformity or shortcoming that may occur within 12 months from the delivery date, provided that it is attributable to the company and has been notified within the established terms.

SGM LEKTRA SRL may choose whether to repair or replace the faulty Products.

The Products replaced under warranty will be covered by an additional 12-month warranty.

The Products repaired under warranty will have a warranty until the original time limit.

The parts of the Products repaired out of warranty will have a 3-month warranty.

The Products are only guaranteed to meet particular specifications, technical characteristics or conditions of use if this is expressly agreed in the Purchase Agreement or in the documents referred to therein.

The warranty of SGM-LEKTRA SRL absorbs and replaces the warranties and responsibilities, both contractual and non-contractual, originating from the supply such as, for example, compensation for damages, reimbursement of expenses, etc., both towards the Customer and towards third parties.

The warranty is void in the event of tampering with or improper use of the Products.

2-CALIBRATION CERTIFICATE

The magnets are all individually tested on 3-point calibration rigs.

SGM LEKTRA issues a document on letterhead that certifies the average error of the 3 calibration points.

The calibration document is supplied together with the unit itself.

SGM LEKTRA keeps a file of the test data of each magnet on the basis of which the relative certificate was issued.

The calibration rig is certified by the NIM (National Institute of Metrology), which is recognized by the international body BIPM (Bureau International des Poids et Metrologie), and complies with the NTC ISO IEC 17025 standards

3- PRODUCT

**COMPACT VERSION WITH
REMOTE ANTENNA**

- External antenna with a 3 m cable
- Integrated GPRS module
- Electromagnetic converter

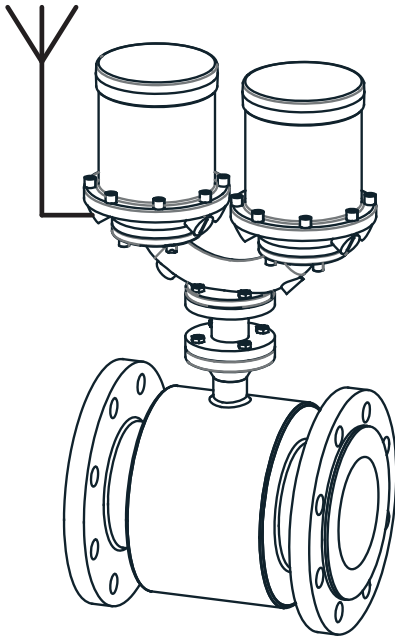

**COMPACT VERSION WITH
ANTENNA AND GPRS MODULE**

- Integrated antenna and GPRS module
- Electromagnetic converter

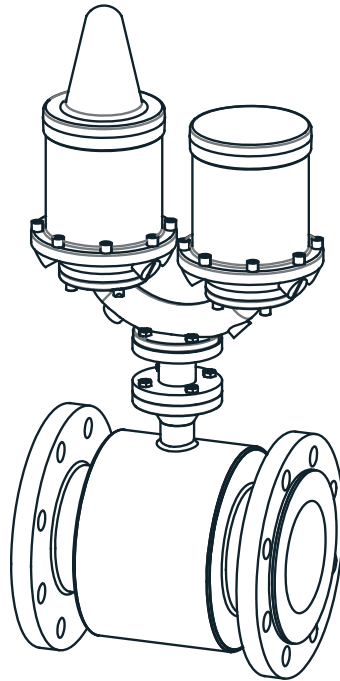

COMPACT VERSION

- Electromagnetic converter

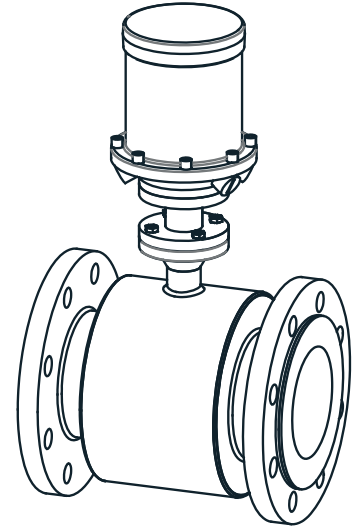

**SEPARATE VERSION WITH
REMOTE ANTENNA**

- External antenna with a 3 m cable
- Integrated GPRS module
- Electromagnetic converter
- Connection head
- Wall bracket

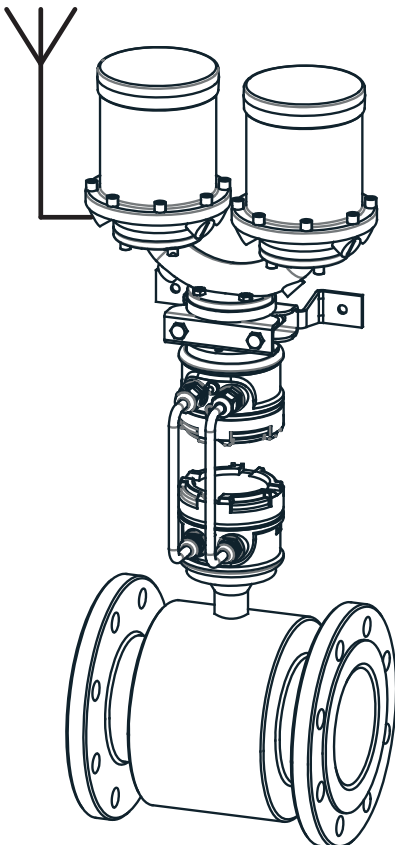

**SEPARATE VERSION WITH
ANTENNA AND GPRS MODULE**

- Integrated antenna and GPRS module
- Electromagnetic converter
- Connection head
- Wall bracket

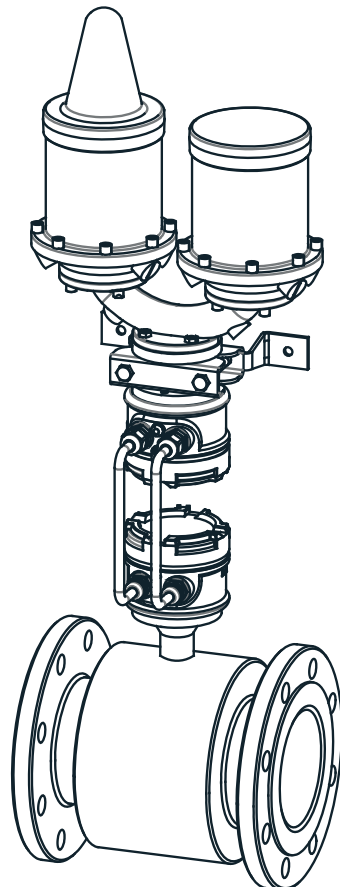

SEPARATE VERSION

- Electromagnetic converter
- Connection head
- Wall bracket

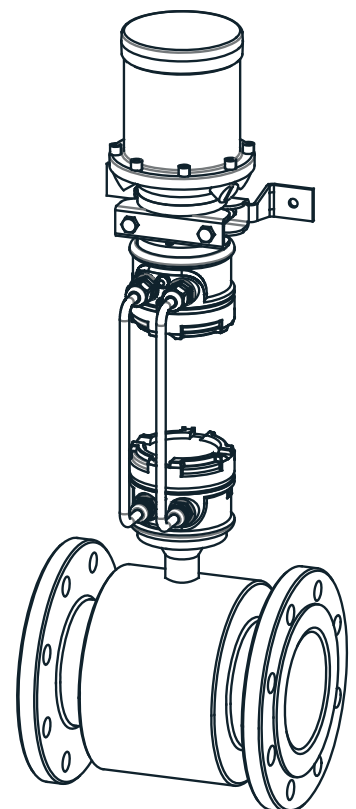

3.1 IDENTIFICATION

Every instrument has an adhesive identification plate on which the main information about the meter is outlined. The following image describes the information and data on the plate.

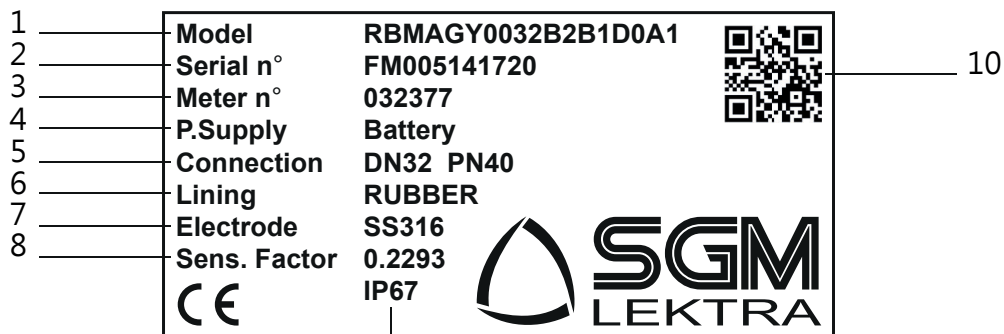

- 1. Product code
- 2. Serial number
- 3. Production lot
- 4. Supply voltage

- 5. Process connection
- 6. Coating material
- 7. Electrode material
- 8. Sensor coefficient

- 9. Protection rating
- 10. QR code, link to the product web page

4-4- TECHNICAL SPECIFICATIONS

Flow range

Processing of signals coming from fluids with speeds up to 10m/s in both directions (bidirectional meter).

Lining material / range size

PTFE DN10 ÷ DN500

RUBBER DN65 ÷ DN800

Sensor material

SS321

Electronic housing material

SS316 / ABS

Electrode material

SS316L - Hastelloy C - Titanium - Tantalum - Platinum

Measurement range

<0,1m³/h ÷ >18000m³/h

Accuracy

±0,5%

Repeatability

±0,1%

Fluid conductivity

The fluid must have a conductivity of at least 20 micro Siemens

Power supply voltage

Battery life: 6 years

Sensor tube temperature range

Remote version process temperature: rubber -10 ÷ + 80 °C; PTFE -40 ÷ + 150 °C

Compact version process temperature: rubber -10 ÷ + 80 °C; PTFE -40 ÷ + 100 °C

Storage temperature: -40 + 85 °C

Converter temperature range

-20÷50°C

Communication protocol

Modbus (opz.)

Output signals

Pulse: open collector

Analog: 4÷20mA

Reverse flow

Instantaneous measurement and totalisation of the reverse flow.

Output test

Frequency output: the transmitter can force the output signal from 0.1 to 5000 Hz at a test value.

Start time

0.5 s from zero flow.

Flow cutoff

Adjustable 0.0 ÷ 9.9% of Q_{max}. Below the set value, the instantaneous flow is displayed and the outputs are forced to zero.

Relative humidity

☒ 95%

Response time (integration)

Adjustable between 0.1 and 99 seconds

Compact version protection

IP68

Remote version protection

IP67 / IP68 for the sensor (on request) - IP68 for the converter

5-FLOW RANGE

5.1 FLOW RANGE GRAPH

Flows from DN3 to DN500 (standard min.DN10)

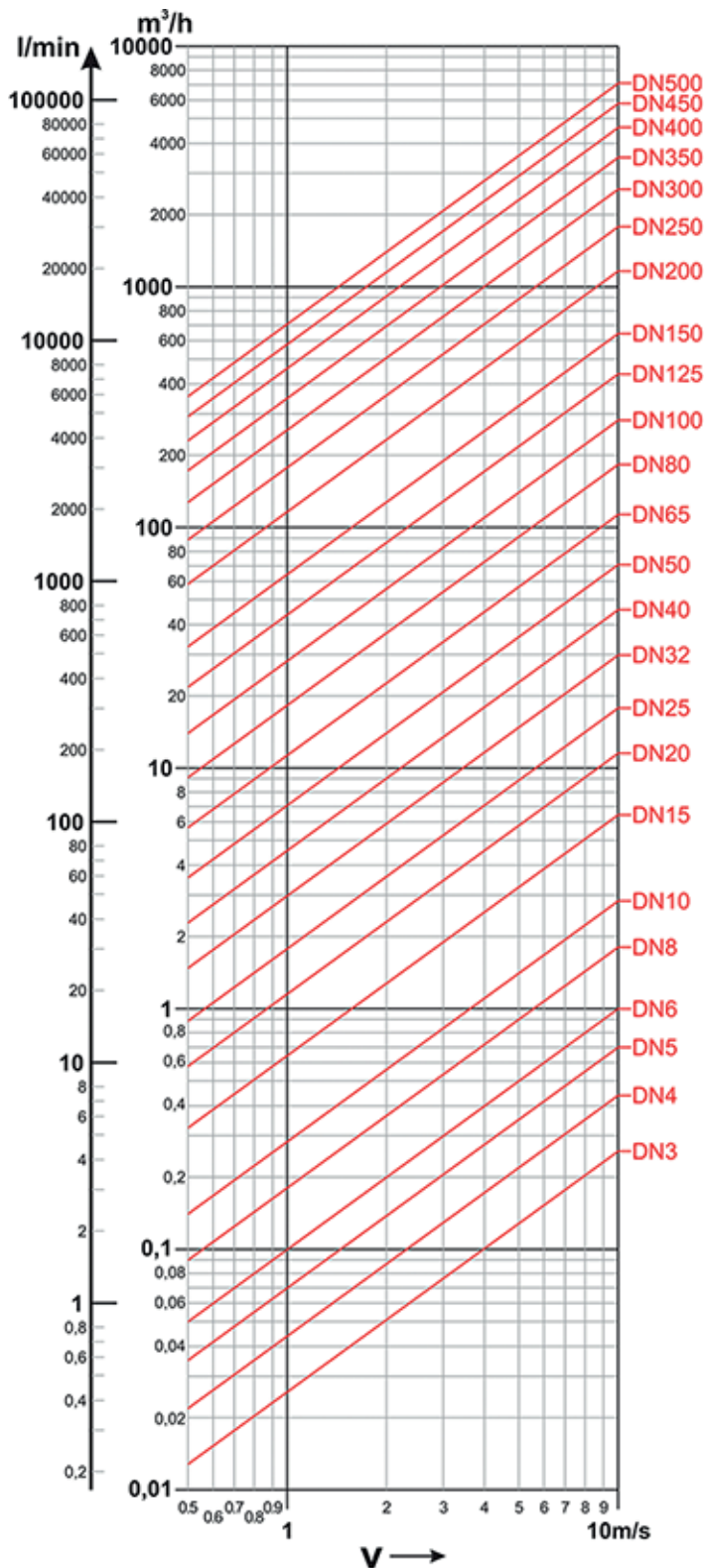

Flows from DN600 to DN2000

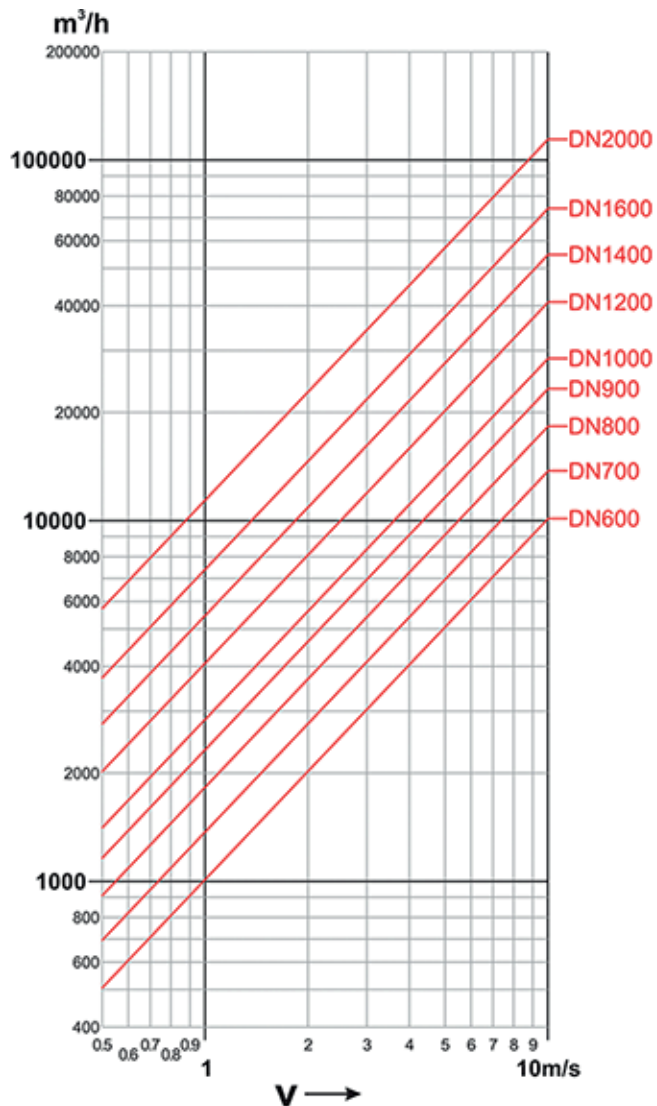

5.2 FLOW RANGE TABLE

Flow range table DN10 ÷ 300	
DN (mm)	Minimum (0.5m / s) maximum (10m / s) range
10	0.14 ÷ 2.9 m3/h
15	0.3 ÷ 6 m3/h
20	0.5 ÷ 12 m3/h
25	0.6 ÷ 18 m3/h
32	1 ÷ 30 m3/h
40	1.8 ÷ 42 m3/h
50	3 ÷ 66 m3/h
65	5.8 ÷ 120 m3/h
80	8.9 ÷ 180 m3/h
100	11 ÷ 282 m3/h
125	20 ÷ 450 m3/h
150	30 ÷ 600 m3/h
200	50 ÷ 1100 m3/h
250	85 ÷ 1700 m3/h
300	110 ÷ 2400 m3/h

Flow Range Table DN350 ÷ 2000	
DN (mm)	Minimum (0.5m / s) maximum (10m / s) range
350	180 ÷ 3300 m3/h
400	220 ÷ 4200 m3/h
450	270 ÷ 5400 m3/h
500	320 ÷ 6600 m3/h
600	490 ÷ 9600 m3/h
700	680 ÷ 13500 m3/h
800	900 ÷ 18000 m3/h

5.3 HEAD LOSS

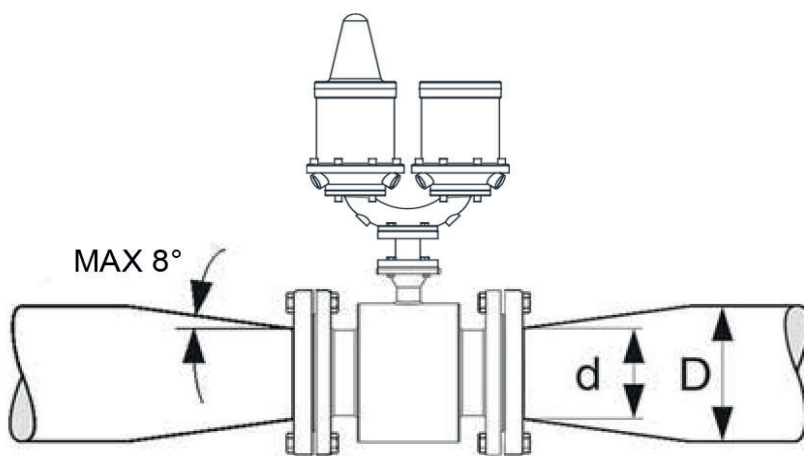

Adaptation cones

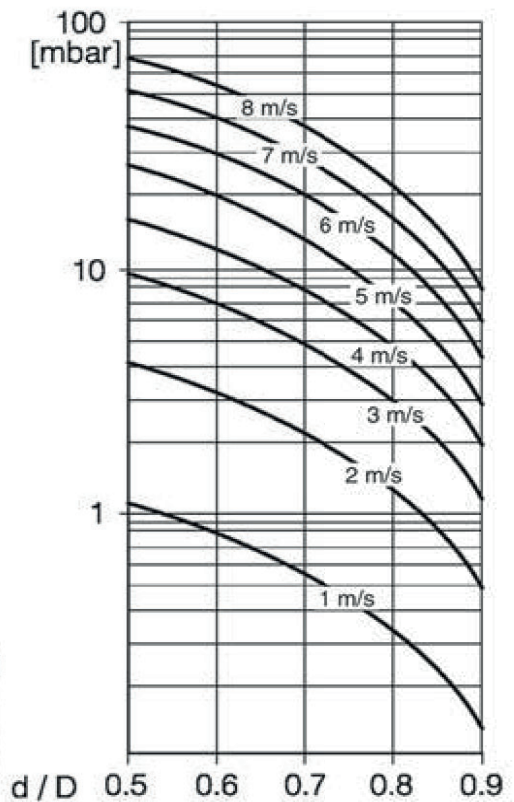

6-DIMENSIONS

6.1 REMOTE VERSION CONVERTER - WALL MOUNTING

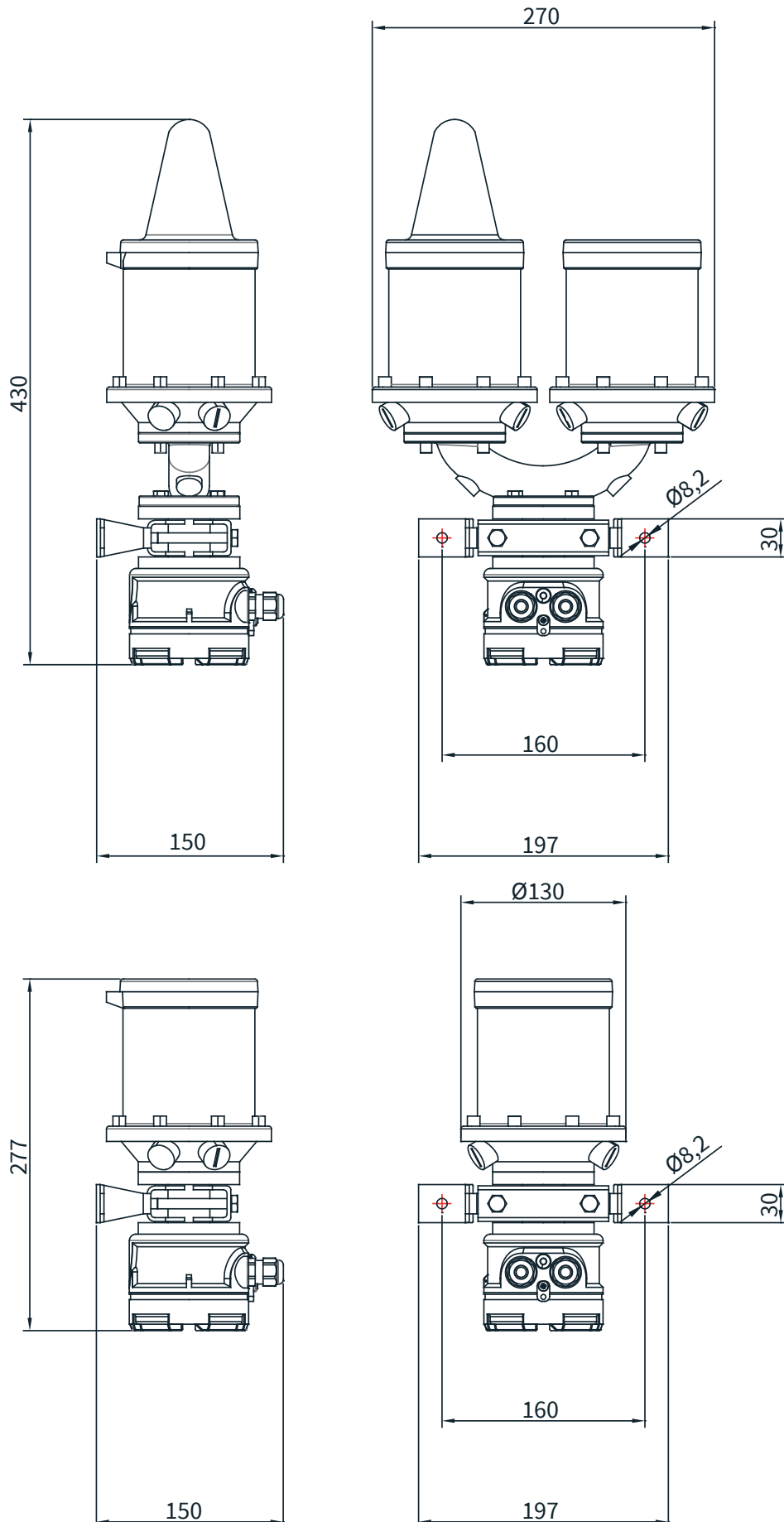

6.2 COMPACT VERSION DN10 ÷ DN80 PN16 - PN40

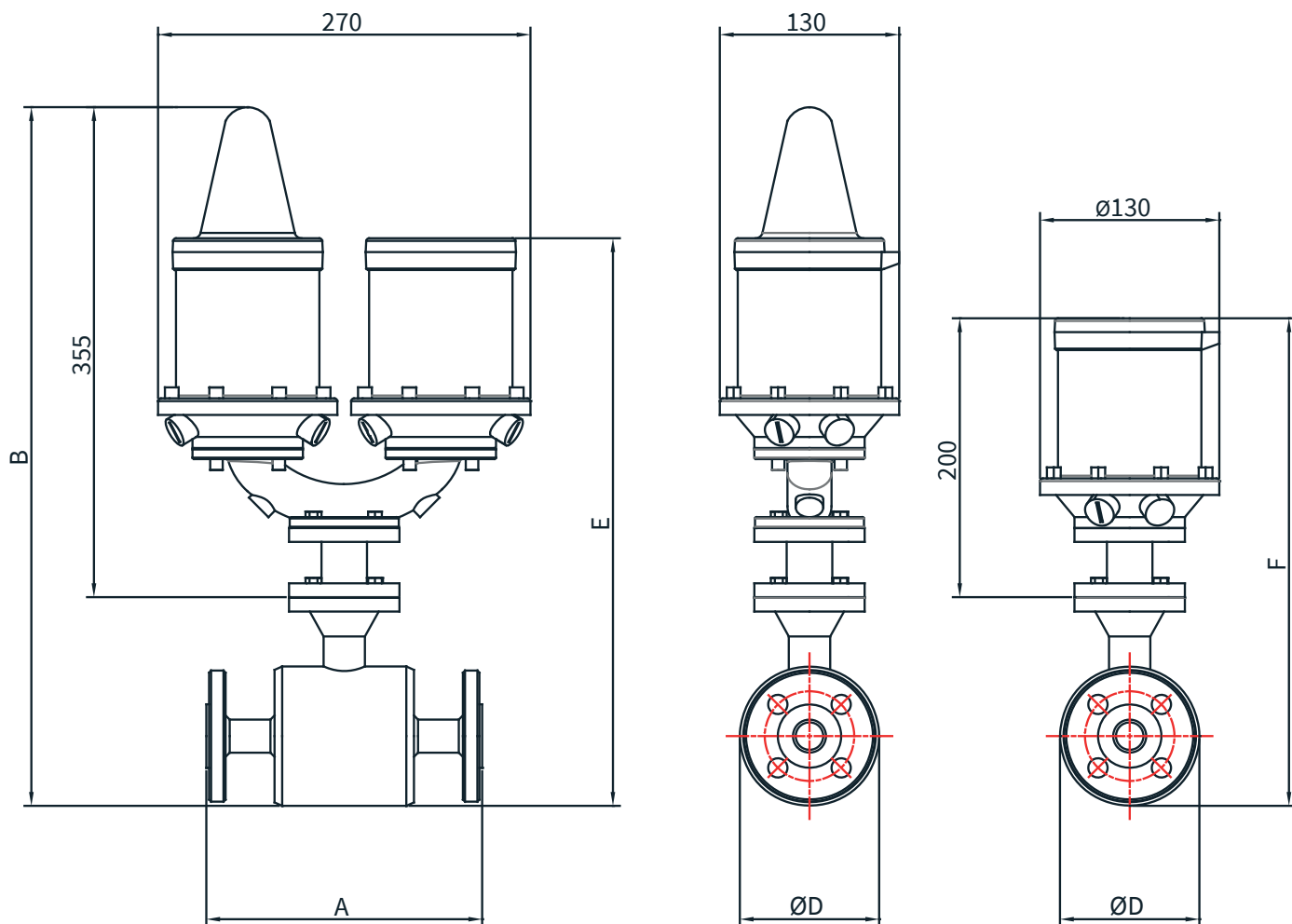

DN (mm)	A (mm)	PN 16 - PN 40			
		B (mm)	E (mm)	F (mm)	ØD (mm)
10	200	415	320	260	90
15		415	320	260	95
20		420	325	265	105
25		420	325	265	115
32		535	440	380	140
40		555	460	400	150
50		560	465	405	165
65		580	485	425	185
80		595	500	440	200

6.3 COMPACT VERSION DN100 ÷ DN1000 PN10 - PN16 - PN40

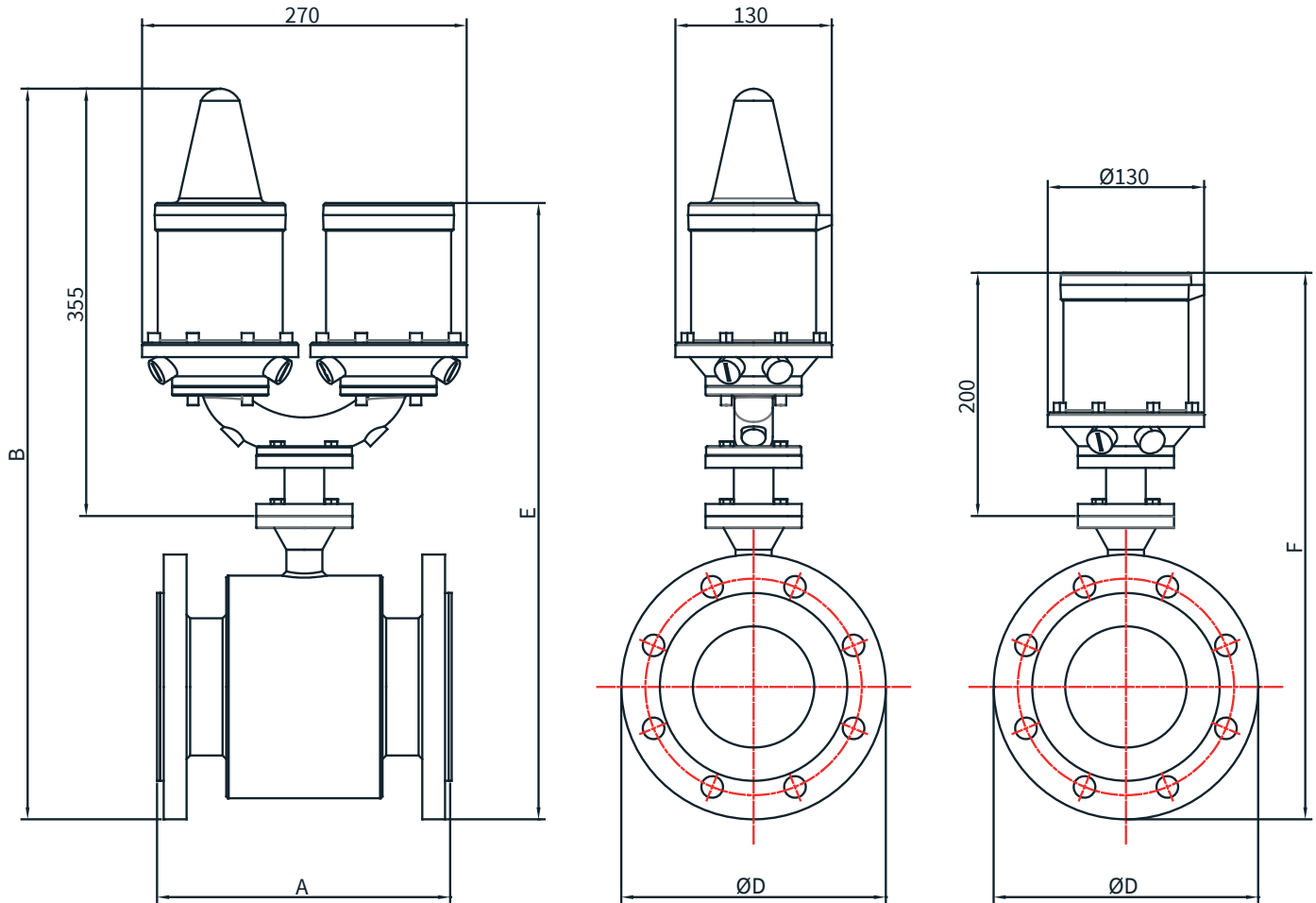

DN (mm)	A (mm)	PN 10				PN 16				PN 40			
		B (mm)	E (mm)	F (mm)	ØD (mm)	B (mm)	E (mm)	F (mm)	ØD (mm)	B (mm)	E (mm)	F (mm)	ØD (mm)
100	250	-	-	-	-	620	525	465	220	630	535	445	235
125	250	-	-	-	-	640	545	485	250	655	560	500	270
150	300	-	-	-	-	680	585	525	285	690	595	535	300
200	350	740	645	585	340	740	645	585	340	760	665	605	375
250	450	790	695	635	395	795	700	640	405	820	725	665	450
300	500	840	745	685	445	840	745	685	460	870	775	715	515
350	550	890	795	735	505	900	805	745	520	930	835	775	580
400	600	950	855	795	565	960	865	805	580	1000	905	845	660
450	600	1000	905	845	615	1015	920	860	640	1040	945	885	685
500	600	1050	955	895	670	1070	975	915	715	1090	995	935	755
600	600	1150	1055	995	780	1180	1085	1025	840	2005	1910	1850	890
700	700	1270	1175	1115	895	1300	1205	1145	910	-	-	-	-
800	800	1385	1290	1230	1015	1390	1295	1235	1025	-	-	-	-

6.4 REMOTE VERSION DN10 ÷ DN25 PN16 - PN40

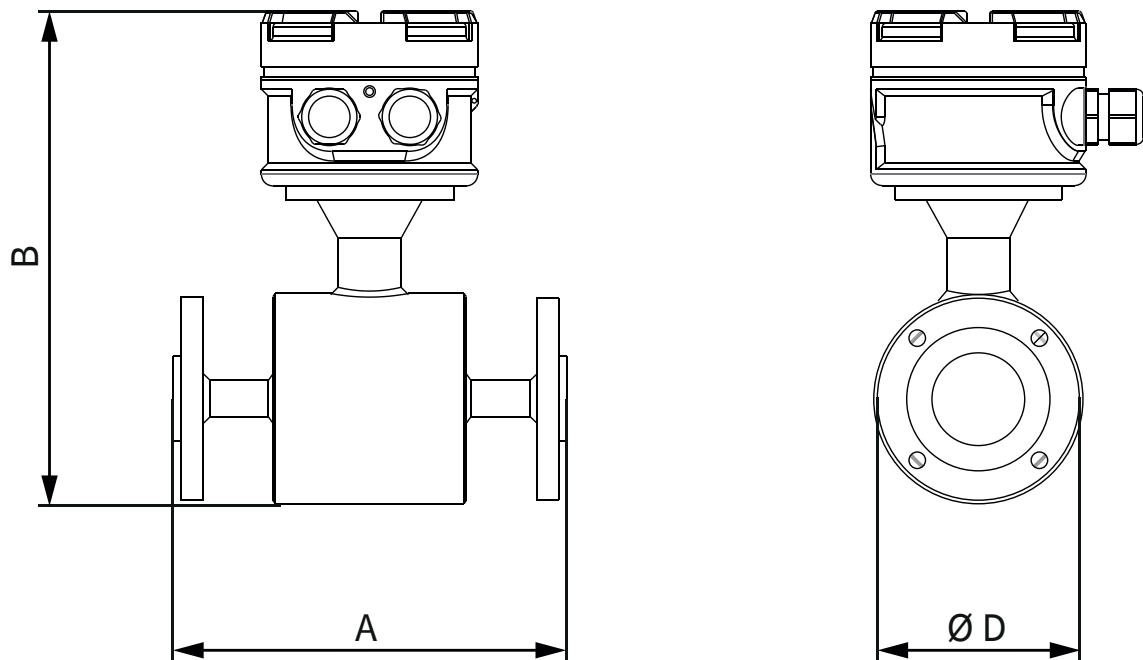

DN (mm)	A (mm)	PN 16 - PN 40	
		B (mm)	ØD (mm)
10	200	235	90
15		235	95
20		240	105
25		240	115

6.5 REMOTE VERSION DN100 ÷ DN1000 PN10 - PN16 - PN40

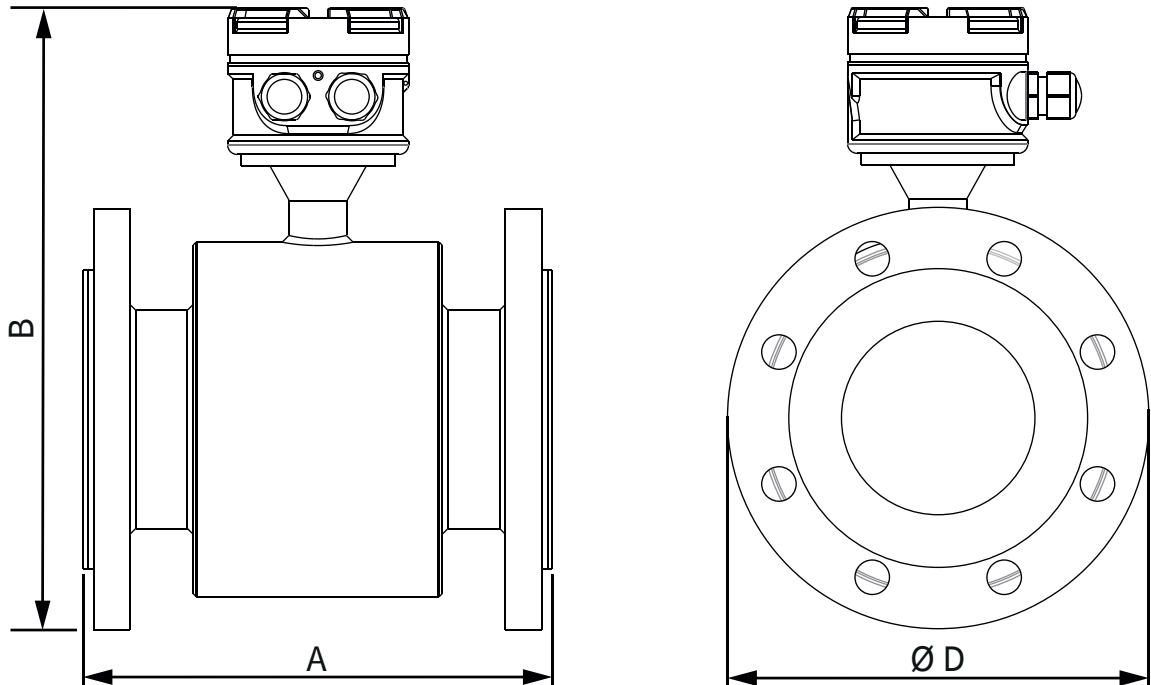

DN (mm)	A (mm)	PN 10		PN 16		PN 40	
		B (mm)	ØD (mm)	B (mm)	ØD (mm)	B (mm)	ØD (mm)
32	200	-	-	251	140	254	140
40	200	-	-	270	150	270	150
50	200	-	-	280	165	280	165
65	200	-	-	298	185	298	185
80	200	-	-	315	200	315	200
100	250	-	-	333	220	343	235
125	250	-	-	358	250	368	270
150	300	-	-	393	285	400	300
200	350	450	340	450	340	468	375
250	450	505	395	510	405	533	450
300	500	550	445	558	460	586	515
350	550	605	505	613	520	643	580
400	600	665	565	673	580	713	660
450	600	715	615	728	640	751	685
500	600	765	670	785	715	805	755
600	600	870	780	900	840	810	890
700	700	987	895	995	910	-	-
800	800	1100	1015	1105	1025	-	-

7-INSTALLATION

This section covers the procedures for installing the RBmag magnetic flow meter.

7.1 SAFETY MESSAGES

Instructions and procedures in this section may require special precautions to ensure the safety of the personnel carrying out the operations. Safety information will be highlighted by the warning symbol.

Refer to the following safety guidelines before performing an operation preceded by this symbol 

7.2 WARNINGS

7.2.1 Explosions may cause death or serious injury

- Check that the installation and operation area comply with the characteristics of the sensor tube and the transmitter.
- Do not open the transmitter in explosive atmospheres when the power supply is switched on.

7.2.2 Failure to follow safe installation and maintenance guidelines can result in death or serious injury

- The installation must be carried out only and exclusively by skilled personnel.
- Do not perform any operations other than those described in this manual.

7.3 PREPARATION FOR INSTALLATION

There are several preparation steps that make the installation process easier.

They include identifying the options and configurations that apply to your application, setting switches if necessary, and considering mechanical, electrical, and environmental requirements.

We remind you that the inner lining of the measuring tube can be damaged if handled incorrectly.

Do not place any objects inside the measuring tube in order to lift or leverage.

Any damage to the inner lining of the measuring tube can make the latter unusable.

7.3.1 Options and configurations

Standard functions of the RBmag include checking the measuring tube coils and of one or more of the following configurations or options:

- Analogical output
- Pulse output
- MMODBUS RTU output

Be sure to correctly identify the options and configurations relevant to your application, and prepare a list to be used during the installation and configuration procedure.

7.3.2 Mechanical considerations

The installation point of the RBmag should be spacious enough to allow safe mounting: full opening of the lid for easy access to connections and good readability of the display.

The display and the converter can be rotated by 90°: this must be done before installing the RBmag.

7.3.3 Lifting instructions

The flow meter must be lifted using a suitable lifter, as shown in the figure below.

This must be suitable for the load to be lifted to ensure adequate safety.

Do not lift the flow meter using ropes tied between the sensor and the transmitter (compact version) or the electrical connection box (remote version).

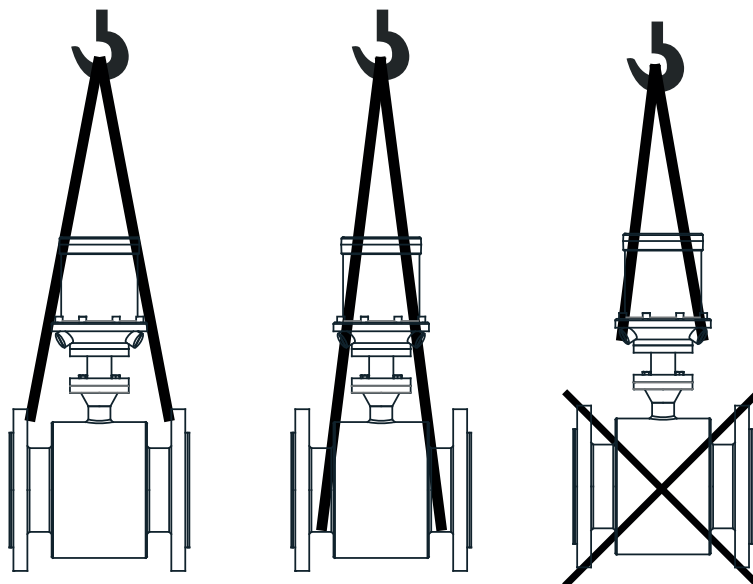

7.4 GENERAL INSTALLATION CRITERIA

The direct direction is set in the factory and is marked on the instrument by an arrow; where possible, the meter should be installed so that the flow direction is the same as the one shown on the plate.

If this is not possible, just reverse the direction of the direct flow using the “Flow Direction” parameter.

In order to guarantee the accuracy of the measurement, the straight pipe upstream of the instrument must be at least 5 times longer than the diameter DN of the measuring tube: this is because when the distance between the instrument and the valves, or restrictions or other, is greater than 5 times the DN diameter of the pipe, their influence is negligible.

The length of the straight tube downstream of the sensor must be greater than 3 times the DN diameter of the pipe.

7.5 INSTALLATION POSITION

The installation can be horizontal or vertical, as long as you ensure that there is no deposit of material on the electrodes or air bubbles (especially in case of horizontal installation).

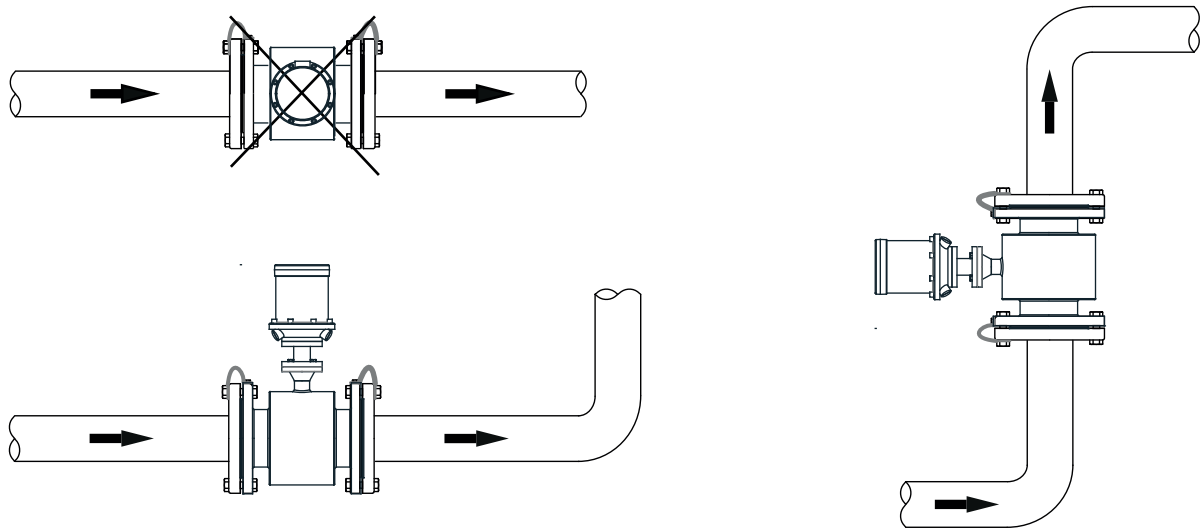

Installation in horizontal or vertical pipe

The instrument must be installed in a straight section of pipe to normalize the flow if there are elbow bends, flow regulators, valves, etc. in the vicinity.

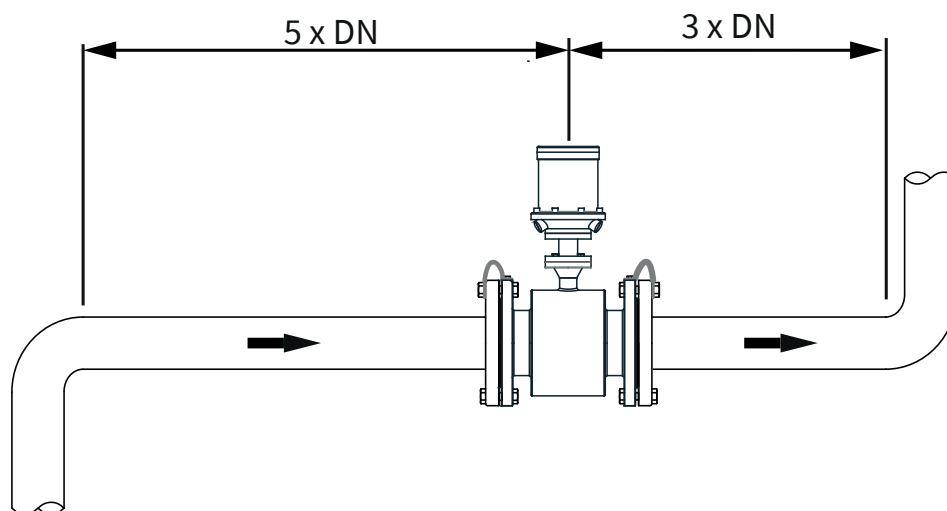

Minimum requirements for installation on straight pipe

The electromagnetic meter must be installed so that the pipe is always completely filled with fluid. In case of a partially full pipe, the meter must be installed according to the siphon phenomenon, that is, always keeping the section where the meter is installed full.

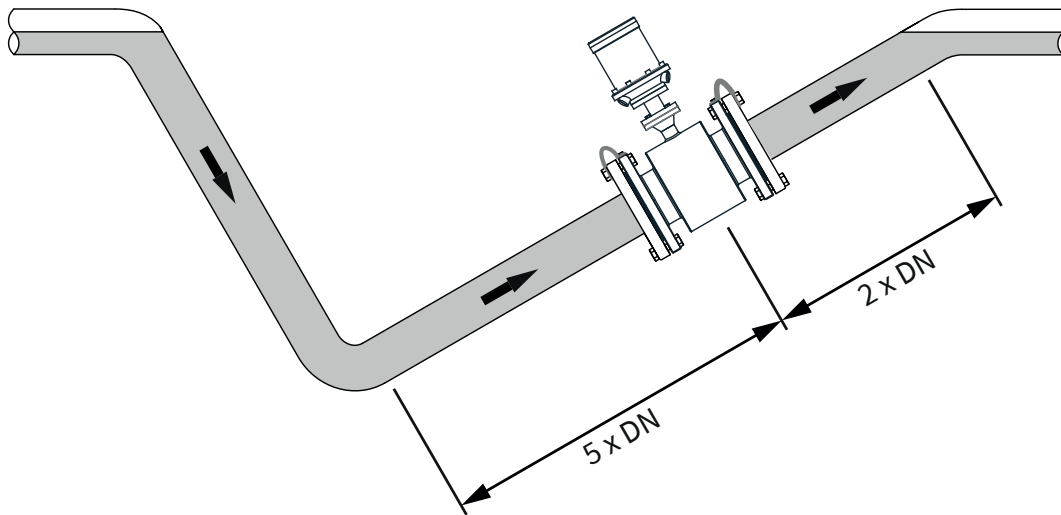

Installation in partially full pipe

The installation cannot be carried out in a section of pipe that might be emptied. For correct installation, therefore, check that the pipe is always full.

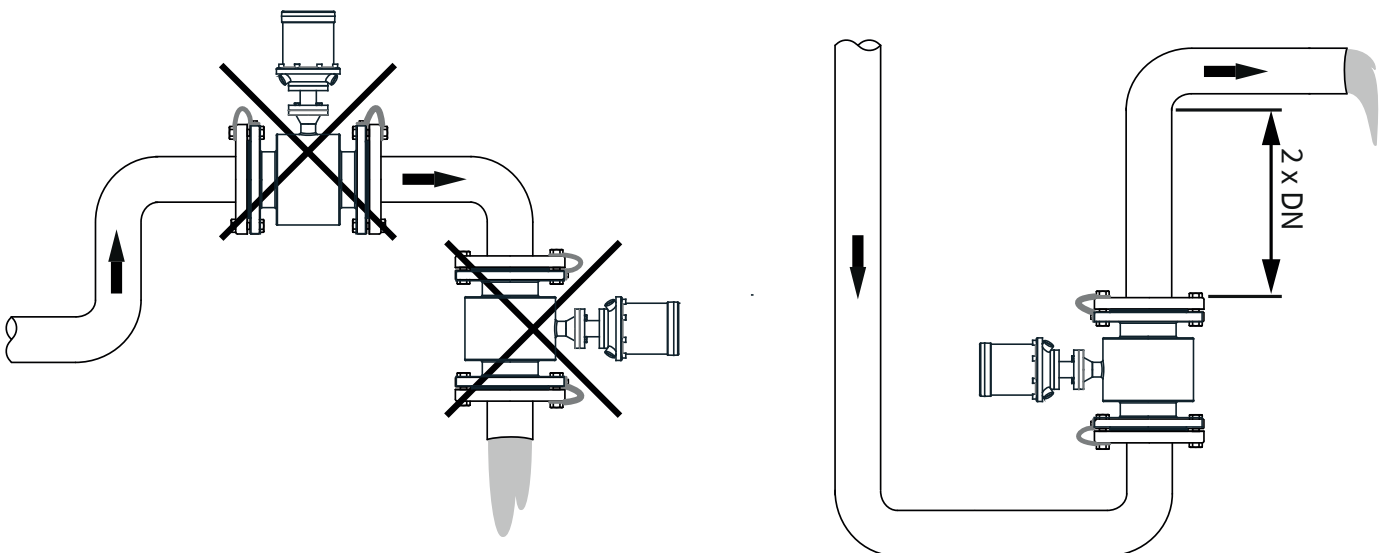

Pipe installation without emptying

The electromagnetic flow meter cannot be installed at the highest point of the pipeline, as air or gas can accumulate in the measuring tube.

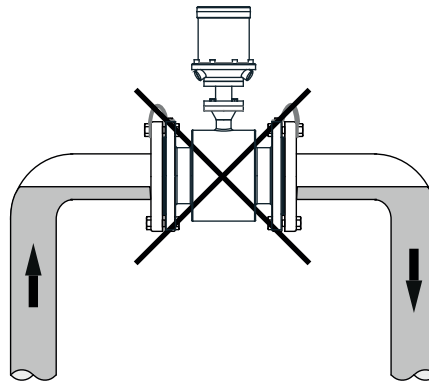

Installation at the top of the pipeline.

The electromagnetic flow meter cannot be installed upstream of a pump to avoid cavitation phenomena, which may damage the coating of the sensor.

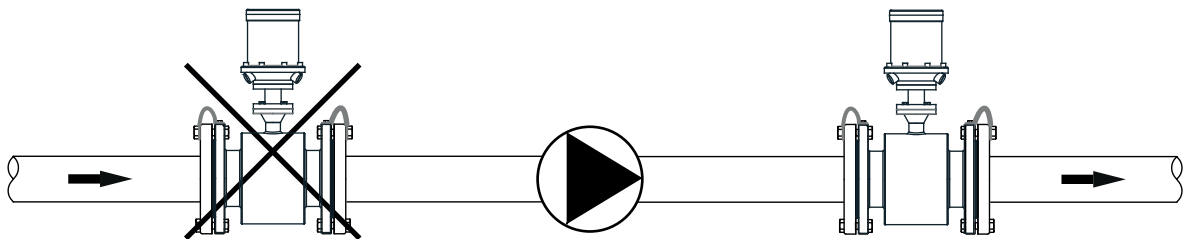

Installation near a pump.

In the presence of a downward section of pipe longer than 5 m, a siphon (a) with a relief valve (b) must be installed to avoid low pressure phenomena, which may damage the coating of the sensor.

ATTENTION: all phenomena that generate a strong depression inside the pipe can irreparably damage the insulating coating of the sensor tube itself.

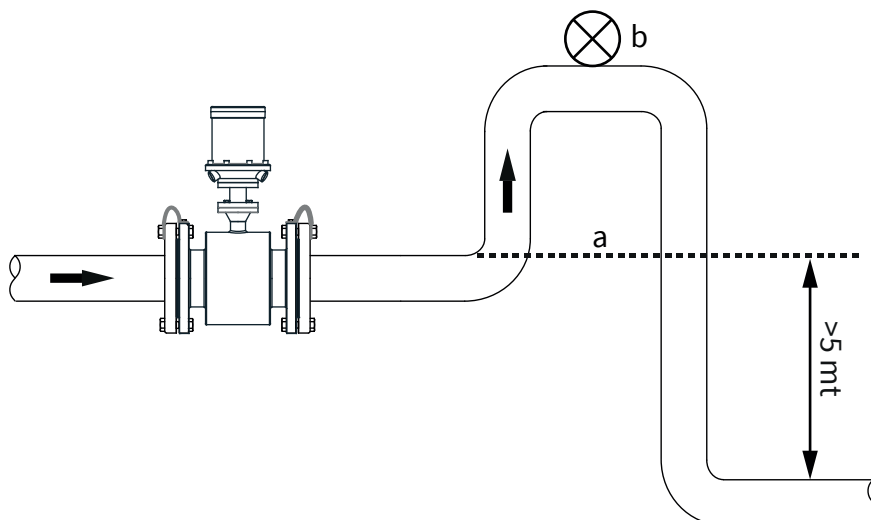

Installation near a downward stretch > 5 m

7.6 PRECAUTIONS FOR INSTALLATION

Adequate covering must be provided to prevent the instrument from being directly exposed to sunlight and rain and adverse weather conditions. The electromagnetic flow meter must not be subjected to excessive vibrations, strong temperature changes and long stays under jets of water. It must be protected against corrosive liquids.

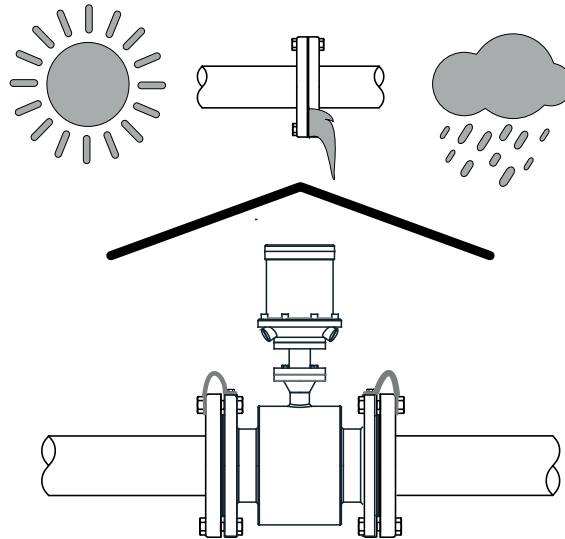

7.7 CONNECTION TO THE PIPES

The sensor itself cannot self-support and must be supported by the pipes to which it is connected. The sensor should not be subjected to great mechanical stress. Adequate measures, as in the examples shown below, must be taken to eliminate the stress due to thermal expansion.

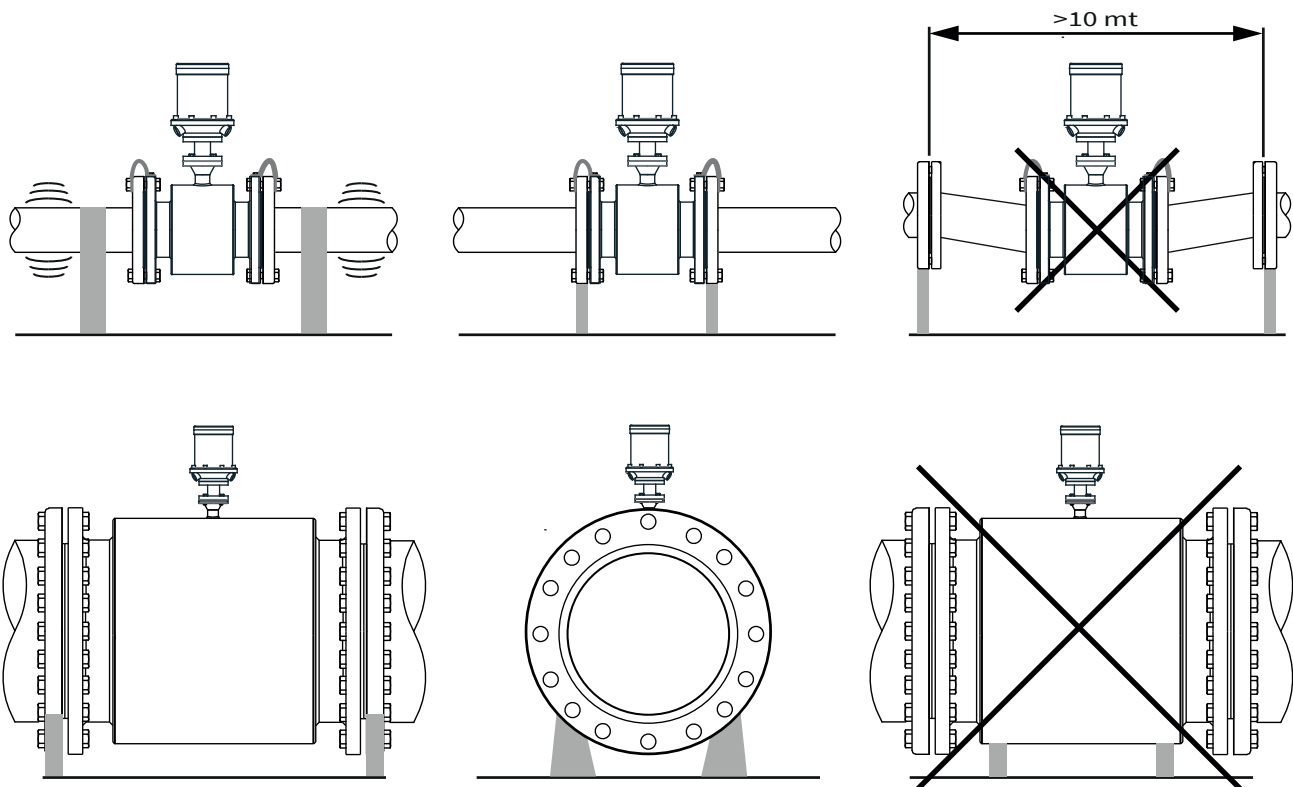

7.8 INSTALLATION REQUIREMENTS

- a) The measuring tube must be in line with the pipe through which the fluid flows.
For sensors below DN50, the centre-to-centre distance difference must be less than 1.5 mm; for sensors from DN65 to DN300, the difference must be less than 2 mm; for sensors from DN350 upwards, the centre-to-centre distance difference must be less than 4 mm.
- b) The seal between the flanges must be corrosion-resistant and must not extend into the pipe.
- c) The threads of the fastening screws and nuts must be in good condition. The screws must be tightened using a special wrench to ensure adequate tightening, the torque of which will depend on the size of the flanges.
- d) Particular precautions must be taken to prevent the coating of the measuring tube from heating up: this may be caused by the effect of welding on the pipe or by the use of the blowtorch to cut the pipe.
If the sensor is to be installed in a well or immersed in water, the sensor's electrical connection box must be sealed with a suitable resin (IP68 version).

7.9 ACCESSORIES

7.9.1 Grounding rings, optional

Material: SS 316L or Hastelloy C

Thickness: 2 mm

For non-conductive pipes, this type of accessory must be installed between the sensor flanges and the non-conductive pipe. To make the meter equipotential with the fluid, the grounding rings must be in direct contact with the fluid to be measured.

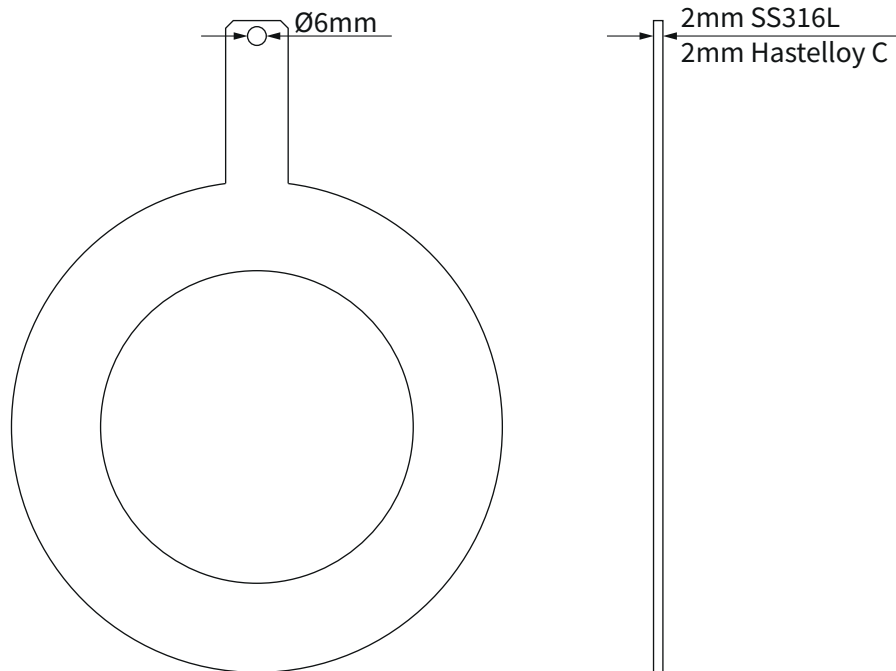

Grounding ring

7.10 EQUIPOTENTIALITY AND REDUCTION OF ELECTRICAL INTERFERENCES

The measuring circuit considers the fluid to be measured as being equipotential. In most metal pipe applications, the measured fluid is equipotential with respect to the grounding system of the plant. Since the coating isolates the sensor tube from the fluid, it is important to connect the grounding cables to the flanges of the connection tubes to make the fluid entering and leaving the sensor equipotential.

The grounding resistance should be less than 10 ohm.

In most applications, special precautions for the installation of the sensor are pretty pointless.

If you find yourself having the sensor installed on a pipe with cathodic protection, or in an electrolysis process, all the following precautions must be taken to prevent the current from flowing through the fluid in the sensor tube.

The following measures must be taken in order to ensure a reduction in the influence of the magnetic field:

- a) In conductive pipes, the instrument is made equipotential through the connection between the sensor and the adjacent pipe. The flange connection screws cannot be used as equipotential connection for the system; a cable must be used instead, as illustrated.

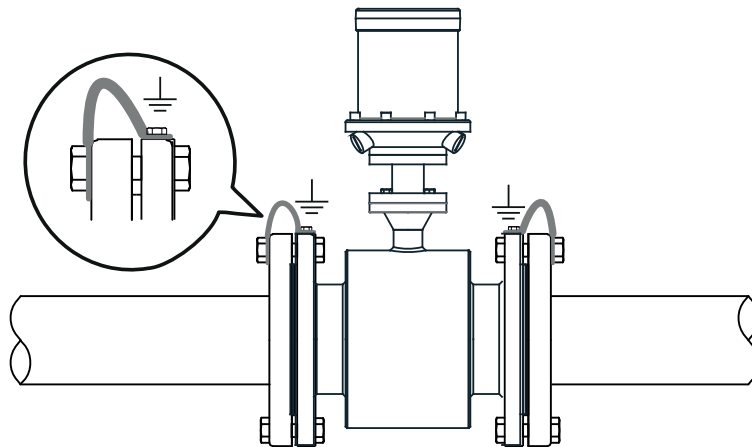

Equipotentiality of the sensor

- b) Non-conductive pipes require a sensor tube with the third electrode, or the installation of grounding rings. Such rings are inserted between the flange of the pipe and the flange of the sensor, both upstream and downstream, making sure that the grounding rings are in direct contact with the fluid and that they are connected to the external ground connection of the sensor tube by means of a suitable cable. N.B.: The use of grounding rings is recommended in applications with dark or waste water or similar.

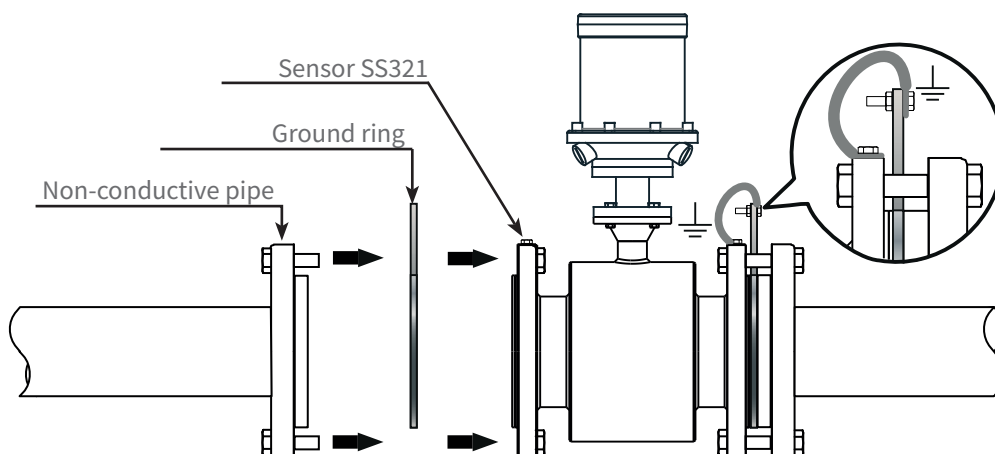

Grounding with non-conductive pipes

- c) Some systems, such as pipes with cathodic protection, may be affected by disturbance potentials as not all the line is equipotential with the grounding system. In order to eliminate this type of interference, we recommend disconnecting the line with two rubber hoses, as illustrated.

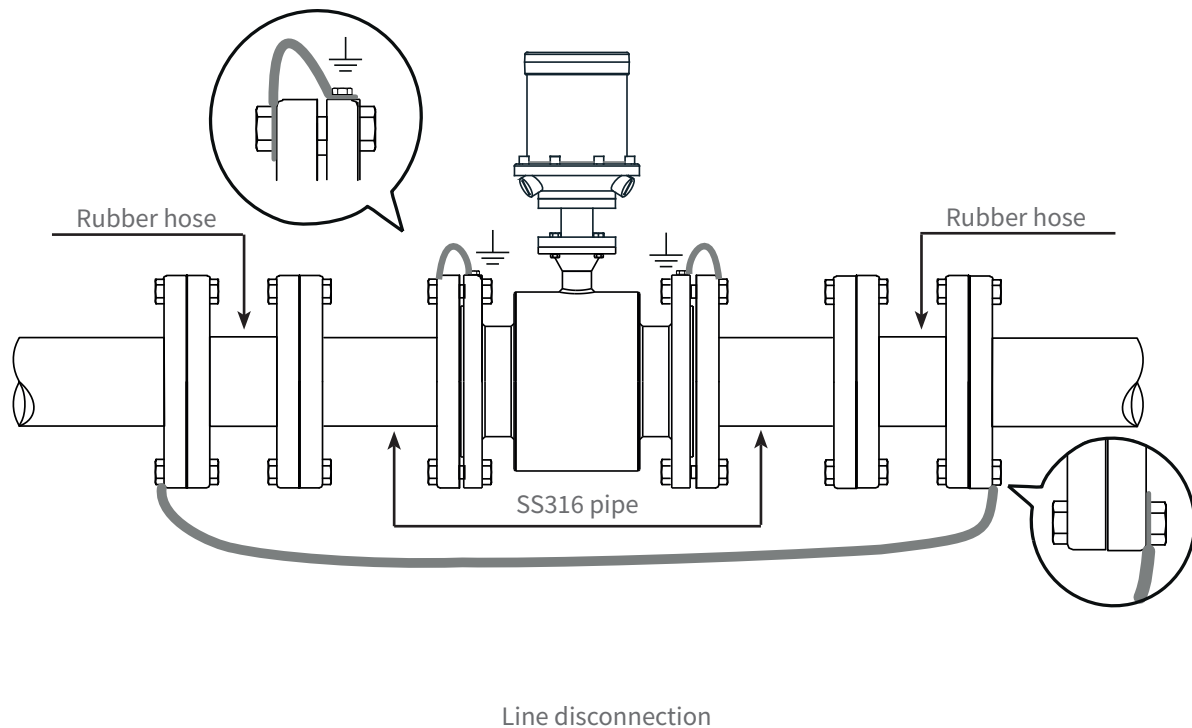

7.11 PREPARATION FOR COMMISSIONING

Check the installation and wiring carefully before putting it into operation!

It should be emphasized that the instrument is calibrated with an effective flow, and controlled within a framework of rigorous measures. All units sold are certified. No calibration is required when commissioning.

Follow the contents of this manual to check and analyze any malfunctions. It is forbidden to carry out operations at random that could change for the worse, or damage, the instrument.

Follow the steps below to put the instrument into operation.

- 1) First, open the valves upstream and downstream of the instrument to allow the sensor to be completely filled with product.
- 2) Turn on the meter. After one minute, the value displayed by the indicator reaches a certain number, which indicates that the cable connections are correct. If the direction of the flow is wrong, change the direction of the flow on the converter, by means of the "positive point" parameter.
- 3) Correct the Zero if necessary. Close the upstream and downstream sealing valve and let the product stop. The displayed value is 0. If the value displayed by the converter is higher or lower than 0, it could still be correct: first make sure that there are no leaks.

7.12 MAINTENANCE

In general, the magnetic flow meter does not need electrical maintenance. If the product adheres to the internal wall of the sensor, and to its electrodes, it is necessary to periodically carry out cleaning operations.

Be careful not to damage the coating and electrodes.

8-ELECTRICAL CONNECTIONS

8.1 CABLES INPUT

The remote version sensor pipe includes No. 2 M16x1.5 cable glands for connection to the converter.

8.2 PREVENTING INFILTRATIONS AND HUMIDITY

To avoid the infiltration of humidity inside the converter and the sensor, it is recommended:

- to fully and carefully tighten the covers and cable glands;
- to position the cables, as shown in the figure below, so that they form a downward curve at the outlet of the M16x1.5 cable gland; in this way, the condensate and / or rainwater will tend to drip from the bottom of the curve.

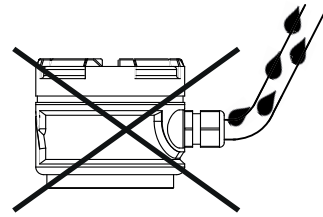
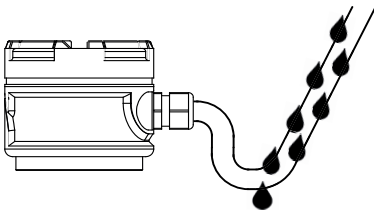

8.3 OUTPUTS

A watertight connector is available to connect the digital, analogue and serial output RS485.

8.3.1 Digital output

To enable the digital output, refer to paragraph 10.5.3 OUTPUT PARAMETER of this manual.

The digital output generates an output signal with respect to the increase of the total volume.

The signal is normally used in combination with an external totalizer, an impulse counter or an acquisition system.

The circuit resistance must be equal to or higher than 100K ohm

Follow the procedure illustrated here below to connect the signal cable to the transmitter:

1) Connect the two wires to wires F+ and F-

N.B. - Keep in mind that when the acquisition system, connected to the pulse output of the RBmag, supplies voltage to the circuit (MAX 24VDC), the transistor can switch up to 5mA at output.

It is therefore necessary to suitably size the manifold's resistor For example, if the system supplies a 24 VDC voltage, the manifold's resistor (PULL-UP) must be equal to or higher than 5K ohm.

The image below shows the connection diagram between the flow meter RBMAG and the pulse counter Mod. 199-B1X.

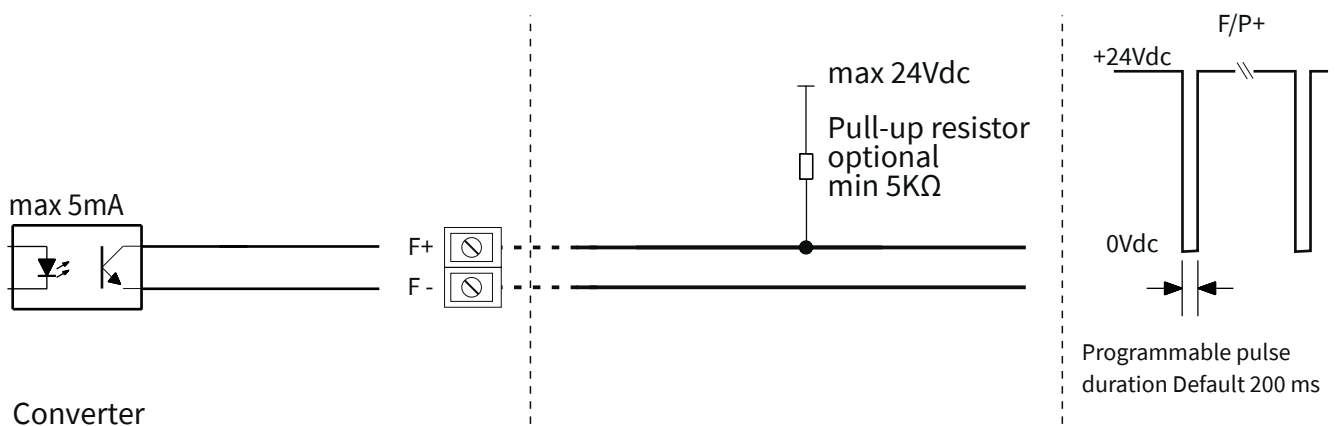
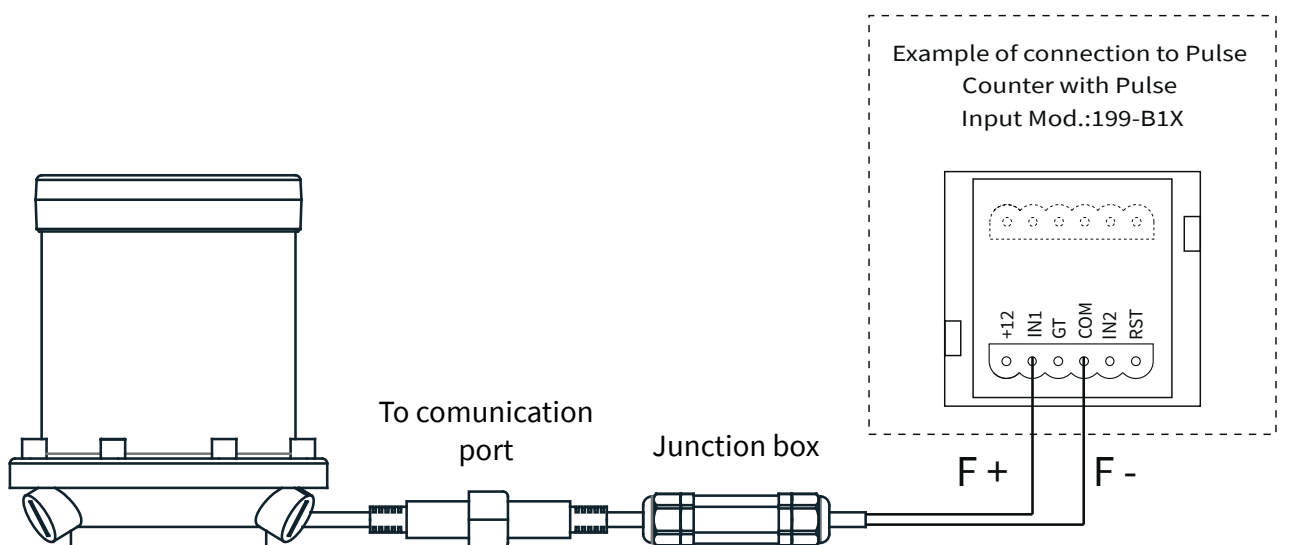

8.3.2 Serial output RS485

In the suitably arranged models, it is possible to communicate via MODBUS. Connect the serial cable to terminals A+ and B-. The diagram below shows the connection diagram between the RBMAG flow meter and, for example, a notebook.

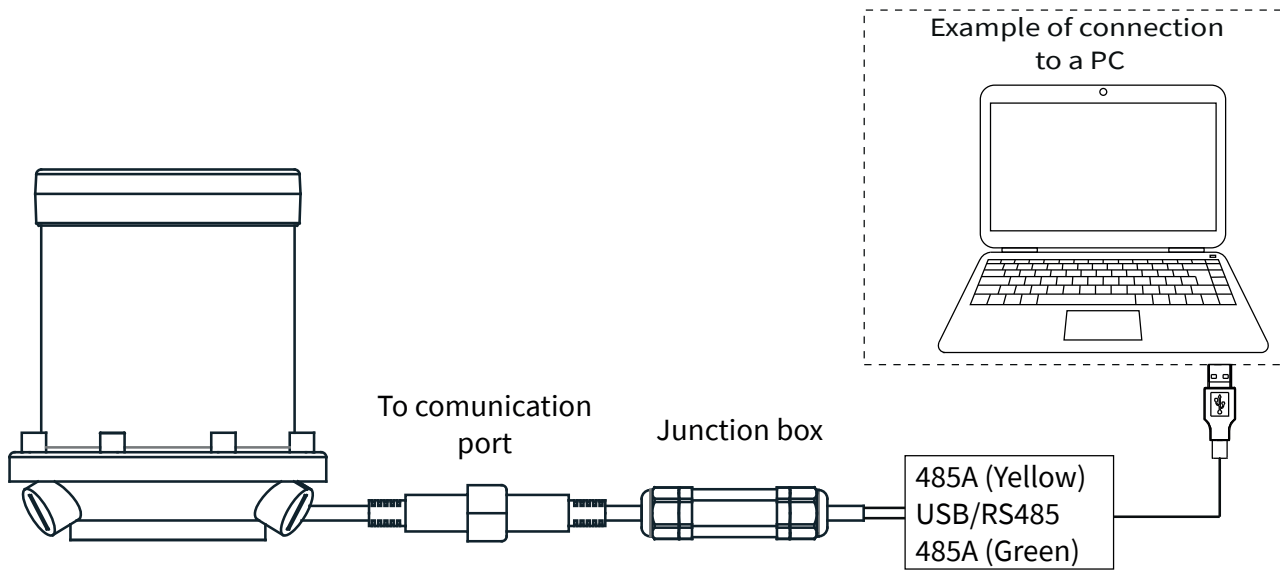

8.4 REMOTE VERSION

When installing the remote version, follow these guidelines to ensure correct measurements:

- 1) The cables must be laid out in an armoured conduit or fixed along their path to avoid errors in the measurements, especially for low conductivity fluids.
 - 2) Cables must be run away from electrical machinery and switching devices such as contactors or solenoid valves.
 - 3) Cable must not be run in conduits with power cables or switching devices
 - 4) When necessary, ensure equipotentiality between sensor and transmitter.
 - 5) The maximum length of the cables depends on the conductivity of the fluid. Refer to paragraph 8.5.2.
- Connect the sensor to the converter according to the diagram shown here below.

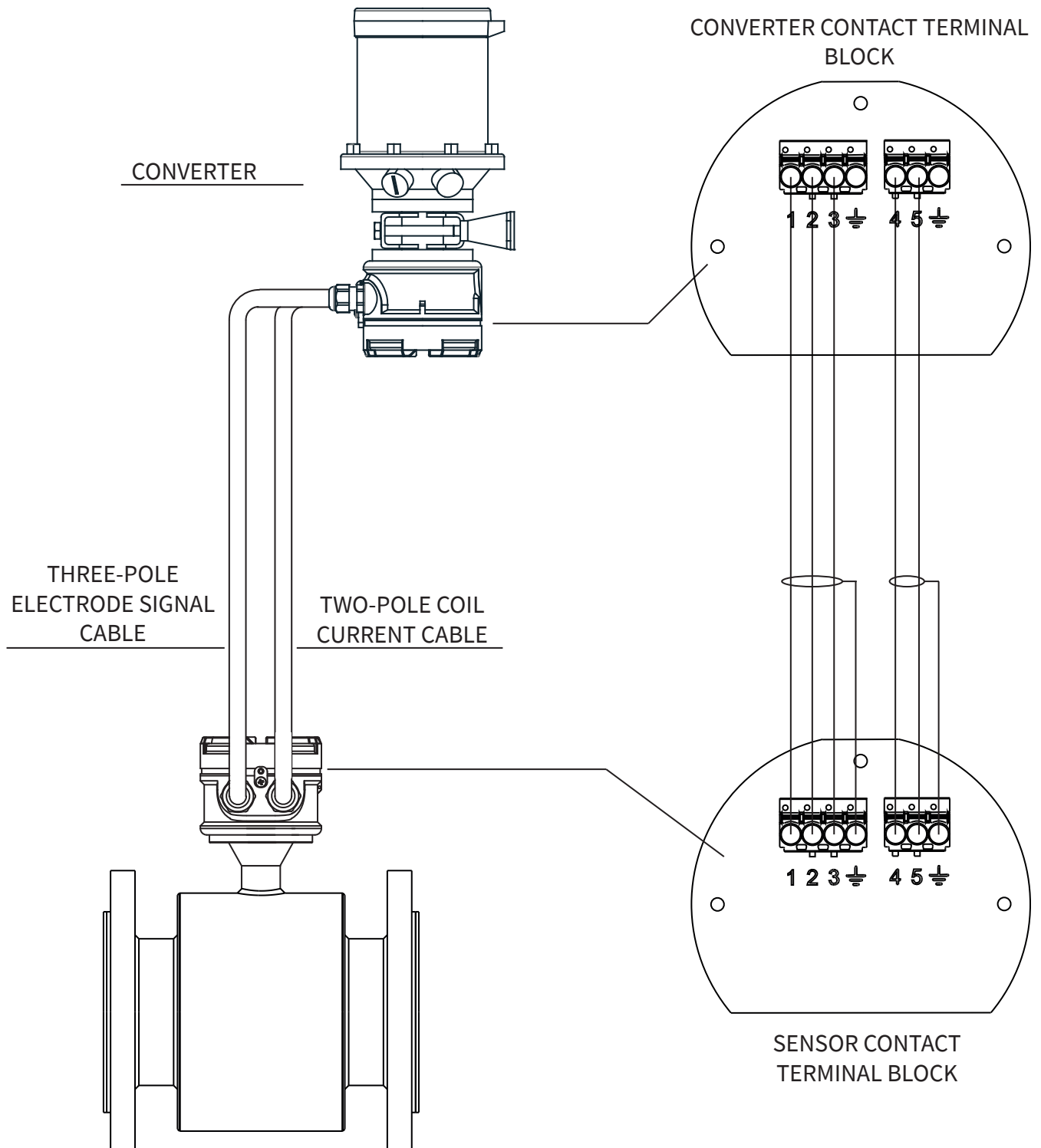

8.4.1 Wiring of remote version

Cable	Wire		Function	Terminal pos.
	Num.	Colour		
Two-pole	4	black	coil	4
	5	brown	coil	5
	braid		shielding	⏏
Three-pole	1	white	electrode 1	1
	2	yellow green	common GND	2
	3	brown	electrode 2	3
	braid		shielding	⏏

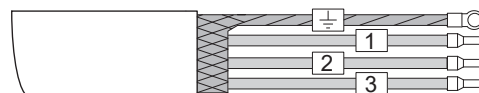

SHIELDED THREE-POLE CABLE

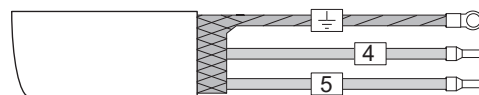

SHIELDED TWO-POLE CABLE

8.4.2 Length of connection cables

The fluid conductivity value determines the maximum length of the cables that connect the sensor to the converter. The grey area in the chart below indicates the permissible cable length in relation to the conductivity value of the fluid. With a fluid conductivity of 25 microS, for example, the maximum permissible length of the connection cables is 25 metres.

Cable length in metres

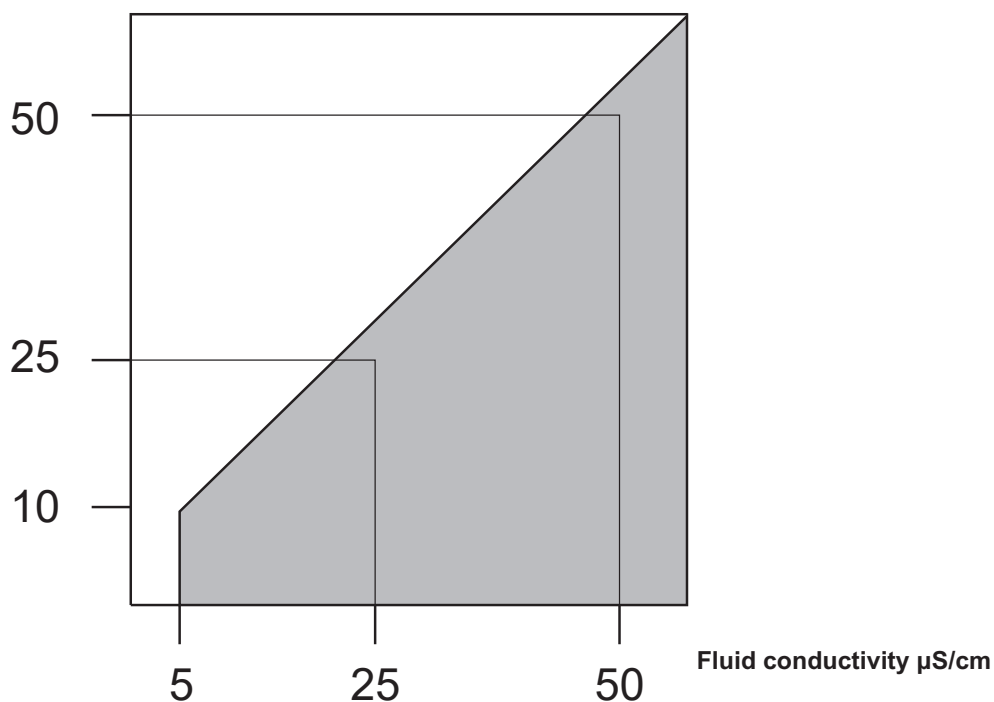

8.4.3 Connection cables

8.4.3.1 - Technical specification for the coil excitation cable

Shielded two-pole cable FR20H2R sec. 2x1.5	
Conductors	Class 5 tinned copper strands
Insulation	PVC R2 Ø 2.8mm ± 0,1
Colour of conductors	Black - Brown
Stranding	Concentric with polyester binding tape
Shielding	Tinned copper braid
Sheath	Hydrocarbon-resistant RZ PVC; Ø 8.2 mm ± 0.30; Black
Marking	525B005A
Operating temperature	-25 ÷ +70°C (fixed laying)
Test voltage	3KV VAC
Working voltage	450/750V
Electrical resistance of conductors	CEI 20-29
Reference standards	CEI 20-22 II-IEC 332.3A-ROHS 2011/65/UE(ROHS 2)

8.4.3.2 - Electrodes signal cable technical specification

Fr20H2R three-pole shielded cable sec. 3x1.5	
Conductors	Class 5 tinned copper strands
Insulation	PVC R2 Ø 2.8mm ± 0,1
Colour of conductors	White - Brown - Yellow/Green
Stranding	Concentric with polyester binding tape
Shielding	Tinned copper braid
Sheath	Hydrocarbon-resistant RZ PVC; Ø 8.4 mm ± 0.30; Black
Marking	525B004A
Operating temperature	-25 ÷ +70°C (fixed laying)
Test voltage	3KV VAC
Working voltage	450/750V
Electrical resistance of conductors	CEI 20-29
Reference standards	CEI 20-22 II-IEC 332.3A-ROHS 2011/65/UE(ROHS 2)

9-LOCAL OPERATOR INTERFACE (LOI)

The LOI is the user-machine interface. Through the LOI the operator can: access any function of the transmitter; change the settings of the configuration parameters; check the totalized value and other functions.

9.1 SAFETY MESSAGES

Instructions and procedures in this section may require special precautions to ensure the safety of the personnel carrying out the operations. Safety information will be highlighted by the warning symbol.

Refer to the following safety guidelines before performing an operation preceded by this symbol 

9.2 WARNINGS

Explosions may cause death or serious injury

- Check that the installation and operation area comply with the characteristics of the measuring tube and the transmitter.
- The installation must be carried out only and exclusively by skilled personnel.
- Do not perform any operations other than those described in this manual.

9.3 LOI FEATURES

The LOI features an alphanumeric liquid crystal display (LCD).

The supplied remote control is used to access and set the programming parameters; the magnetic key at the bottom of the remote control is used to select the display mode and to activate the procedure for accessing the system menu.

Approach the magnetic key to the "ACTIVE" button on the right to sequentially select the display of the instantaneous flow or the percentage (referring to the "maximum flow" value set).

Approach the magnetic key to the "ACTIVE" button on the left, to display sequentially the positive, negative or net totalizer.

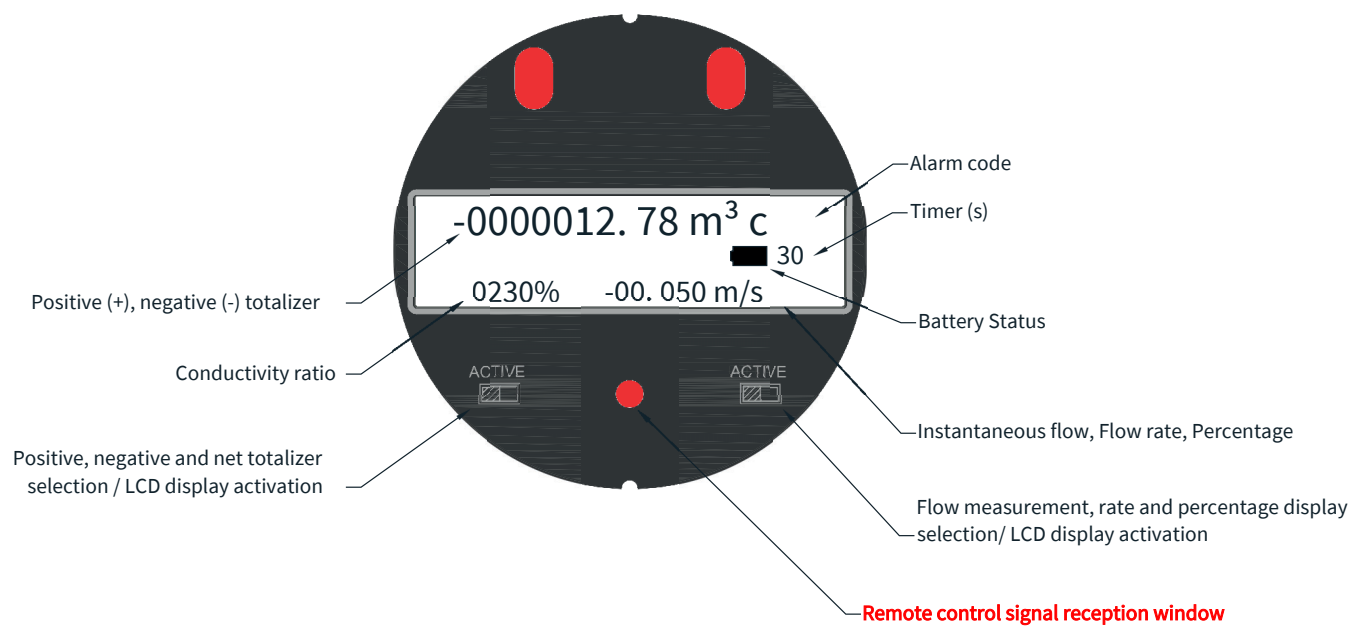

10-PROGRAMMING

10.1 RBMAG ACTIVATION

When RBmag is new, the converter is in sleep mode so as not to consume battery power; therefore the display and all functions are disabled.

To activate RBmag proceed as follows:

- 1) Approach the 2 magnetic keys to the 2 "ACTIVE" buttons
- 2) Enter the password 19818 and confirm with the ENTER button on the remote control
- 3) Press the BACK button on the remote control
- 4) Press the POWER button on the remote control to go into flow measurement mode (the battery symbol will be displayed on the right of the LCD display)

Note: The internal clock does not work when Rbmag is idle; after reactivating the instrument, check the date and time setting.

10.2 RBMAG SLEEP MODE

In order not to consume battery power, you can activate the sleep mode as follows:

- 1) Activate the display by approaching the supplied magnetic key to an "ACTIVE" button
- 2) Use the supplied magnetic key to select the display of the % by pushing the "ACTIVE" button on the right.
- 3) Press the left "ACTIVE" button until the display "flashes" and the wording "PUxx" appears (where xx are the seconds of the timer), instead of the "battery" symbol
- 4) Press the "M" (Menu) button on the remote control
- 5) Enter the password 19818 using the remote control
- 6) Access the menu PARAMETER SET > OPERATE MODE
- 7) Select the "Meter Dormancy" parameter and press ENTER on the remote control
- 8) Enter the password 23130 and press the BACK button on the remote control until you exit the programming menu.
- 9) Press the POWER button on the remote control

10.3 DATA INPUT

The remote control has numerical and control buttons to access the menu and configure RBmag; on the back, it is equipped with a magnet that act as a magnetic key.

To access the programming menu, proceed as follows:

- 1) Activate the display by approaching the supplied magnetic key to an "ACTIVE" button.
- 2) Use the supplied magnetic key to select the display of the % by pushing the "ACTIVE" button on the right.
- 3) Press the left "ACTIVE" button until the display "flashes" and the wording "PUxx" appears (where xx are the seconds of the timer), instead of the "battery" symbol.
- 4) Press the MENU button on the remote control.
- 5) Enter the password 19818 using the remote control.
- 6) Press the ENTER button on the remote control.

To resume measuring, exit the programming menu and press the POWER button on the remote control.

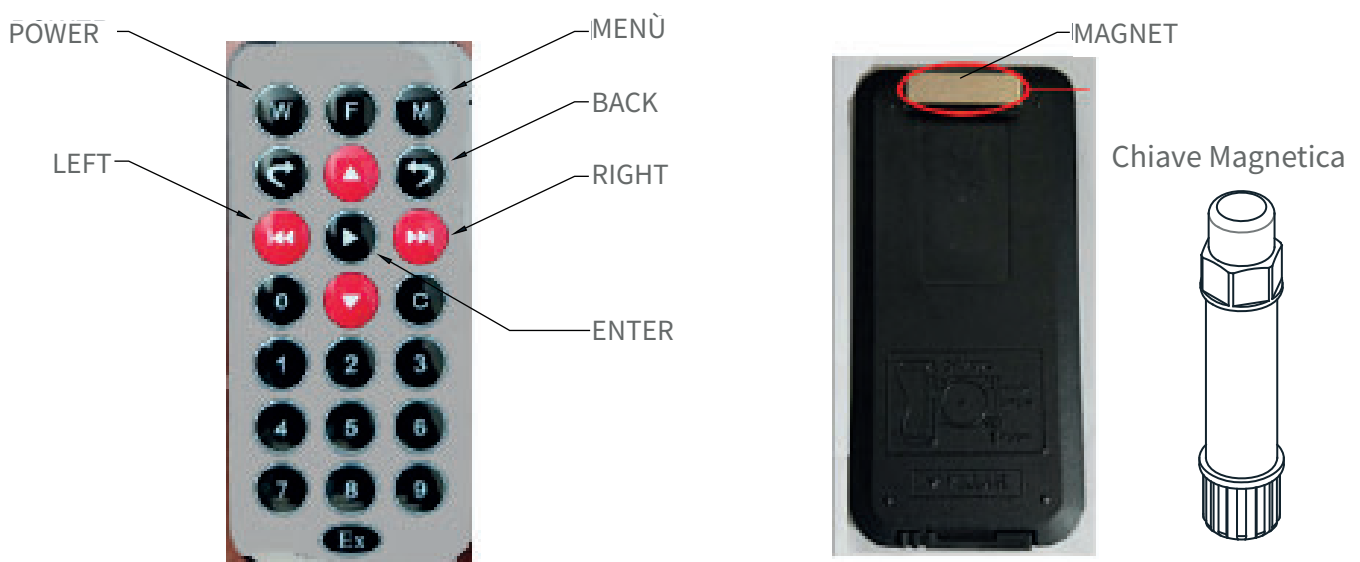

10.4 DISPLAY PAGES

In RUN mode, RBmag displays measurements and totalizers.
 Use the magnetic key on the "ACTIVE" button on the right to select the measurement to be displayed in the bottom right corner, with the sequence:

Instant flow

```
-0000012. 78 m3 c
      ■ 30
A 080. 0 -00. 050 m/s
```

Flow rate

```
-0000012. 78 m3 c
      ■ 30
A 080. 0 092.54 m3/h
```

Percentage of measurement

```
-0000012. 78 m3 c
      ■ 30
A 080. 0 03.274m/s
```

Use the magnetic key on the "ACTIVE" button on the left to select the measurement to be displayed in the top section, with the sequence:
 Positive totalizer

```
-0000012. 78 m3 c
      ■ 30
A 080. 0 032.72%
```

Negative Totalizer

```
+0001755826 m3 c
      ■ 30
A 080. 0 032.72%
```

Net totalizer

```
-0000012. 78 m3 c
      ■ 30
A 080. 0 -00. 050 m/s
```

```
D000163974 m3 c
      ■ 30
A 080. 0 -00. 050 m/s
```

10.5 PARAMETERS SET MENU

To access the PARAMETERS SET menu, follow the procedure described in the paragraph “DATA INPUT” by entering the 19818 password.

In the PARAMETERS SET menu, it is possible to make all the settings and calibrations for measuring the flow.

To access, press the ENTER button on the remote control

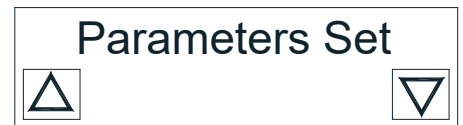
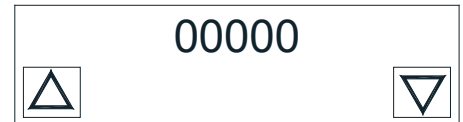

10.5.1 OPERATE MODE Menu

This menu contains the configuration parameters of the RBmag operating mode.

To access, press the ENTER button on the remote control.

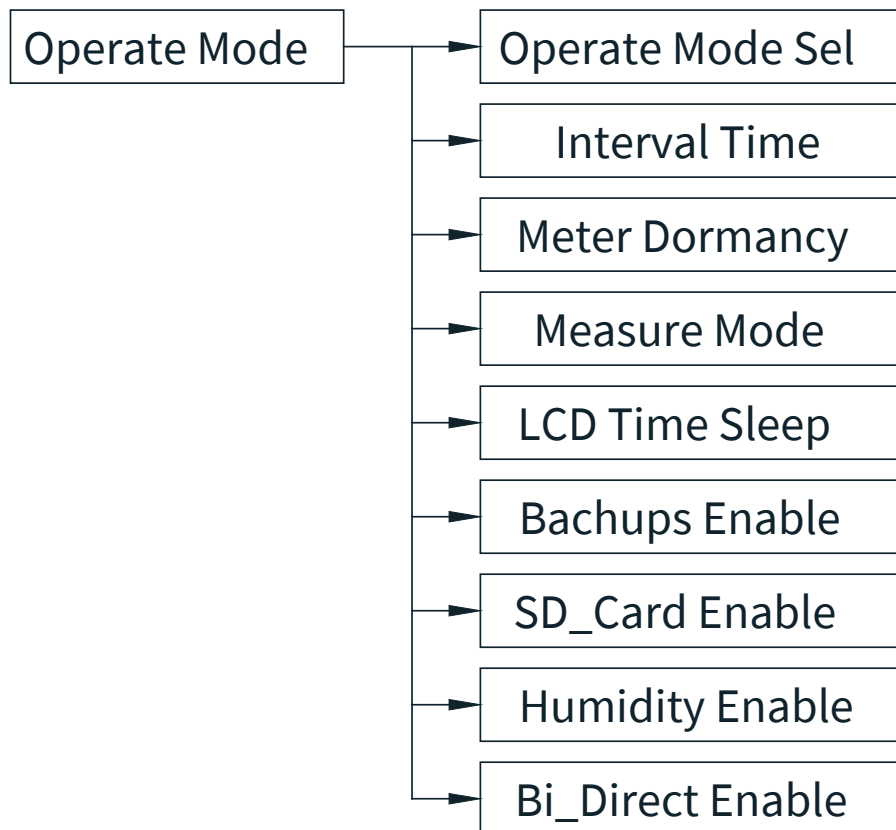
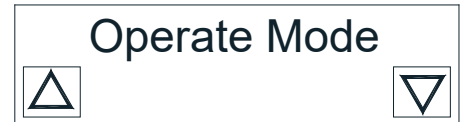

10.5.1.1 Operate Mode Sel

To select the converter operating mode.

The following options are available:

- “Flow only”; flow measurement only
- “Flow + Pressure” (not available)
- “Flow + Temperature”(Reserved) Press the BACK button to exit.

Default setting: “Flow only”.

Operate Mode Sel

▲
▼

Flow only

▲
▼

Interval Time

▲
▼

30 SEC

▲
▼

10.5.1.2 Interval Time

The RBmag measurement time interval can be set from 2 seconds to 30 seconds (if the setting is less than 15S, after 1h, the instrument setting will automatically switch to 15S).

Use the up or down arrow buttons to set the time interval.

Press the BACK button to exit.

Default setting: “30”.

10.5.1.3 Meter Dormancy

Activate the energy saving “sleep” mode by entering the password 23130 following the procedure described in paragraph “RBMAG SLEEP MODE”

When activated, RBmag stops all measurement and signal / data transmission functions.

To exit the energy saving mode, follow the procedure described in the paragraph “RBMAG ACTIVATION”.

Press the BACK button to exit. Default setting: “00000”.

Meter Dormancy

▲
▼

00000

▲
▼

10.5.1.4 Measure Mode

Reserved.

Meter Mode

▲
▼

10.5.1.5 LCD Time Sleep

In order to reduce the energy consumption of RBmag and therefore extend the life of the batteries, the converter automatically turns off the LCD at 00:00.

Turning off the LCD does not affect the normal measurement and communication function.

When “Enable” is set, the LCD shutdown function is active; when “DISABLE” is set, the LCD lock function is disabled.

Press the BACK button to exit. Default setting: “ENABLE”.

LCD Time Sleep

▲
▼

ENABLE

▲
▼

10.5.1.6 Backups Enable

Reserved.



10.5.1.7 SD_Card Enable

Reserved.

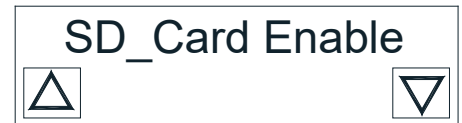

10.5.1.8 Humidity Enable

Reserved.



10.5.1.9 Bi_Direct Enable

Enables or disables the bidirectional flow measurement of the RBmag. The available settings are: “DISABLE”: bidirectional measurement disabled; “ENABLE”: bidirectional measurement enabled; Press the BACK key to exit. Default setting: “DISABLE”.



10.5.2 FLOW PARAMETER menu

This menu contains the configuration parameters of the RBmag flow measurement. To access, press the ENTER button on the remote control

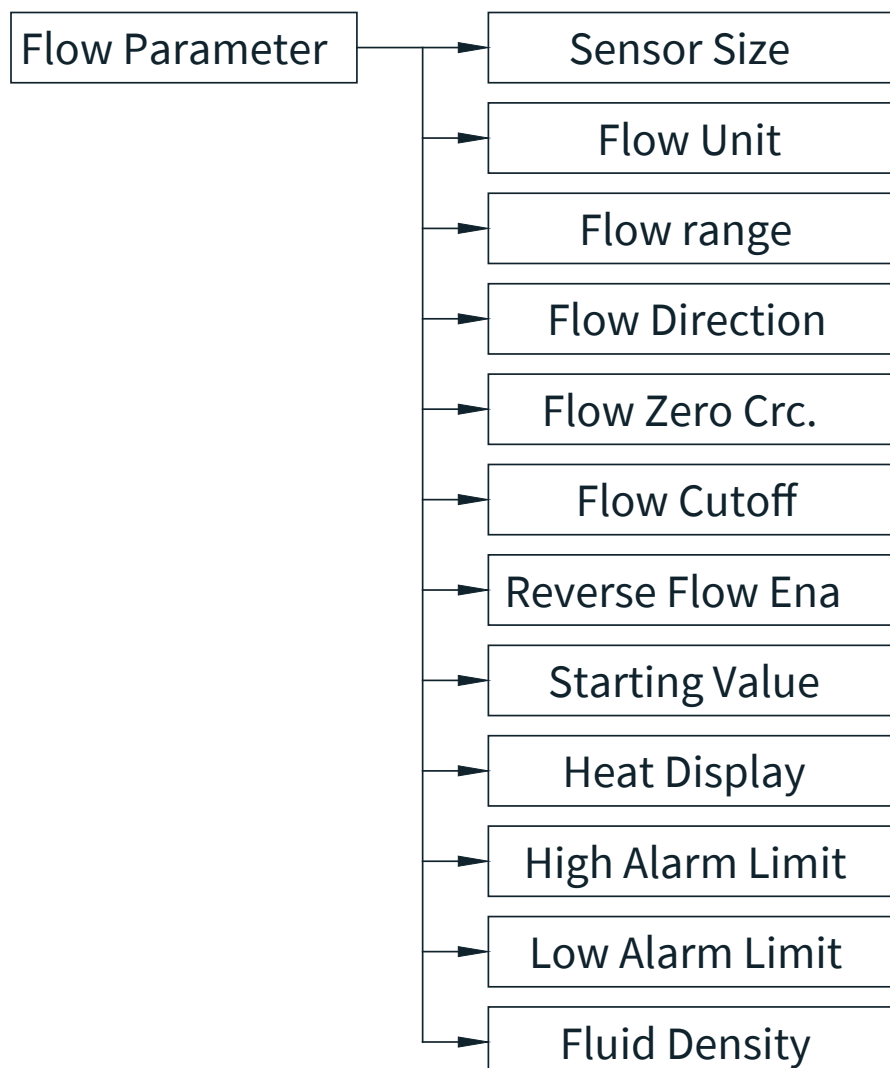

10.5.2.1 Sensor Size

Selectable sensor tube sizes are 10 to 2000 mm.
 Press the up or down arrow to change the diameter DN of the tube.
 Press the BACK button to exit.
 Default setting: Standard diameter of the sensor tube

▲	Sensor Size	▼
---	--------------------	---

▲	100mm	▼
---	-------	---

10.5.2.2 Flow Unit

The selectable instantaneous flow rate units are:
 L/s; L/m; L/h; m3/s; m3/m; m3/h; uk/s; uk/m; uk/h; us/s; us/m; us/h; kg/s;
 kg/m; kg/h; t/s; t/m; t/h.
 Press the up or down arrow to select the unit of measurement.
 Press the BACK button to exit.
 Default setting: "m3/h"

▲	Flow Unit	▼
---	------------------	---

▲	100mm	▼
---	-------	---

10.5.2.3 Flow Range

To set the "Flow Range" value (max flow), use the digit buttons on the remote control.
 Press the BACK button to exit.
 Default setting: maximum flow value of the sensor tube

▲	Flow Range	▼
---	-------------------	---

▲	282.75 m3/h	▼
---	----------------	---

10.5.2.4 Flow Direction

If the direction of the flow is not correct, just operate on the parameter to reverse the positive direction of the flow by selecting "REVERSE"
 Press the BACK button to exit.
 Default setting: "FORWARD"

▲	FORWARD	▼
---	----------------	---

▲	LCD Time Sleep	▼
---	-----------------------	---

10.5.2.5 Flow Zero Crc.

When performing zero correction, make sure the sensor tube is full, and the fluid is still. The zero point of the flow is shown as flow rate, mm / s. indicates the zero

The upper line indicates the zero of the correct flow, and the lower line ZR
 When the FZ display is not "0", perform the correction to set FZ to "0".
 Note: if the value of the FZ line increases, you need to change the "+, -" in the top line to make sure that the FZ display is zero.
 Press the BACK button to exit. Default setting: "+000.0"

▲	Flow Zero Crc.	▼
---	-----------------------	---

32	000.0	E1
▲	FZ=+00001.1	▼

10.5.2.6 Flow Cutoff

Specifies the instantaneous flow value below which the instantaneous flow reading (direct or reverse) and the outputs are forced to zero.
Press the BACK button to exit. Default setting: "001.00"

△	Flow Cutoff	▽
---	--------------------	---

△	001.00 m3/h	▽
---	----------------	---

10.5.2.7 Flow Filter Time

Allows setting a time delay, in seconds, for reading variations.
It is used to lessen the flow measurement fluctuations. Press the BACK button to exit.
Default setting: "20 Sec"

△	Flow Filter Time	▽
---	-------------------------	---

△	20 Sec	▽
---	--------	---

10.5.2.8 Reverse Flow Ena

When it is disabled ("DISABLE"), the function of the RBmag converter is to disable the reverse flow: the negative flow is not displayed or counted; When it is enabled ("ENABLE"), RBmag also shows and counts the negative flow.
Press the BACK button to exit. Default setting: "ENABLE"

△	Reverse Flow Ena	▽
---	-------------------------	---

△	ENABLE	▽
---	--------	---

10.5.2.9 Starting Value

RBmag analyzes the variation of the flow speed between 2 samplings and, when the variation is greater than the threshold set in "Starting Value", RBmag automatically starts the fast frequency measurement to ensure the accuracy of the measurement.
When the flow variation goes back to being lower than the set threshold, RBmag resumes measuring according to the programmed time interval.
Press the BACK button to exit. Default setting: "01.000m/s"

△	Starting Value	▽
---	-----------------------	---

△	01.000m/s	▽
---	-----------	---

10.5.2.10 Heat Display

Reserved.

△	Heat Display	▽
---	---------------------	---

10.5.2.11 High Alarm Limit

When the flow value is higher than the set threshold, the alarm is transmitted only via digital communication.

This alarm is not shown on the display and does not generate output signals. Press the BACK button to exit

10.5.2.12 Low Alarm Limit

When the flow value is less than the set threshold, the alarm is transmitted only via digital communication.

This alarm is not shown on the display and does not generate output signals. Press the BACK button to exit

10.5.2.13 Fluid density

When the flow unit is set to kg / h, kg / m, kg / s, t / h, t / met / s, this parameter is active.

The maximum setting can be 5.9999.

RBmag does not show the unit of kg and kg / L, or T and t / measurement on the display when it is set in Press the BACK key to exit.

Default setting: "1.0000"

High Alarm Limit	
△	▽
282.74 m3/h	
△	▽
Low Alarm Limit	
△	▽
028.27 m3/h	
△	▽
Fluid density	
△	▽
1.0000	
△	▽

10.5.3 OUTPUT PARAMETER menu

This menu contains the configuration parameters of the output signals.
To access, press the ENTER button on the remote control.

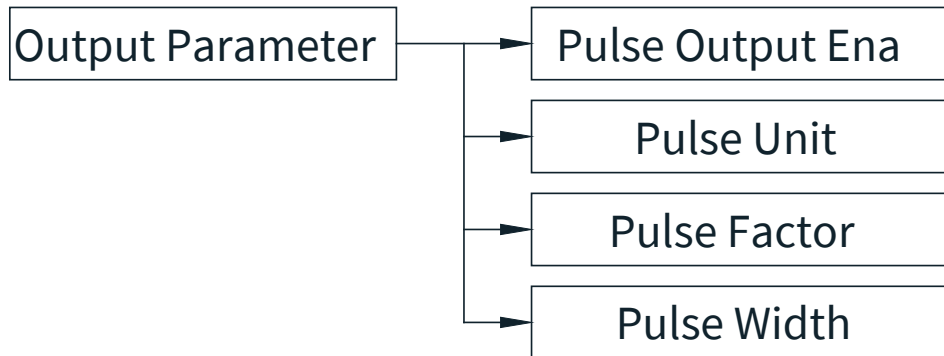

10.5.3.1 Pulse Output Ena

To enable or disable the pulse output.
When ENABLE is set, the function is enabled; when DISABLE is set, the function is disabled.
Press the BACK button to exit. Default setting: "ENABLE"

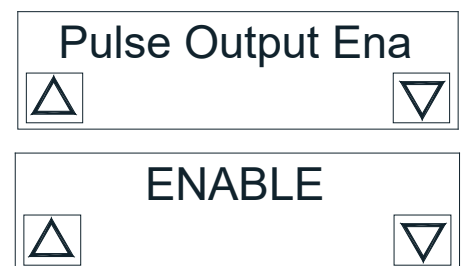

10.5.3.2 Pulse Unit

The units of measurement of the pulse output that can be selected are:
L, m3, ukg, usg, kg, t.
Press the up or down arrow to select the unit of measurement.
Press the BACK button to exit.
Default setting: "m3"

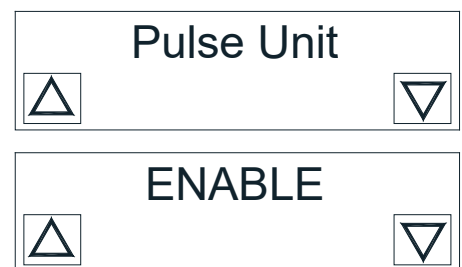

10.5.3.3 Pulse Factor

It is the weight of the pulse; the interval is between 0.0001 ÷ 5.9999.
The unit of measurement depends on the setting in the "Pulse Unit" parameter.
Press the BACK button to exit. Default setting: "1.0000"

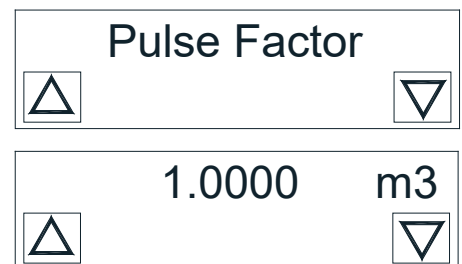

10.5.3.4 Pulse Width

It is the width of the pulse; the interval is between 00.05 ÷ 12.50 ms.
Press the BACK button to exit.
Default setting: "12.50"

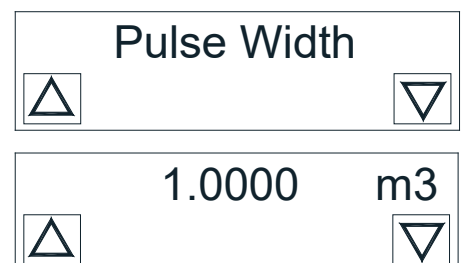

10.5.4 SENSOR PARAMETER menu

This menu contains the configuration and calibration parameters of the sensor tube.

To access, press the ENTER button on the remote control.

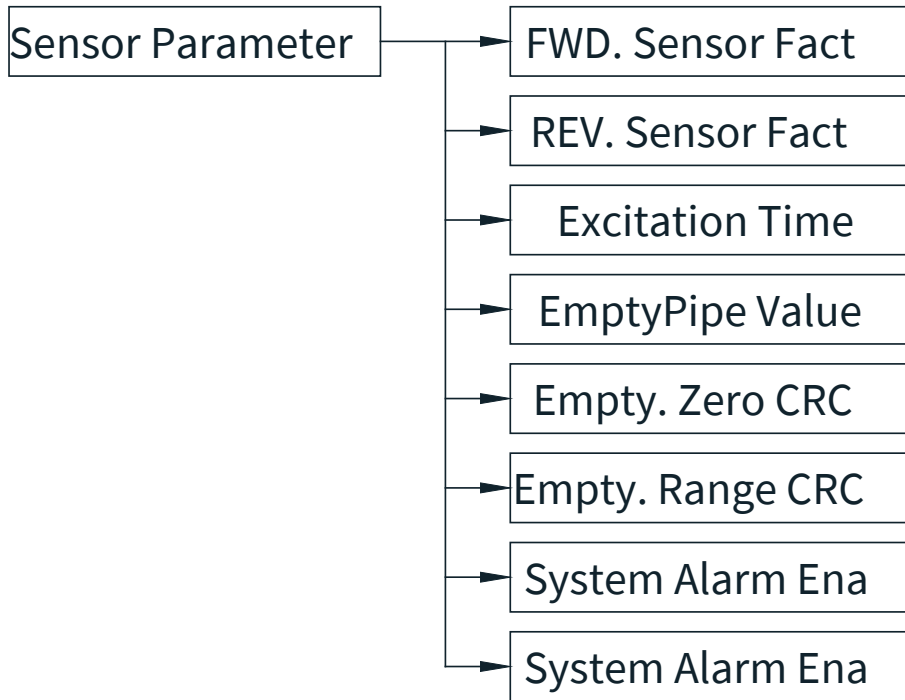
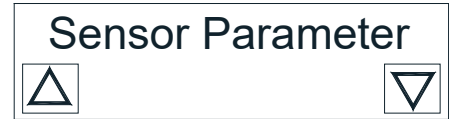

10.5.4.1 FWD. Sensor Fact

It is the calibration factor of the sensor tube.
 Its value is shown on the data plate and on the calibration certificate.
 By default, it is the same value set for the "REV. Sensor Fact".
 Press the BACK button to exit.

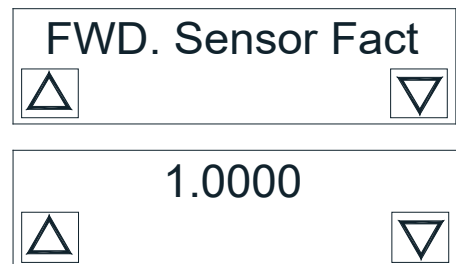

10.5.4.2 REV. Sensor Fact

It is the calibration factor of the sensor tube.
 Its value is shown on the data plate and on the calibration certificate.
 By default, it is the same value set for the "FWD. Sensor Fact".
 Press the BACK button to exit.

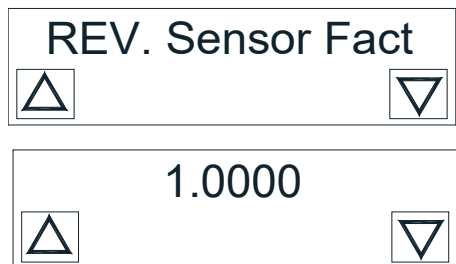

10.5.4.3 Excitation Time

There are two possible excitation modes: TYPE1 and TYPE2.
 For small diameter pipes, select TYPE1.
 For large diameter pipes, select TYPE1.
 During use, first select TYPE1 excitation; if the meter displays
 "flow too high" or SYS, select TYPE2.
 Press the BACK button to exit

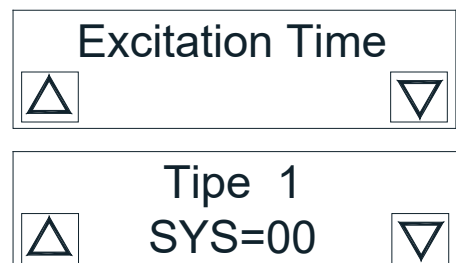

10.5.4.4 Sensor Coding

Reserved.



10.5.5.5 Empty Pipe Value

This is the empty pipe recognition threshold.
Set the empty pipe recognition threshold (upper line) to a value equal to $1.5 \div 2$ times the value of MZ (R%) during the full pipe condition.
When the pipe is empty, the MZ value increases and when the threshold is exceeded, the pipe empty signal is triggered.
Press the BACK button to exit. Default setting: "00100"

Empty Pipe Value		
△		▽

00100		
△	MZ= 00001	▽

10.5.5.6 Empty Zero CRC

It is the correction of the "Empty Pipe zero-point".
When performing calibration, make sure the sensor tube is full.
The "empty pipe zero-point" correction is displayed as follows:
Top line: calibrated empty pipe zero-point.
Bottom line: MZ indicates the measured zero-point;
Based on the actual measured conductivity R%, carry out the correction to obtain MZ = 5-10.
Note: by increasing the value of the upper line, the lower MZ row decreases.
Press the BACK button to exit. Default setting: "00000"

Empty Zero CRC		
△		▽

00000		
△	MZ= 00002	▽

10.5.5.7 Empty Range CRC

It is the correction of the "full pipe zero-point" when the conductivity R% is small. When performing calibration, make sure the sensor tube is empty.
The "full pipe zero-point" correction is displayed as follows:
Top line: "Full pipe zero-point" calibrated.
Bottom line: MR indicates the measured zero-point;
When the value of the upper line increases, the MR decreases;
vice versa, when the value of the upper line decreases, the MR increases.
The MR can be adjusted to the correct value based on the actual empty pipe condition with the actual MR value.
Press the BACK button to exit. Default setting: "10000"

Empty Range CRC		
△		▽

10000		
△	MR= 00002	▽

10.5.5.8 System Alarm Ena

Enables (ENABLE) or disables (DISABLE) the system alarm.
Press the up or down arrow to select the unit of measurement.
Press the BACK button to exit. Default setting: "ENABLE"

System Alarm Ena		
△		▽

ENABLE		
△		▽

10.5.5.9 Excit. Value Set

Reserved.

Excit. Value Set		
△		▽

10.5.6 FWD menu. LINEARIZED.

Reserved.

FWD. Linearizati.		
△		▽

10.5.7 REV. menu LINEARIZED.

Reserved.

REV. Linearizati.		
△		▽

10.5.8 Menu TEMP. PARAM

Reserved.

Temperat Parame.		
△		▽

10.5.9 Menu . COMMUNICATION.

This menu contains the configuration parameters of the MODBUS RTU communication port.

To access, press the ENTER button on the remote control.

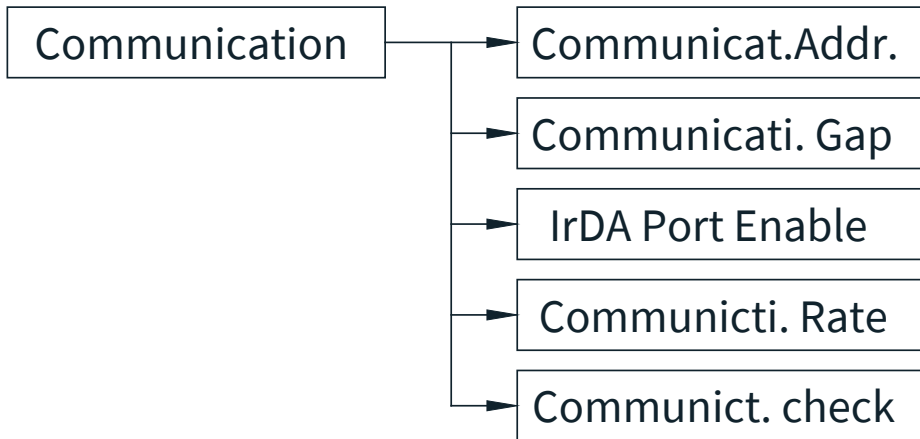

10.5.9.1 Communicat.Addr.

It is the UID address of RBmag.

Range from 1 to 199

Press the BACK button to exit. Default setting: "001".

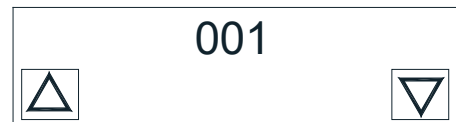

10.5.9.2 Communicat.Gap.

The communication gap is used to send data to the communication terminal, set the range: 01 ÷ 199s. If the time interval is short, the power consumption of the meter communication modules will be higher.

Press the BACK button to exit.

Default setting: "00014S".

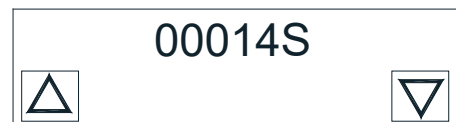

10.5.9.3 IrDA Port Enable

Reserved.



10.5.9.4 Communicat. Rate

This is the transmission BAUD RATE.

The selectable values are: 1200, 2400, 4800, 9600, 14400

Press the BACK button to exit

Default setting: "9600".

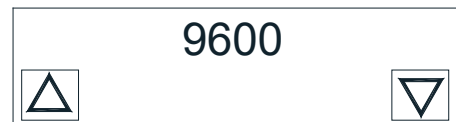

10.5.9.5 Communic. check

This is the transmission parity.
 The selectable settings are: No Parity, Odd Parity, Even Parity.
 Press the BACK button to exit.
 Default setting: "No Parity".

Empty Pipe Value

00100
 MZ= 00001

10.5.10 Menù FACTORY ADJUST

Reserved.

Empty Zero CRC

10.5.11 Menù TOTAL PARAMETER

This menu contains the configuration parameters of the RBmag totalizers.
 To access, press the ENTER button on the remote control.

00000
 MZ= 00002

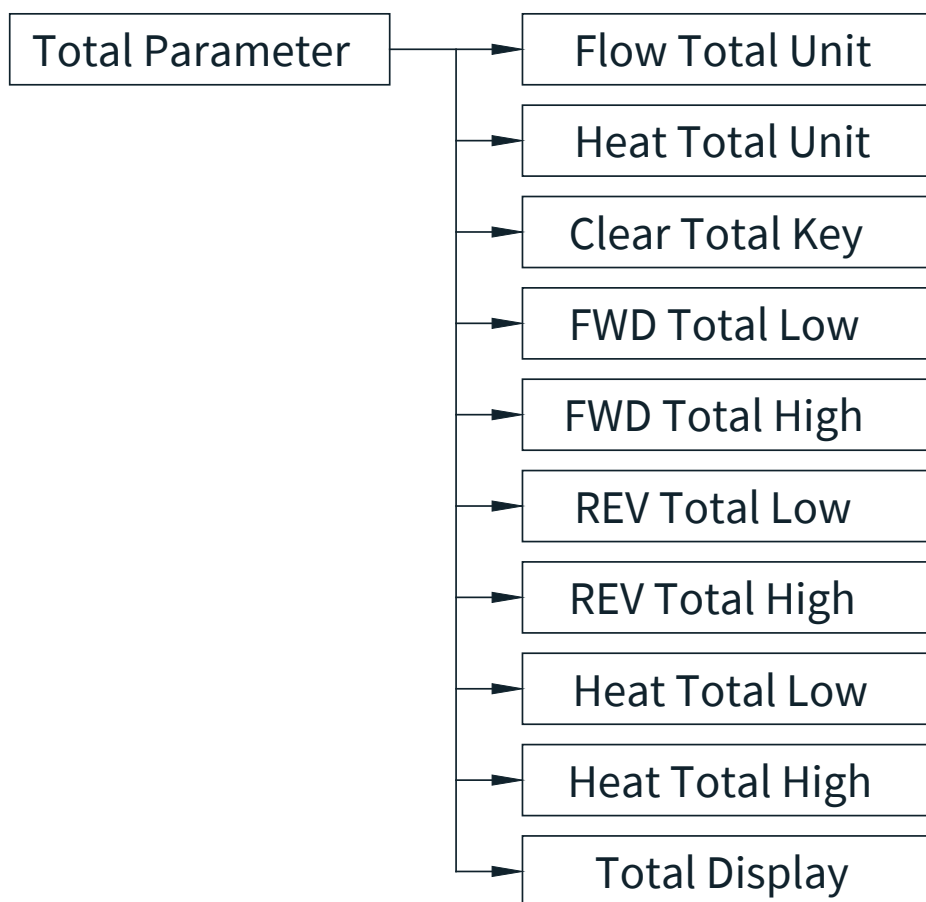

10.5.11.1 Flow Total Unit

The units of measurement of the instantaneous flow and the number of decimals to be displayed. The selectable settings are: 0.001 Ltr, 0.01 Ltr, 0.1 Ltr, 1 Ltr, 0.001 m3, 0.01 m3, 0.1 m3, 1 m3, 0.001 ukg, 0.01 ukg, 0.1 ukg, 1 ukg, 0.001 usg, 0.01 usg, 0.1 usg, 1 usg, 0.001 kg, 0.01 kg, 0.1 kg, 1 kg, 0.001 t, 0.01 t, 0.1 t, 1 t.

Press the up or down arrow to select the unit of measurement.

Press the BACK button to exit.

Default setting: "1. m3"

Flow Total Unit

▲ ▼

1. m3

▲ ▼

10.5.11.2 Heat Total Unit

Reserved.

Heat Total Unit

▲ ▼

10.5.11.3 Clear Total Key

Reserved

Clear Total Key

▲ ▼

00000

▲ ▼

10.5.11.4 FWD Total Low

Presets the 5 low digits of the positive totalizer.

Enter a number from 00001 to 99999.

Press the up or down arrow to select the unit of measurement.

Press the BACK button to exit

FWD Total Low

▲ ▼

00000

▲ ▼

10.5.11.5 FWD Total High

Presets the 5 high digits of the positive totalizer.

Enter a number from 00001 to 99999.

Press the up or down arrow to select the unit of measurement.

Press the BACK button to exit.

FWD Total High

▲ ▼

00000

▲ ▼

10.5.11.6 REV Total Low

Presets the 5 low digits of the positive totalizer.
 Enter a number from 00001 to 99999.
 Press the up or down arrow to select the unit of measurement.
 Press the BACK button to exit.

REV Total Low	
▲	▼

00000	
▲	▼

10.5.11.7 REV Total High

Presets the 5 high digits of the negative totalizer.
 Enter a number from 00001 to 99999.
 Press the up or down arrow to select the unit of measurement.
 Press the BACK button to exit.

REV Total High	
▲	▼

00000	
▲	▼

10.5.11.8 Heat Total Low

Reserved.

Heat Total Low	
▲	▼

10.5.11.9 Heat Total High

Reserved.

Heat Total High	
▲	▼

10.5.11.10 Total Display

To select which totalizers are visible on the display.
 The selectable settings are: Flow +, Flow-, FD; Heat Quantity (inactive);
 Flow +, Heat (inactive); Flow +, Flow-, LM (LM = automatic scroll of the
 totalizers); F +, F-, FD, LM (LM = automatic scroll of the totalizers);
 Flow +, Heat, LM (inactive); Flow +; Flow +, Flow-.
 Press the BACK button to exit. Default setting: "Flow+,Flow-,FD".

Total Display	
▲	▼

Flow+,Flow-,FD	
▲	▼

10.5.12 PRESSURE PARAM. menu.

Reserved.

Pressure Parame.	
▲	▼

10.5.13 TEST PARAMETER menu

Reserved.

Test Parameter		
△		▽

10.6 RESET TOTAL REC. MENU

Reserver

Reset Total Rec.		
△		▽

10.7 FWD FLOW TOTAL MENU

Reserved.

FWD Flow Total		
△		▽

10.8 REV FLOW TOTAL MENU

Reserved.

REV Flow Total		
△		▽

10.9 DATE TIME SET MENU.

To access the DATE TIME SET menu, follow the procedure described in the paragraph "DATA INPUT" by entering the 19818 password.

From the DATE TIME SET menu it is possible to set the correct date and time. Press the RIGHT button to move the cursor and go to the time setting. Press the BACK button to exit.

Data Time Set		
△		▽

YEAR	MON	DAY
21	02	23

HOUR	MIN	SEC
12	15	07

10.10 HEAT TOTAL RECO MENU.

Reserved.

Heat Total Reco.		
△		▽

10.11 ERROR RECORD MENU

Reserved.

Error Record		
△		▽

10.12 MODIFICAT RECORD MENU

Reserved.

Modificat Record		
△		▽

10.13 BACKUP PARAMETS MENU

Reserved.

Backup Paramets		
△		▽

10.14 RECOVERY PARAMETS MENU

Reserved.

Recovery Paramets		
△		▽

11-TROUBLESHOOTING

Problems in the electromagnetic measuring system usually result in incorrect system readings and outputs, error messages, or failed tests. All sources must be considered in order to identify a problem in the system.

Anomaly	Probable cause	Correttive action
Pulse output at zero, regardless of the flow	No power supply voltage	Check battery and converter connections
	Wiring error	Check the connections to the terminals. Refer to the wiring diagrams
	Flow in reverse direction	Activate the Reverse Flow function
	Faulty electronics	Replace the circuit board
Flow measurement apparently incorrect	Incorrect configuration of the control system, transmitter or other receiving device	Check all configuration variables for the transmitter, measuring tube, communicator and / or control system. Perform a test cycle to check the integrity of the circuit
	Electrode covered by residual deposits	Reduce the section of the measuring tube to reach an average flow velocity higher than 3m / s. Periodically clean the measuring tube
	Air in the pipe	Move the measuring tube to a position that ensures it remains full in all conditions
	Flow speed less than 0.3 m / s (see specification)	See the accuracy specifications for the transmitter and measuring tube
	Auto-zero was not performed when the measuring tube was full or with zero flow	Run the auto-zero function
	Measuring tube error - shorted electrode	Test the measuring tube electrode
	Measuring tube error - shorted or open coil	Test the coil
	Faulty transmitter	Replace the circuit boards

Process disturbances:

In some circumstances, process conditions can cause measurement instability.

The procedure for resolving a measurement instability situation is described here below.

Perform it as described in sequence.

When the measurement stabilizes, no further steps are required:

1. Increase damping.
2. Activate signal processing.

If the basic troubleshooting procedures are not sufficient, contact our headquarters.

Anomaly	Probable cause	Correttive action
Process disturbances	Chemical additives upstream of the magnetic flow meter	Move the injection point downstream of the magnetic flow meter.
	Mine sludge / Coal / sand (other fluids with hard particles in suspension)	Decrease the flow rate
	Styrofoam or other insulating particles in the process	Contact our headquarters
	Dirty electrode	Reduce the pipe section to increase the flow rate. Periodically clean the electrodes
	Air in the pipe	Move the sensor to a position that ensures there is no air inside the tube
Unstable outputs	Electrode incompatibility	Check the chemical compatibility of the electrode material
	Incorrect grounding	Check the ground wiring
	High electromagnetic fields nearby	Move the sensor away from sources of electromagnetic disturbance
	Flow regulators	Adjust the flow
	Sensor anomaly	Perform sensor test

12-FACTORY TEST AND QUALITY CERTIFICATE



In conformity to the company and check procedures I certify that the equipment:

(Electromagnetic induction flow measurement)

is conform to the technical requirements on Technical Data and it is made in conformity to the procedure

Quality Control Manager: Production and check date:

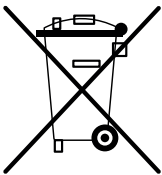

This mark on the instrument indicates that the product and its electronic accessories must not be disposed of with other household waste at the end of their useful life.

To avoid possible damage to the environment or human health resulting from uncontrolled waste disposal, please return the equipment directly to a specialized recycling company, in compliance with local regulations.

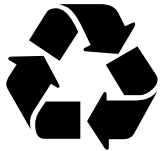

NI - MH

This instrument is powered by a battery type Li/SOCI2 / 3.6V 16000mA/h; at the end of the life of the battery or the instrument, do not disperse it in the environment. The battery must be disposed of in the appropriate collection centers.