

MCA800 Chemical analysis

Measurement of pH, Redox, Infrared Turbidity, Suspended Solids, Conductivity and Dissolved Oxygen.

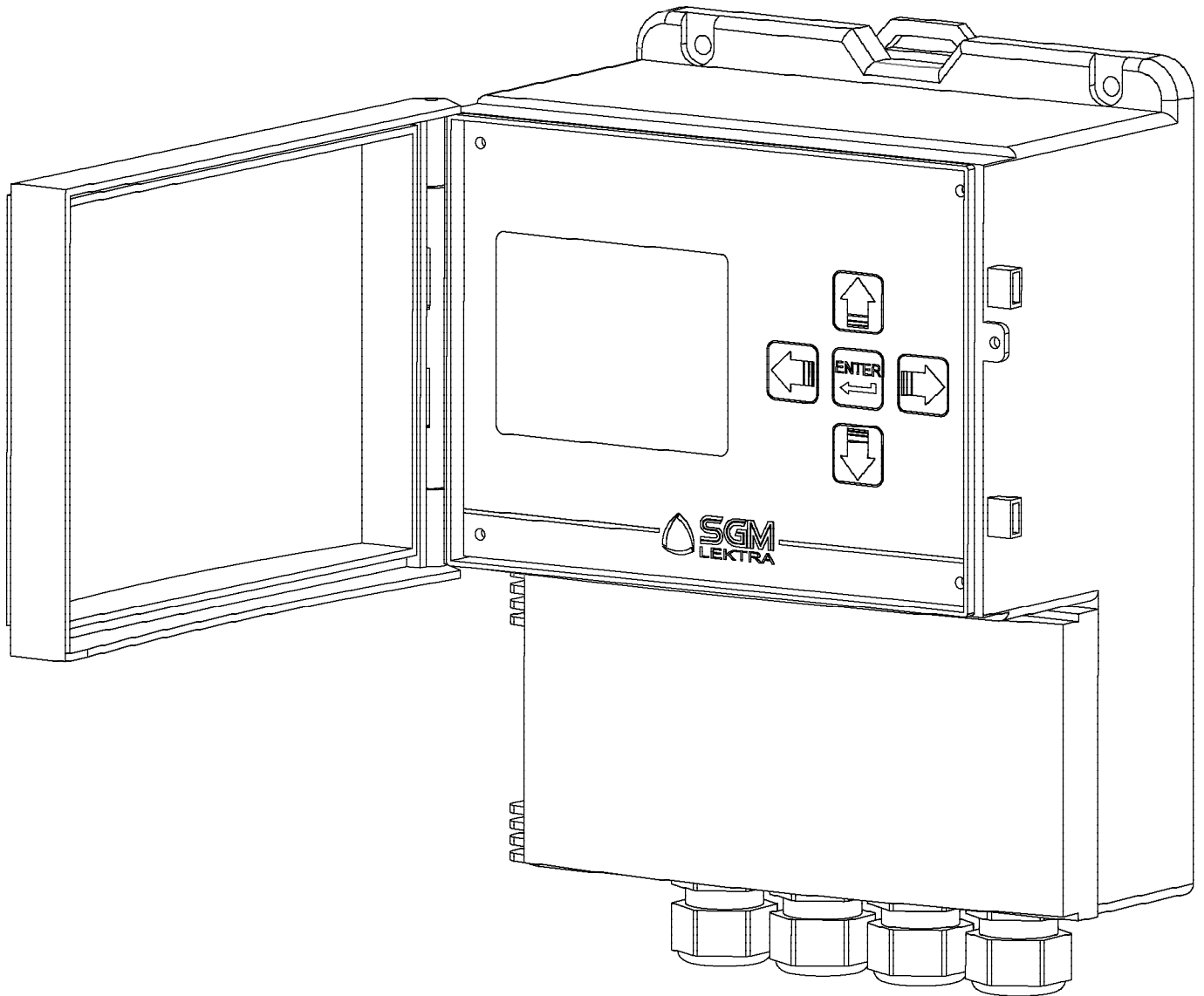

technical documentation ENG Revision of 21/03/2023

TABLE OF CONTENTS

1-WARRANTY	page 3
2-PRODUCT	page 4
3-TECHNICAL SPECIFICATIONS	page 5
4-DIMENSIONS	page 6
5-INSTALLATION	page 7
6-ELECTRICAL CONNECTIONS	page 9
7-PROGRAMMING	page 11
8-PH DIGITAL MEASUREMENT	page 14
9-CONDUCTIVITY DIGITAL MEASUREMENT	page 19
10-DISSOLVED OXYGEN OPTICAL MEASUREMENT	page 25
11-INFRARED TURBIDITY MEASUREMENT	page 32
12-INFRARED HIGH TURBIDITY MEASUREMENT	page 39
13-INFRARED SUSPENDED SOLIDS MEASUREMENT	page 49
14-REDOX MEASUREMENT (ORP)	page 52
15-MCA800 CONFIGURATION	page 55
16-TESTING / QUALITY CERTIFICATE	page 68

1-WARRANTY

SGM-LEKTRA SRL undertakes to remedy any fault, defect or absence, occurring within 12 months from the delivery date, provided that it is attributable to it and has been communicated within the prescribed time limit.

SGM LEKTRA SRL may choose whether to repair or replace the faulty Products.

The Products replaced under warranty will have an additional 12 months warranty.

The Products repaired under warranty will have a warranty until the original time limit.

The parts of the Products repaired out of warranty will have a 3 months warranty.

The Products are only guaranteed to meet particular specifications, technical characteristics or conditions of use if this is expressly agreed in the Purchase Agreement or in the documents referred to therein.

The warranty of SGM-LEKTRA SRL absorbs and replaces the warranties and responsibilities, both contractual and non-contractual, originating from the supply such as, for example, compensation for damages, reimbursement of expenses, etc., both towards the Customer and towards third parties.

The warranty is void in the event of tampering with or improper use of the Products.

2-PRODOTTO

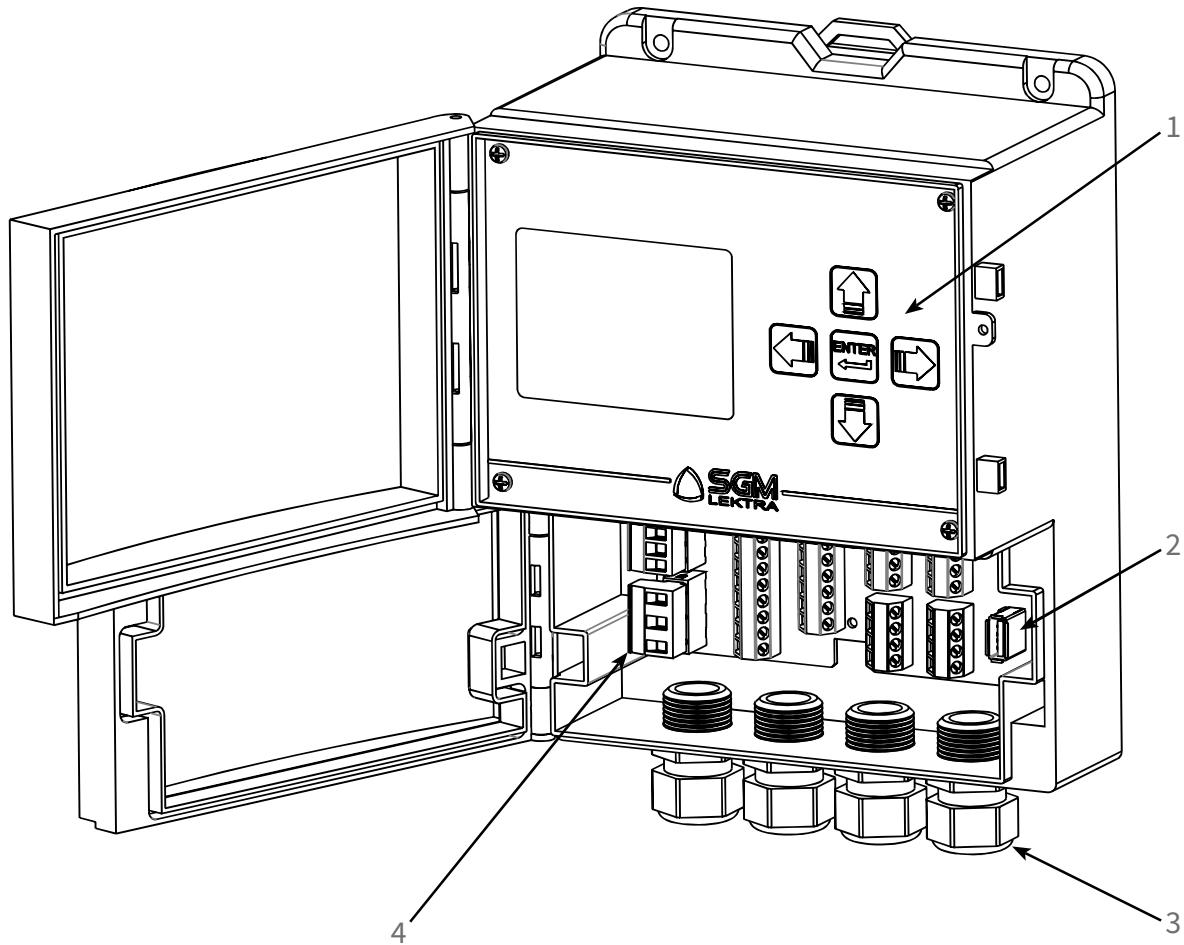

1. Keyboard
2. USB Pen Drive for DATALOGGER
3. N°4 Skintop M20x1.5
4. Terminal blocks

2.1 IDENTIFICATION

Each instrument has an adhesive identification plate on which the main instrument data are reported. The following image describes the information and data on the plate.

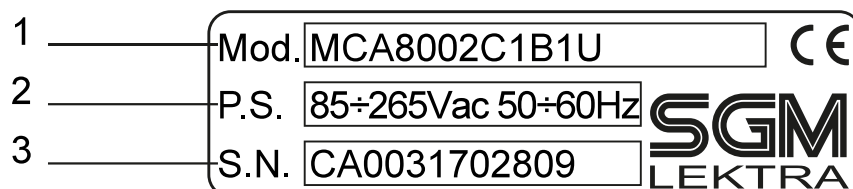

1. Product code

2. Supply voltage

3. Serial number

3-TECHNICAL SPECIFICATIONS

Housing material

ABS

Mechanical installation

assembly on wall, on a pole or on DIN bar

Protection rating

IP66

Keyboard

5 keys

Display

Backlit 320x240 matrix colour LCD

Electrical connection

Terminal blocks

Operating temperature

-20 ÷ +60°C

Power supply

85÷265Vac; 20÷30Vdc/Vac

Power absorbed

Max. 10W

Analogical output

n.2 4 ÷ 20mA configurable; isolated

Relay output

n.5 configurable relays (5A 250Vac)

Digital outputs

n.2 open collector (max. 24Vdc 50mA)

Analog inputs

n.2 4÷20mA

Digital inputs

n.2 (max. 24Vdc 10mA)

Digital communication

MODBUS RTU

Datalogger

on USB Pen Drive; max.32GB (FAT32)

Power supply for analogical transmitters

24Vdc; 200mA max

4-DIMENSIONS

4.1 - MECHANICAL DIMENSIONS

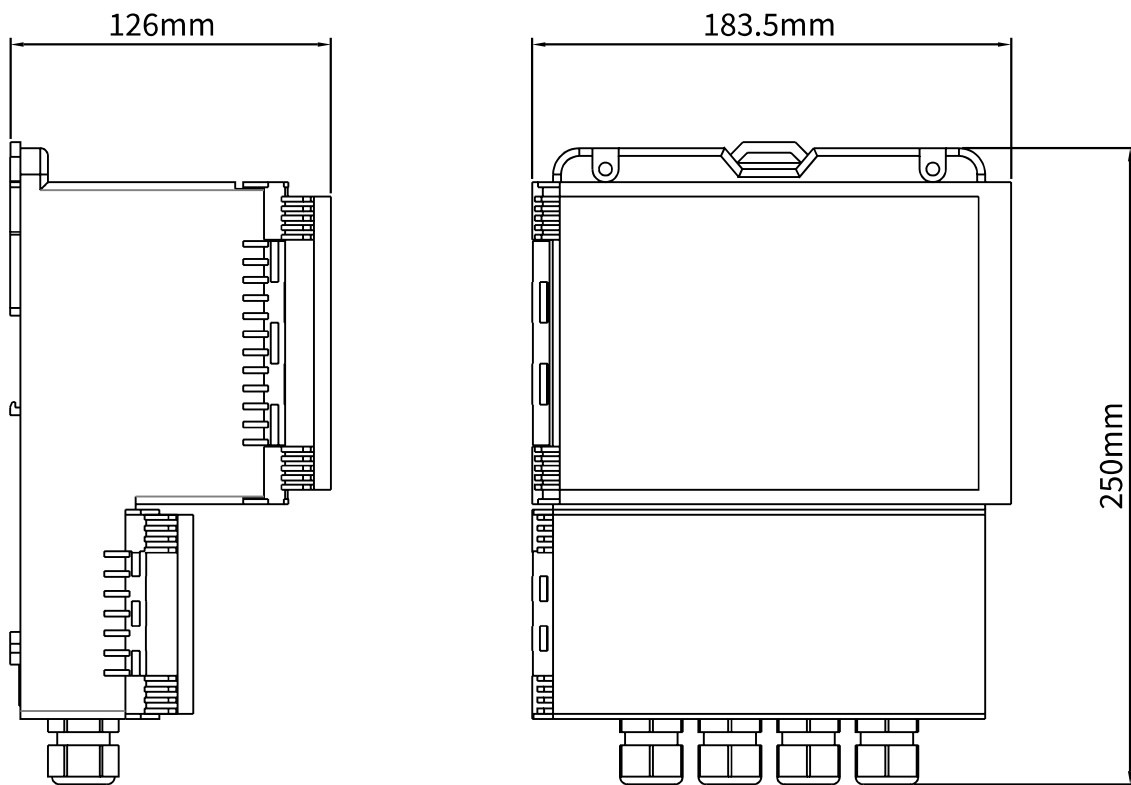

5-Installation

5.1 - PRECAUTIONS FOR INSTALLATION

- The installation must only be performed by qualified personnel and in compliance with the current regulations.
- Make sure that the operating temperature is between -20 and +60°C.
- Install the unit in an environment that is compatible with the physical characteristics and the construction materials of the casing; for outdoor installations, protect the unit from rain and sun with a protective roof.
- Incorrect use of the device could cause serious damage to persons, to the product and to the equipment connected to it.

5.1.1 - Wall assembly template

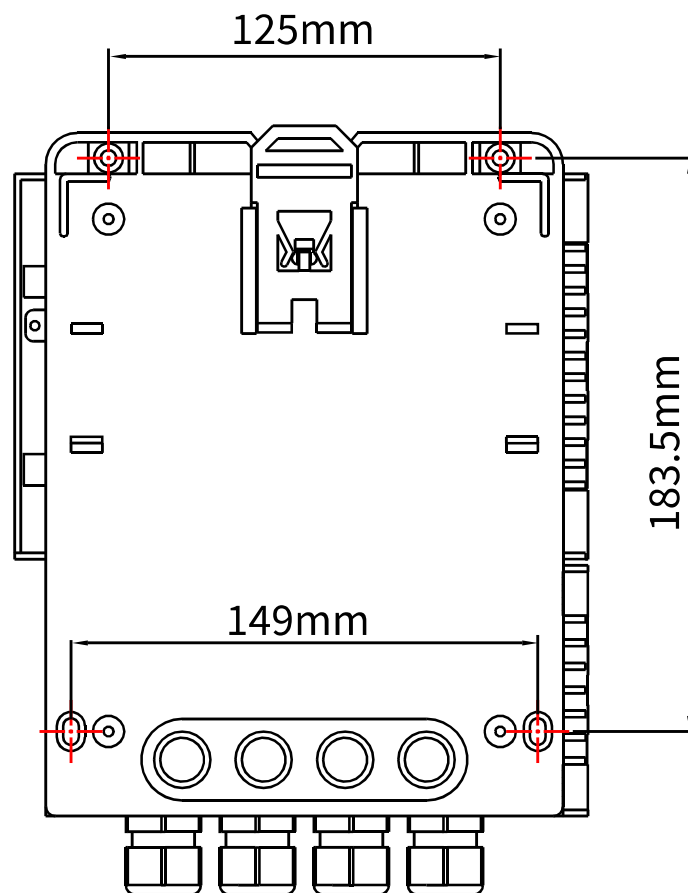

5.1.2 - Assembly on DIN bar

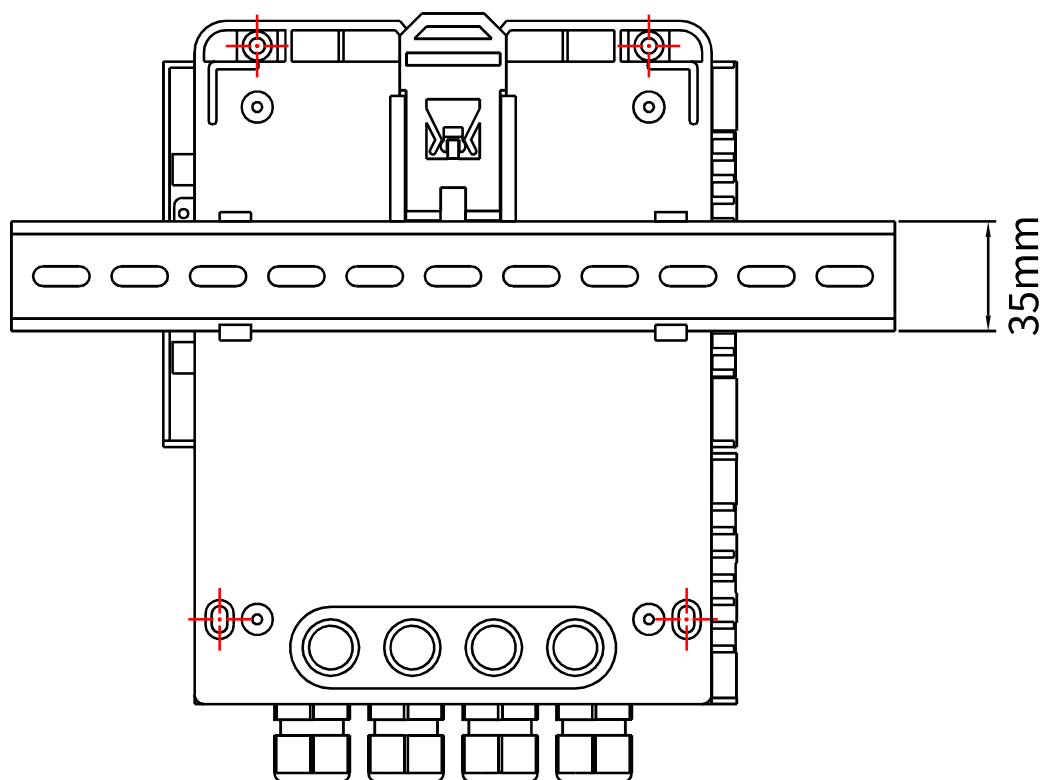

6-ELECTRICAL CONNECTION

6.1 - CONNECTIONS

- 1) Separate the motor or power control cables from the MCA800 connection cables.
- 2) Remove the caps from the cable glands and open the cover by loosening the appropriate screws.
- 3) Insert the cables into the transmitter through the cable glands.
- 4) Close the cover and tighten the cable glands.

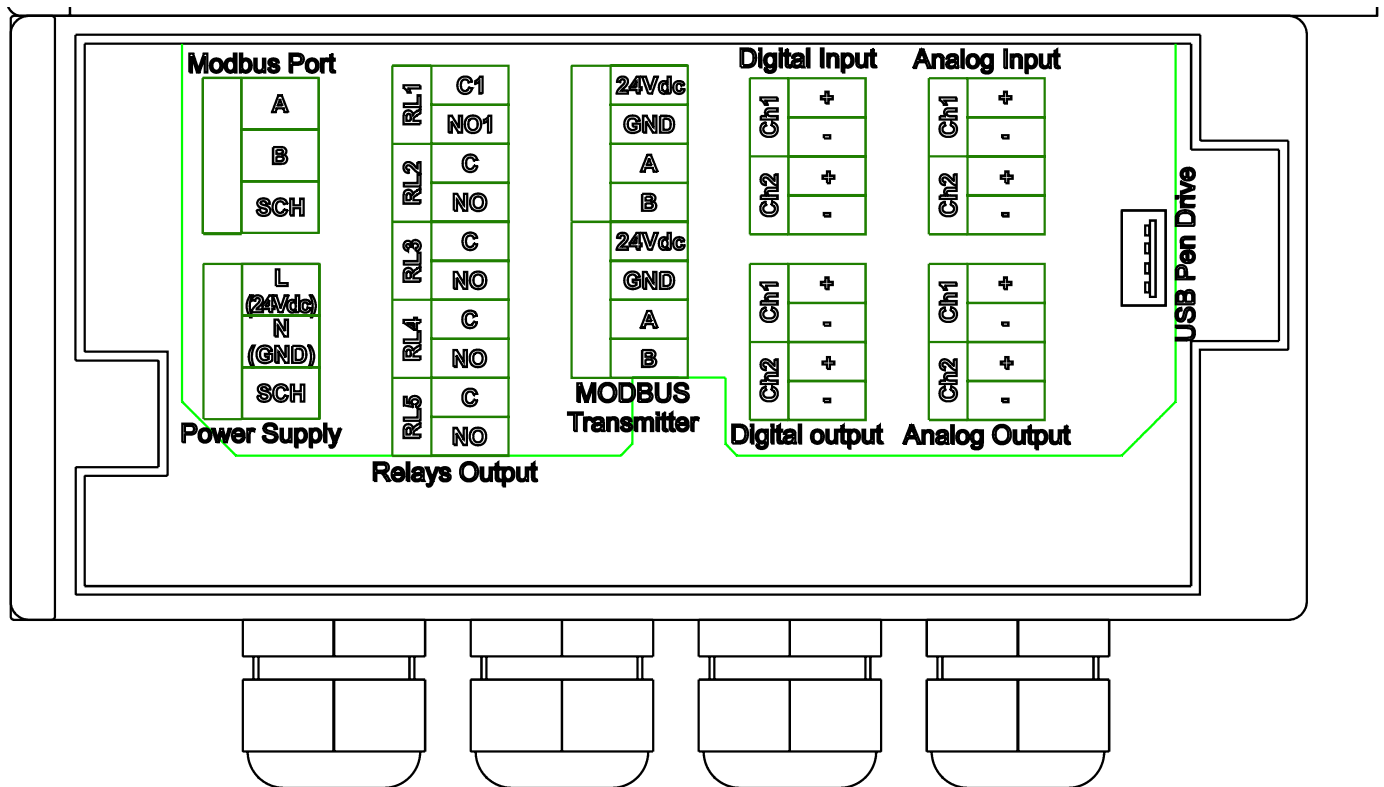

6.2 - INFILTRATIONS OF HUMIDITY

To avoid moisture infiltration inside the housing, the following steps are recommended:

- For the electrical connections use a cable with an external diameter of $6 \div 12$ mm and fully tighten the M20 cable gland.
- Close the lid tightly.
- Position the cable in such a way as to form a downward curve in the output of the M20 cable gland; in this way condensation and/or rainwater will tend to drip from the bottom of the curve.

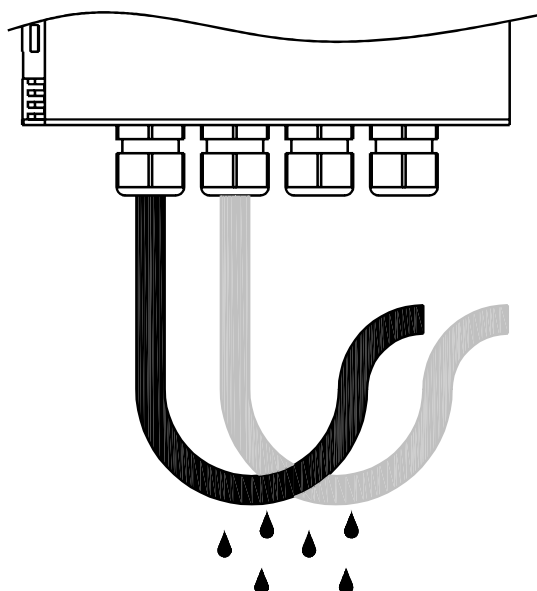

6.3 - SGM LEKTRA MODBUS TRANSMITTER CONNECTION

6.3.1 - MCA800 can directly power up to 2 analysis sensors.

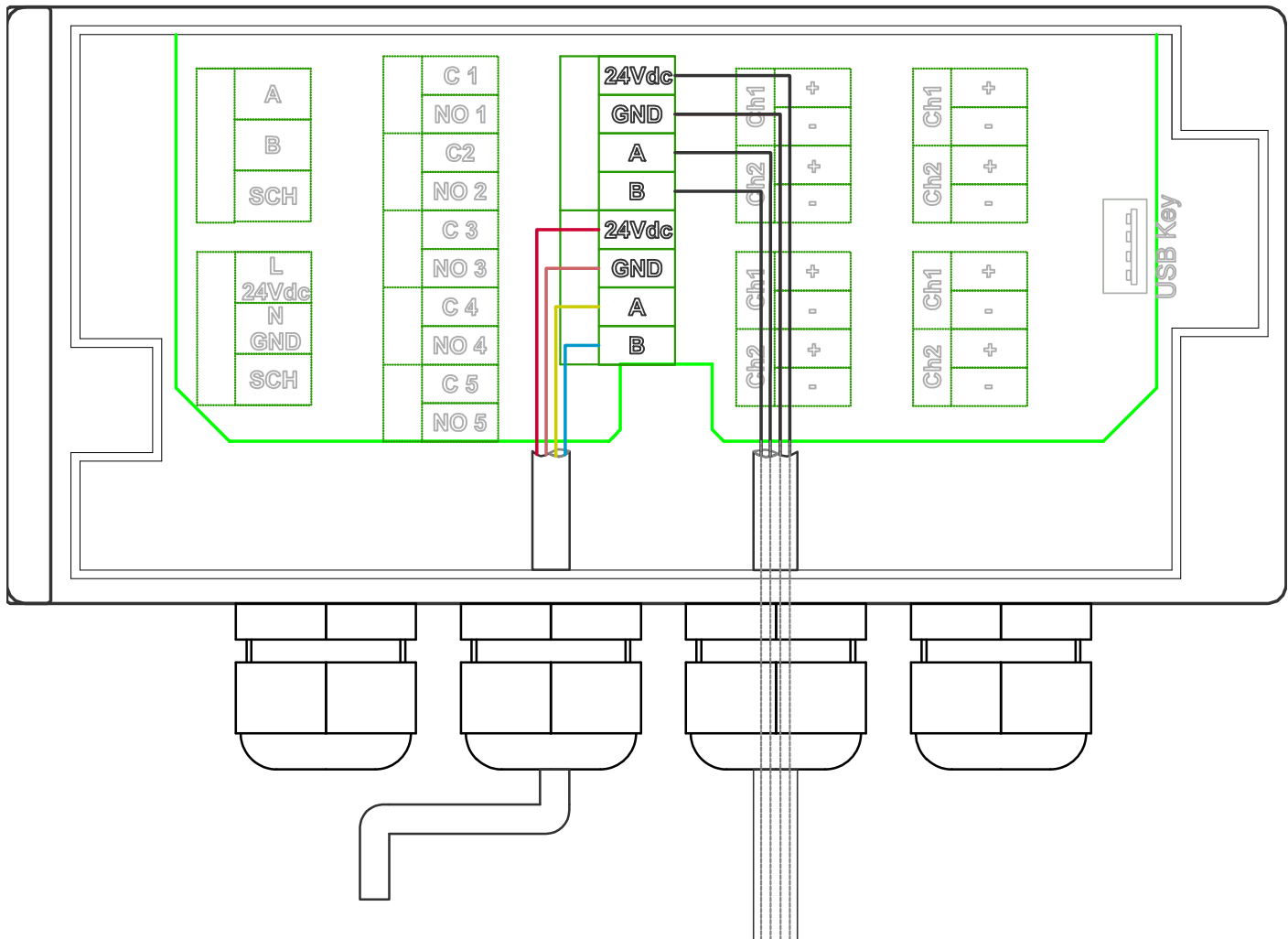

SENSOR CABLE TYPE "A"	
RED	+24Vdc
BLACK	GROUND
YELLOW	A
GREEN	B

SENSOR CABLE TYPE "B"	
BROWN	+24Vdc
WHITE	GROUND
BLACK	A
BLUE	B

Depending on the type of cable supplied with the analysis sensors, the colour sequence is either type "A" or type "B".





7-PROGRAMMING

7.1 - KEYBOARD

Opening the display cover, it is possible to access the 5 programming keys.

During the display of each single page of the menus, and of the programming parameters, the functions of the keys in that context are described.

MCA800 has a simple and easy to understand menu structure.

1. From "RUN" mode: press  to access the main menu
2. To select a programming menu use the arrow keys  a 
and confirm with the key .
3. To return to run mode, select from the main menu and press the key .

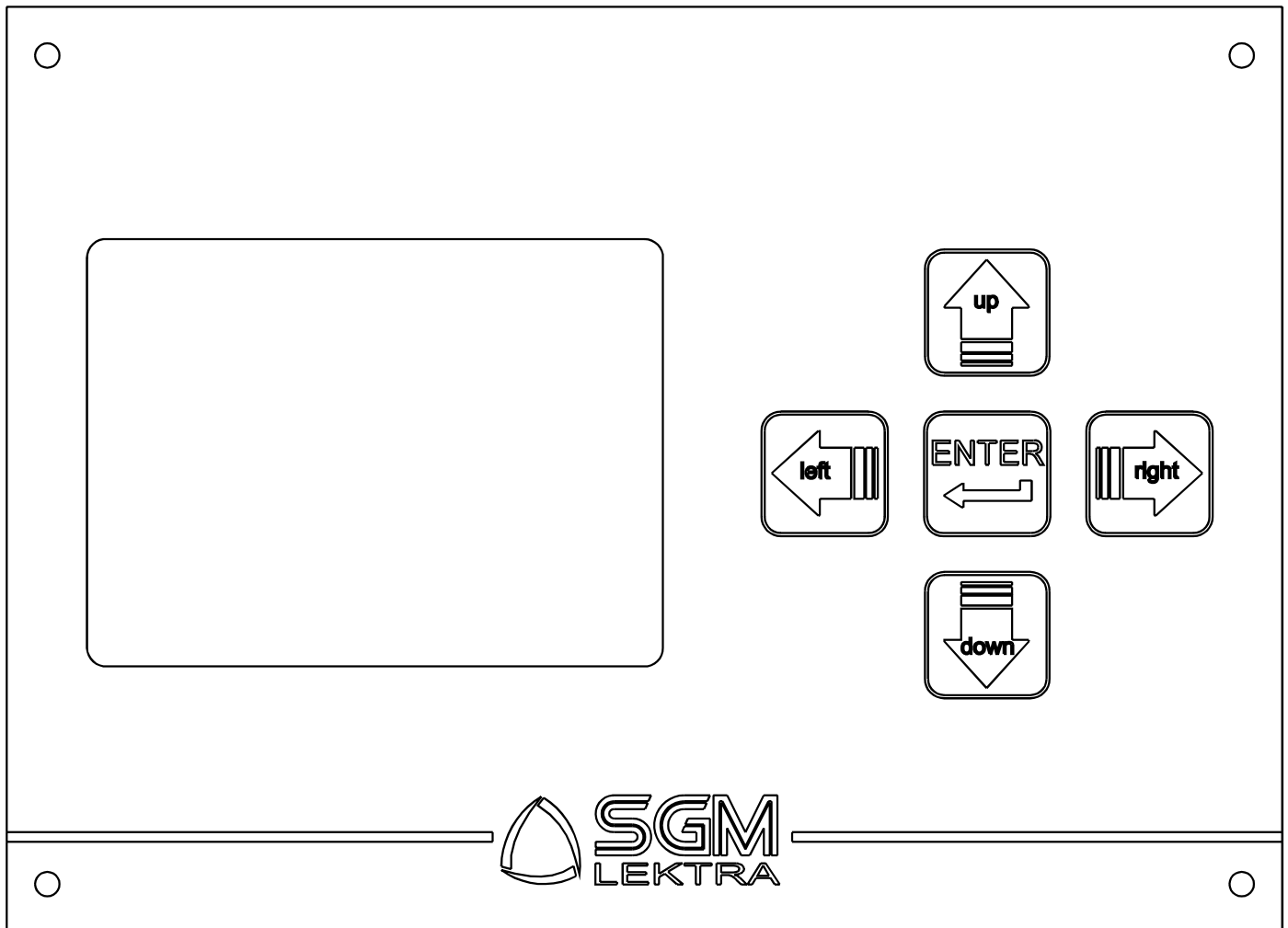

7.2 - CONFIGURATION MENU

INSTRUMENT SET-UP - Menu for the general configuration of the MCA800.

PROBE SET-UP - Menu for configuration of the sensors via MODBUS

OUTPUTS - Menu for configuration of the analog/digital output signals and of the 5 threshold relays.

INFO - MCA800 information menu.

7.3 - Power up and initialisation of the MCA800

When turned on, the MCA800 automatically starts the following system procedures:

- 1) Firmware upload for operational management of the MCA800 unit.
A green bar appears indicating the progress of the initialisation procedure.
- 2) Search for sensors connected via communication port MODBUS RTU (RS485). The following information is displayed:
 - a) * Probes Found: 2 ; shows the number of sensors with the correctly configured UID address, connected to the MCA800 unit.
 - b) UID1... UID2; shows the sensor model paired with its UID address.
In the example, 2 sensors are identified with their relative UID address and model.
MCA800 will automatically make the specific configuration menus of the connected sensors accessible.
- 3) Search Pen Drive of the data logger connected to the USB port.
 - a) * USB CONNECTED; indicates that the Pen Drive, FAT32-formatted, is connected to the USB port and the datalogger function is automatically enabled.
 - b) * USB NOT CONNECTED; indicates that no Pen Drive is connected to the USB port, or that the Pen Drive connected to the USB port is not FAT32-formatted; in this case it is necessary to connect the Pen Drive to a PC, or notebook, and perform the formatting by selecting the "FAT32" option in the "File system" item.
Then it is possible to connect the Pen Drive.

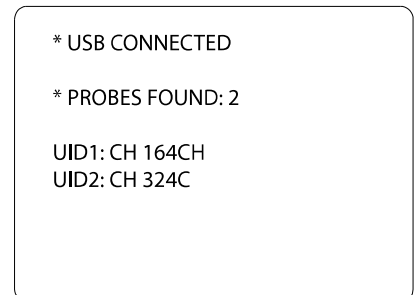

8-PH DIGITAL MEASUREMENT

8.1 - 104C PH ELECTRODE - DIGITAL MEASUREMENT WITH BUILT-IN TEMPERATURE SENSOR

The 104C sensor is used for the differential measurement of pH in pure waters, in waste water treatment plants, in processes with encrusting suspended solids, in processes with pollutants, in processes with high concentrations of sulphides, in coagulation and flocculation processes, in scrubbers, in galvanic processes, for surface finishes and in processes for the elimination or recovery of heavy metals

8.1.1 - APPLICATIONS

pH Measurement in:

- Purifiers and treatment of waste waters
- Coagulation and flocculation.
- Process monitoring and control.
- Acid/caustic effluent neutralisation system.

8.1.2 - CHARACTERISTICS AND ADVANTAGES

- Reliable pH measurement thanks to the use of a digital measuring process.
- Measurement communication via MODBUS RTU protocol.
- Possibility to perform all calibrations via serial port.
- Immediate installation and easy maintenance

The 104C pH electrode is suitable for pH measurements in a variety of applications.

The porous septum in liquid Teflon® is resistant to encrustations and chemical attack.

The double reference electrode increases the service life in applications containing sulphides (H₂S) and metals such as lead, mercury and silver.

The new reference “cast-in-place” electrolyte helps maintain a constant reference cell potential, resisting dilution over time with changes in pressure and temperature.

The new capillary temperature sensor design places the Pt100 sensor behind the pH sensitive membrane for very precise temperature measurement and compensation.

The IP68 environmental protection protects the high impedance signal of the pH electrode from moisture resulting from the condensation accumulated in the immersed pipes.

8.2 - SENSOR CALIBRATION

The calibration of the sensor must be performed:

- Upon start-up after a lengthy period of non-use
- Whenever there are discrepancies with respect to a known value

For a correct operation it will be necessary, in addition to the cases indicated above, to check the calibration or to recalibrate the probe periodically.

The frequency of this operation must be established by the user taking into account the type of application in which the probe operates and the type of electrode itself being used.

From the RUN menu of the instrument, press the left arrow to access the configuration menus; then scroll with the up or down arrow keys to select SET PROBE and press the right arrow then select "CH 104C UIDx" and press the right arrow, and finally select "CALIBRATION" and press the right arrow to access the 104C sensor calibration procedure.

Press ENTER when the measured value of the Ph is stable.

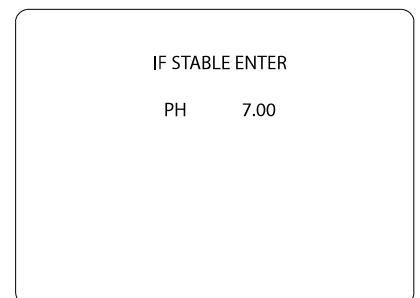

Enter the Ph value of the buffer solution used, or the value measured by the sample instrument.
Press ENTER to confirm.

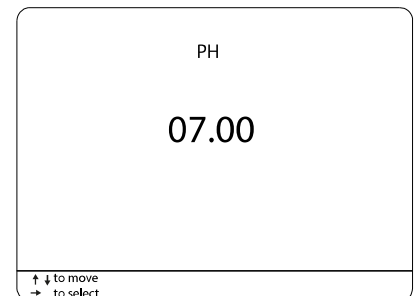

8.3 - CHARACTERISTICS AND DIMENSIONS

TECHNICAL SPECIFICATIONS	DIMENSIONS
Materials: - Body in Ryton® and PVC - O-Rings in Viton® - Other materials Teflon®, carbon, epoxy	
Measuring electrode: Hemispherical glass membrane	
Threading: 3/4" NPT, 3/4" BSP	
Measuring ranges: 0-14 pH	
Calibration method: calibration with certified standard pH solutions or sample instrument	
Measuring method: Digital	
Resolution: 0,01 pH	
Precision: ± 0.05 pH	
Repeatability: ± 0.05 pH	
Response time: T90<60s	
Temperature Probe: PT100	
Immersion operating temperature: 0÷50°C (122°F)	
Piping operating temperature: 0÷80°C	
Maximum operating pressure: 11 bar	
Minimum operating conductivity: 50µS	
Maximum absorption: 2W	
Mechanical protection: IP68 Sensor + cable	
Cable: 10m connected to the sensor (others on request)	
Power supply: 12...24Vdc	
Communication: RS485 Modbus	
Equipotential contact for solution: included	
Dimensions (LxHxD): 29x299x29mm	

8.4 - CONFIGURATION

Access the configuration menu by pressing the “LEFT” key.

Select PROBE SET-UP with “UP” or “DOWN and confirm with the“ RIGHT ”key.

N.B. – The composition of the PROBE SET-UP menu depends on the sensors connected to the MCA800. For example, if only probes 324C with UID 2 and 104C with UID 1 are connected to the MCA800, the menu would only consist of the lines “S: CH 324C UID2” and “S: CH 104C UID1”. The figure to the side shows a menu where the 104C sensor is preconfigured with the UID1 address

8.4.1 - S: CH 104C – PH

Select S : CH 104C UIDx and confirm with the “RIGHT” key.

8.4.1.1 - FILTER

Select FILTER and confirm with the “RIGHT” key.

Enter the filter value.
With “RIGHT” move the cursor and with “UP” modify the digit.
Confirm with “ENTER”.
Range: 0÷10
Default value: 05

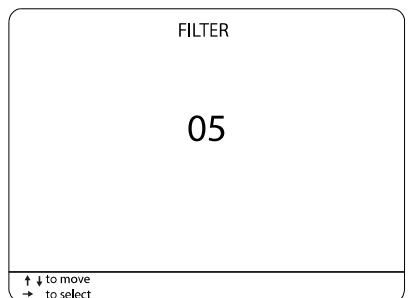
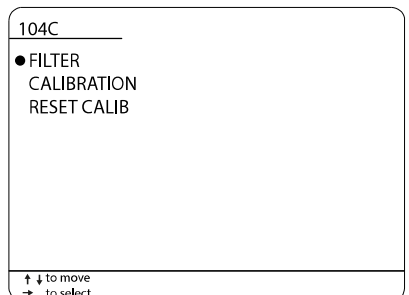
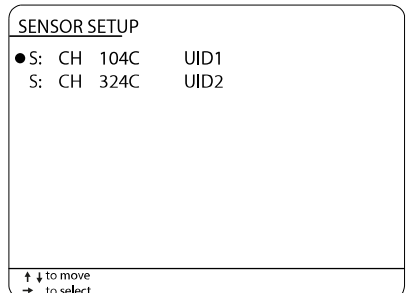
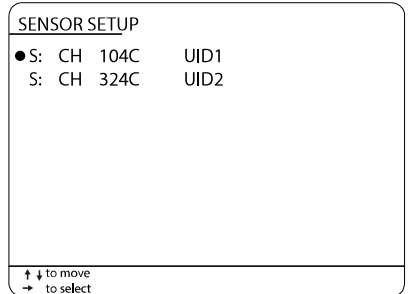
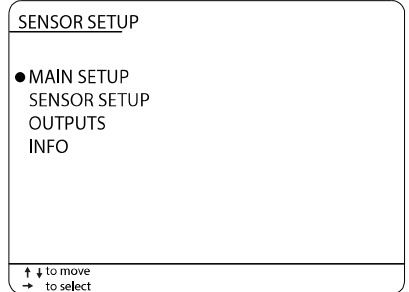

8.2.1.2 - CALIBRATION

Select CALIBRATION and confirm with the “RIGHT” key.

104C
FILTER
● CALIBRATION
CALIB RESET
↑ ↓ to move → to select

Press ENTER when the measured pH and temperature values are stable.

IF STABLE ENTER
PH 7.00

Enter the Ph value of the buffer solution used, or the value measured by the sample instrument.

Press ENTER to confirm.

PH
07.00
↑ ↓ to move → to select

8.2.1.3 - CALIB RESET

Select CALIB RESET and confirm with the “RIGHT” key.

104C
FILTER
CALIBRATION
● CALIB RESET
↑ ↓ to move → to select

Select YES to restore the factory sensor calibrations.
Select with the “UP” or “DOWN” keys.
Confirm the selection with the “RIGHT” key.

104C
● NO
SI
↑ ↓ per spostarsi → per selezionare

9-CONDUCTIVITY DIGITAL MEASUREMENT

9.1 - 114C - CONDUCTIVITY DIGITAL MEASUREMENT

Probe 114C is used for conductivity measurement in pure and process waters.

9.1.1 - APPLICATIONS

- Conductivity measurement in waste waters.
- Conductivity measurement in industrial and recirculating waters.

9.1.2 - CHARACTERISTICS AND ADVANTAGES

- Reliable conductivity measurement thanks to the use of graphite electrodes.
- Two-electrode conductive measuring method with temperature compensation.
- Sensor body in graphite electrodes PVC.
- Absence of mechanical moving parts.
- Immediate installation and easy maintenance.

9.2 - SENSOR CALIBRATION

The calibration of the sensor must be performed:

- upon start-up after a lengthy period of non-use.
- whenever there are discrepancies with respect to a known value.

For correct operation it will be necessary, in addition to the cases indicated above, to check the calibration or to recalibrate the probe periodically.

The frequency of this operation must be established by the user taking into account the type of application in which the probe operates and the type of electrode itself being used.

From the RUN menu of the instrument, press the left arrow to access the configuration menus; then scroll with the up or down arrow keys to select SET PROBE and press the right arrow then select "CH 114C UIDx" and press the right arrow, and finally select "CALIBRATION" and press the right arrow to access the 114C sensor calibration procedure.

Press ENTER when the measured conductivity and temperature values are stable.

CONDUCTIVITY:	0.0
TEMPERATURE	23.1
IF STABLE ENTER	

Enter the conductivity value of the buffer solution used, or the value measured by the sample instrument.
Press ENTER to confirm

CONDUCTIVITY:
00000
↑ ↓ to move → to select

9.3 - CHARACTERISTICS AND DIMENSIONS

TECHNICAL SPECIFICATIONS	DIMENSIONS
Materials: - PVC probe body - Graphite electrodes	
Threadings: 1" GAS BSP	
Measuring ranges: 0,00 to 20000uS	
Measuring method: two-electrode conductive	
Precision: +/-1uS	
Response: 90% of the value in less than 60 seconds	
Maximum refresh time: < 1 second	
Operating temperature: -10÷45 °C	
Maximum use pressure: 10 bar	
Maximum absorption: 2W	
Mechanical protection: IP68 Sensor+cable	
Cable: 10m connected to the sensor, others upon request	
Power supply: 12...24Vdc	
Signal interface: RS-485 Modbus RTU Protocol	
The probe is completely resin-coated inside	
Temperature Compensation: With optional internal NTC probe for the external version	
IP67 Connector: yes	

9.3.1 - HYDRAULIC INSTALLATION

The 114C probe can be supplied with the appropriate probe holder.



The 63mm diameter probe holder is available in various pipe lengths.

9.4 - CONFIGURATION

Access the configuration menu by pressing the “LEFT” key.

Select PROBE SET-UP with “UP” or “DOWN and confirm with the “ RIGHT ”key.

N.B. The composition of the PROBE SET-UP menu depends on the sensors connected to the MCA800. For example, if only probes 324C with UID 2 and 114C with UID 1 were connected to the MCA800, the menu would only consist of the lines “S: CH 324C UID2” and “S: CH 114C UID1”.

The figure to the side shows a menu where the 114C sensor is preconfigured with the UID1 address

9.4.1 - S: CH 114C – CONDUCTIVITY

Select S : CH 114C UIDx and confirm with the “RIGHT” key.

9.4.1.1 - FILTER

Select FILTER and confirm with the “RIGHT” key.

Enter the filter value.

With “RIGHT” move the cursor and with “UP” modify the digit.

Confirm with “ENTER.

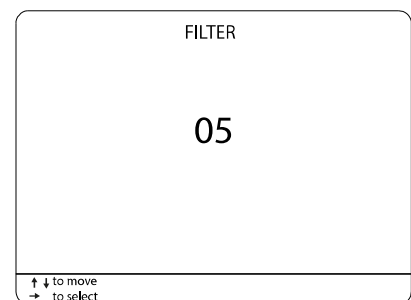
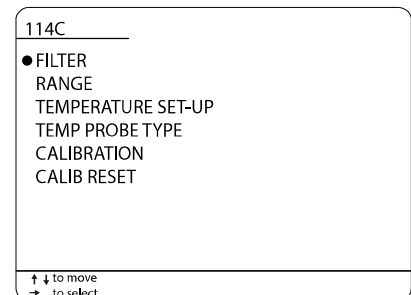
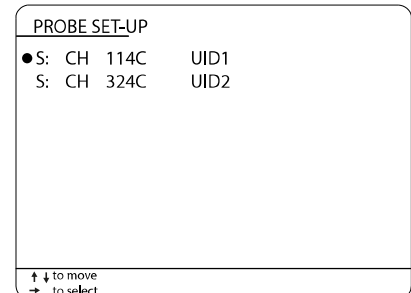
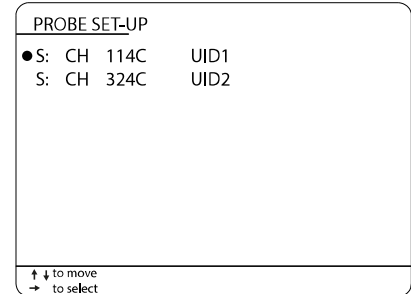
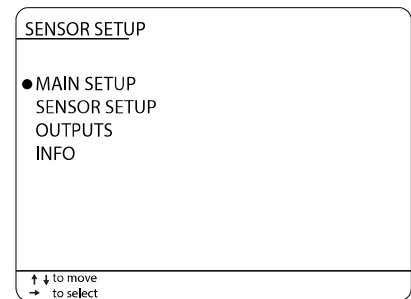

9.4.1.2 - RANGE

Select RANGE and confirm with the “RIGHT” key.

Select the measurement scale, expressed in micro Siemens, of the conductivity. With the “UP” or “DOWN” keys select the measurement scale. Confirm the selection with the “RIGHT” key.

9.4.1.3 - TEMPERATURE SET-UP

Select TEMPERATURE SETUP and confirm with the “RIGHT” key.

Select the AUTOMATIC mode (recommended) when the probe 114C has an integrated temperature sensor (internal or external). Select MANUAL mode. When the 114C probe does not have a built-in temperature sensor, MCA800 will automatically set the temperature to a fixed 25°C. Select the mode with the “UP” or “DOWN” keys. Confirm the selection with the “RIGHT” key.

9.4.1.4 - TEMP PROBE

Select TEMP PROBE TYPE and confirm with the “RIGHT” key.

Select the type of temperature sensor integrated with probe 114C. Select with the “UP” or “DOWN” keys. Confirm the selection with the “RIGHT” key.

CONDUCTIBILITY
FILTER ● RANGE TEMPERATURE SETUP TEMP PROBE TYPE CALIBRATION RESET CALIB
↑ ↓ to move → to select

RANGE
20µS ● 200µS 2000µS 200000µS
↑ ↓ to move → to select

CONDUCTIBILITY
FILTER RANGE ● TEMPERATURE SETUP TEMP PROBE TYPE CALIBRATION CALIB RESET
↑ ↓ to move → to select

TEMPERATURE SETUP
● AUTOMATIC MANUAL
↑ ↓ to move → to select

CONDUCTIBILITY
FILTER RANGE TEMPERATURE SETUP ● TEMP PROBE TYPE CALIBRATION CALIB RESET
↑ ↓ to move → to select

TEMP PROBE TYPE
● NTC PT100 PT1000
↑ ↓ to move → to select

9.4.1.5 - CALIBRATION

Select CALIBRATION and confirm with the “RIGHT” key.

CONDUCTIBILITY	
FILTER	
RANGE	
TEMPERATURE SETUP	
TEMP PROBE TYPE	
● CALIBRATION	
CALIB RESET	

↑ ↓ to move
→ to select

Press ENTER when the measured conductivity and temperature values are stable.

CONDUCTIVITY:	0.0
TEMPERATURE	23.1
IF STABLE ENTER	

Enter the conductivity value of the buffer solution used, or the value measured by the sample instrument.
Press ENTER to confirm

CONDUCTIVITY:
00000

↑ ↓ to move
→ to select

9.4.1.6 - CALIB RESET

Select CALIB RESET and confirm with the “RIGHT” key.

CONDUCTIBILITY	
FILTER	
RANGE	
TEMPERATURE SETUP	
TEMP PROBE TYPE	
CALIBRATION	
● CALIB RESET	

↑ ↓ to move
→ to select

Select YES to restore the factory sensor calibrations.
Select with the “UP” or “DOWN” keys.
Confirm the selection with the “RIGHT” key.

CALIB RESET	
● NO	
YES	

↑ ↓ to move
→ to select

10-DISSOLVED OXYGEN OPTICAL MEASUREMENT

10.1 - 324C -DISSOLVED OXYGEN OPTICAL MEASUREMENT

The 324C probe is used for the optical measurement of oxygen in pure and process waters. The measuring principle is based on the dynamic reduction of luminescence by molecular oxygen.

10.1.1 - APPLICATIONS

- Measurement of oxygen in waste waters.
- Measurement of oxygen in primary, industrial and

10.1.2 - CHARACTERISTICS AND ADVANTAGES

- Reliable concentration measurement thanks to the use of an optical measuring process.
- Dynamic luminescence measuring method.
- Sensor body in AISI316 or black PVC
- Interchangeable cap for luminophore replacement.
- Absence of mechanical moving parts.
- Immediate installation and easy maintenance.
- Ability to set salinity and atmospheric pressure to compensate for the oxygen value.

10.1.3 - OPERATING PRINCIPLE

The luminophore in a state of excitation in contact with its damper (oxygen) loses its ability to reflect light; this phenomenon is called collisional or dynamic quenching.

After the collision there is a transfer of energy from the excited molecule to the oxygen, which passes from its ground state (triplet) to its excited state (singlet).

Consequently, the indicator molecule does not emit luminescence and the measurable luminescence signal itself decreases.

There is therefore a relationship between oxygen concentration and intensity and duration of luminescence; it is expressed by the Stern-Volmer equation (1). τ_0 and τ are the luminescence decay times respectively in the absence and in the presence of O₂ (I_0 and I are the respective luminescence intensities), [O₂] is the oxygen concentration, while KSV is the quenching constant.

10.1.4 - Principle of the dynamic luminescence :

$$I_0/I = \tau_0/\tau = 1 + K_{sv} \cdot O_2$$

$$I = f(O_2) \quad \tau = f(O_2)$$

Where:

I : Intensity of luminescence in the presence of oxygen

I_0 : Intensity of luminescence in the absence of oxygen

τ : Luminescence decay time in the presence of oxygen

τ_0 : Luminescence decay time in the absence of oxygen

KSV: Stern-Volmer constant (quantifies the quenching efficiency and therefore the sensitivity of sensor)

[O₂]: Concentration of Oxygen

Principle of dynamic reduction of luminescence by molecular oxygen

(1) Luminescence process in the absence of O₂

(2) Deactivation of the luminescent molecule by oxygen

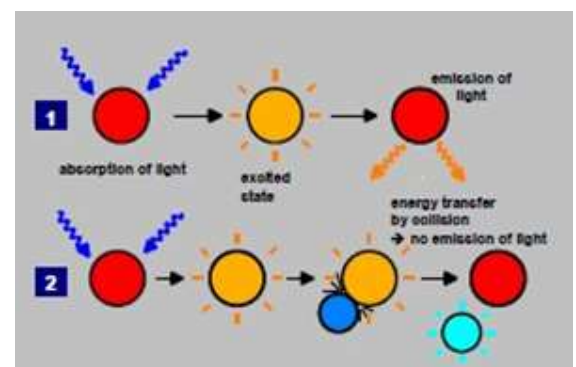

10.2 - CHARACTERISTICS AND DIMENSIONS

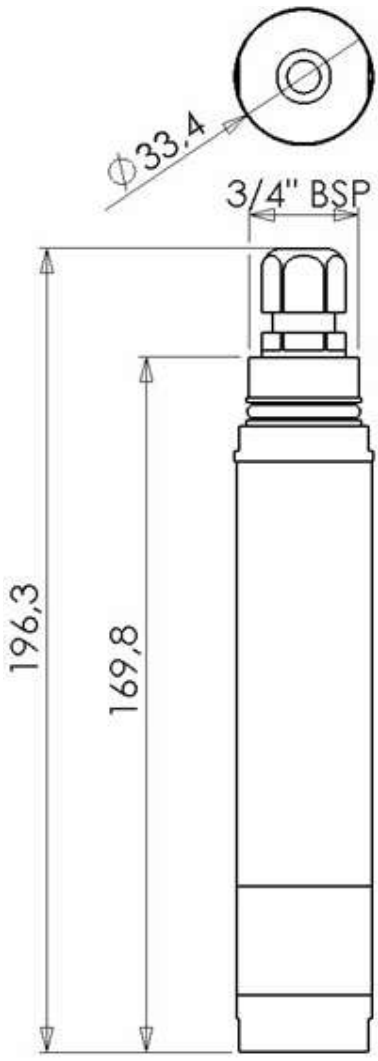
TECHNICAL	DIMENSIONS
Materials: - Probe body in AISI 316 (optional PVC body) - Special optical glasses - NBR and Silicone O-Rings	
Threading: 3/4" BSP	
Measuring ranges: from 0.00 mg/L to 20.00 mg/L	
Measuring method: Optical luminescence measurement	
Calibration method: -calibration in air: 1-point calibration, 100% oxygen-saturated water -calibration with sample: comparison with a standard instrument -calibration on 0% solution of O₂: 1 point calibration, specific solution at 0% of oxygen	
Precision: ± 0,2 mg/L quando < 5mg/L ± 0,3 mg/L quando > 5mg/L	
Resolution: 0,01 mg/L	
Repeatability: ± 0,1 mg/L	
Response: T90<60s	
Maximum refresh time: < 1 second	
Operating temperature: 0÷50°C precision ± 0.2°C	
Maximum use pressure: 5 bar	
Maximum absorption: 2W	
Mechanical protection: IP68 Sensor+cable	
Cable: 10m connected to the sensor (others on request)	
Power supply: 12...24Vdc	
Signal interface: RS-485 Modbus RTU Protocol	
Movement of the water: Not necessary	
Temperature Compensation: With inner NTC probe	
Luminophore diameter: 10mm	
IP67 Connector: yes	

10.2.3 - HYDRAULIC INSTALLATION

The 324C probe can be supplied with the appropriate probe holder, available in various pipe lengths.

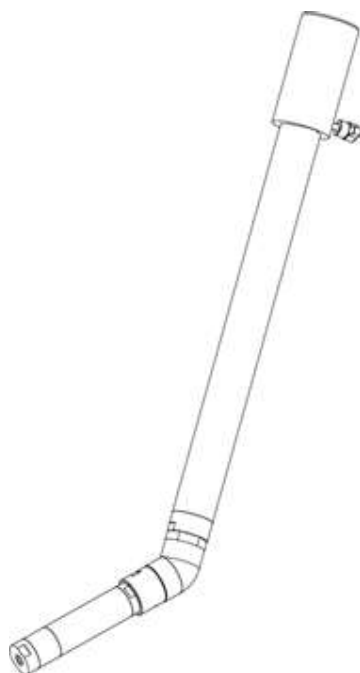

A 45° inclination device for the probe is supplied together with the probe holder; this device must always be used. It is also possible to equip the assembly with a swivel system that guarantees the possibility of obtaining almost any configuration, as well as ensuring easier cleaning and maintenance of the system (figure below).



10.3 - SENSOR CALIBRATION

The calibration must necessarily be performed:

- Each time the sensor cap is replaced.
- Upon start-up after a lengthy period of non-use.
- Whenever there are discrepancies with respect to a known value.

For correct operation it will be necessary, in addition to the cases indicated above, to check the calibration or to recalibrate the probe periodically.

The frequency of this operation must be established by the user taking into account the type of application and the type of electrode used.

NOTE

To perform a calibration in saturated solution, immerse the oxygen probe in a container of clean water and wait 10 minutes for stabilisation. Then continue with the automatic calibration.

From the RUN menu of the instrument, press the left arrow to access the configuration menus; then scroll with the up or down arrow keys to select SET PROBE and press the right arrow then select "CH 324C UIDx" and press the right arrow, and finally select "CALIBRATION" and press the right arrow to access the 324C sensor calibration procedure.

10.3.1 - CAL 100% AIR

Select CAL 100% AIR and confirm with the "RIGHT" key.
To perform the calibration correctly, it is necessary to position the probe completely in the air.

Select YES to perform the calibration.
Select with the "UP" or "DOWN" keys.
Confirm the selection with the "RIGHT" key.

10.3.2 - 0% AIR SAT

Select 0% AIR SAT and confirm with the "RIGHT" key.
To perform the calibration correctly, it is necessary to position the probe in water without dissolved oxygen.

Select YES to perform the calibration.
Select with the "UP" or "DOWN" keys.
Confirm the selection with the "RIGHT" key

324C

PRESSURE SET-UP
SALINITY SET-UP
● CAL 100% AIR
0% AIR SAT

↑ ↓ to move
→ to select

CAL 100% AIR

● NO
YES

↑ ↓ to move
→ to select

324C

PRESSURE SET-UP
SALINITY SET-UP
CAL 100% AIR
● 0% AIR SAT

↑ ↓ to move
→ to select

0% AIR SAT

● NO
YES

↑ ↓ to move
→ to select

10.3.3 - PRECAUTIONS AND MEASURES

Before installation, remove the black rubber protective cap. Attention: it is advisable not to remove the interchangeable probe cap at all unless there is a malfunction of the probe itself due to the luminophore and therefore it is not necessary to replace the glass containing the polymer (see figure below):



In addition, it is necessary to pay particular attention to the substances with which the part of the probe used for measurement may come into contact: for example, organic acids such as acetic acid do not damage the sensor. However, avoid exposure of the luminophore to organic solvents such as acetone, chloroform, benzene and toluene. Chlorine gas can actually destroy the sensor or otherwise distort the measurement.

Replacement of the luminophore cap must be performed when the measurements are not reliable even after a calibration.

If the black surface of the luminophore shows signs of damage, it is necessary to change the cap.

Also pay particular attention to the formation of air bubbles: they could interfere with the oxygen reading.

To overcome this problem, mount the probe inclination kit at 45°, to ensure that the bubbles slide upwards.

10.4 - CONFIGURATION

Access the configuration menu by pressing the “LEFT” key.

Select PROBE SETUP with “UP” or “DOWN and confirm with the“ RIGHT ”key.

N.B. – The composition of the PROBE SETUP menu depends on the sensors connected to the MCA800. For example, if only probes 324C with UID 1 and 114C with UID 2 are connected to the MCA800, the menu would only consist of the lines “S: CH 324C UID2” and “S: CH 114C UID1”. The figure to the side shows a menu where the 324C sensor is preconfigured with the UID2 address

10.4.1 - DISSOLVED OXYGEN OPTICAL MEASUREMENT

Select S : CH 324C UIDx and confirm with the “RIGHT” key.

10.4.1.1 - PRESSURE SETUP

Select PRESSURE SETUP and confirm with the “RIGHT” key.

Enter the atmospheric pressure value expressed in mbar.
With “RIGHT” move the cursor and with “UP” modify the digit.
Confirm with “ENTER.

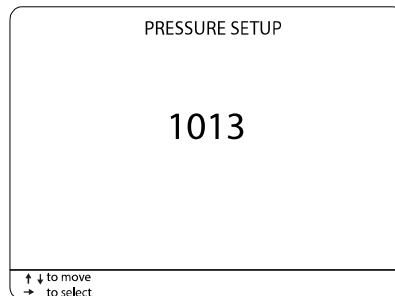
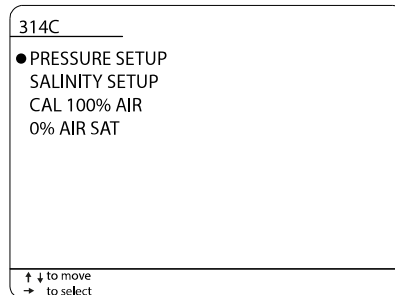
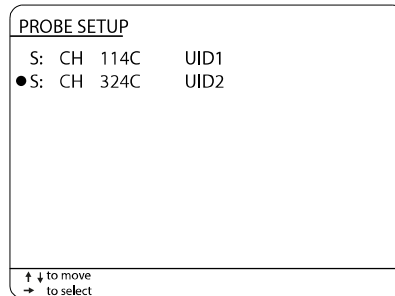
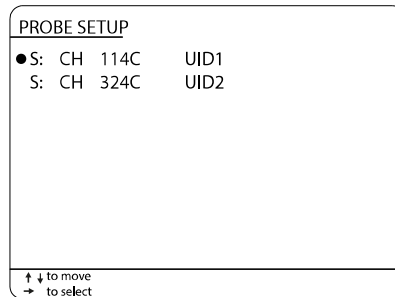
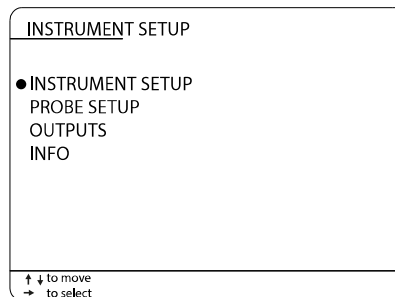

10.4.1.2 - SALINITY SETUP

Select SALINITY SETUP and confirm with the “RIGHT” key.

Enter the salinity value expressed in g/Kg.
With “RIGHT” move the cursor and with “UP” modify the digit.
Confirm with “ENTER.

10.4.1.3 - CAL 100% AIR

Select CAL 100% AIR and confirm with the “RIGHT” key.

To perform the calibration correctly, it is necessary to position the probe completely in the air.

Select YES to perform the calibration.

Select with the “UP” or “DOWN” keys.
Confirm the selection with the “RIGHT” key.

10.4.1.4 - 0% AIR SAT

Select 0% AIR SAT and confirm with the “RIGHT” key.

To perform the calibration correctly, it is necessary to position the probe in water without dissolved oxygen.

Select YES to perform the calibration.

Select with the “UP” or “DOWN” keys.
Confirm the selection with the “RIGHT” key

324C
PRESSURE SETUP <input checked="" type="radio"/> SALINITY SETUP CAL 100% AIR 0% AIR SAT
↑ ↓ to move → to select

SALINITY SET-UP
0000
↑ ↓ to move → to select

324C
PRESSURE SETUP SALINITY SETUP <input checked="" type="radio"/> CAL 100% AIR 0% AIR SAT
↑ ↓ to move → to select

CAL 100% AIR
<input checked="" type="radio"/> NO YES
↑ ↓ to move → to select

324C
PRESSURE SETUP SALINITY SETUP CAL 100% AIR <input checked="" type="radio"/> 0% AIR SAT
↑ ↓ to move → to select

0% AIR SAT
<input checked="" type="radio"/> NO YES
↑ ↓ to move → to select

11-INFRA-RED TURBIDITY MEASUREMENT

11.1 - 164CL - Infrared turbidity measurement

The 164CL sensor is used for optical turbidity measurement in pure and process waters up to 100 NTU. The probe uses the 90° light scattering measuring method.

11.1.1 - APPLICATIONS

- Measurement of turbidity in pure and drinking waters.
- Turbidity measurement in primary, industrial and recirculating.

11.1.2 - CHARACTERISTICS AND ADVANTAGES

- Reliable concentration measurement thanks to the use of an optical measuring process.
- Pulsed infrared light beam scattering method.
- Black rigid PVC sensor body.
- Absence of mechanical moving parts.
- Pre-processed measurement in the sensor that provides high sensitivity in the low signal transmission.

11.1.3 - MEASUREMENT OF TURBIDITY WITH THE 90° LIGHT SCATTERING METHOD

Turbidity refers to the dispersed component of a beam of light that is deflected from its natural path through the impact with denser particles present in the medium (e.g. solid particles).

The measurement is performed using 90° light scattering, according to the ISO 7027 / EN 27027 standard. The measuring method is based on the Tyndall effect.

The turbidity of the medium is determined by the amount of scattered light.

The transmitted infrared light beam is “scattered” by the particles present in the medium.

The “scattered” light beams are detected and processed by photo-receivers placed at an angle of 90° with respect to the directrix of the transmitted light beam.

The signals due to the “scattered” light are then converted into frequency signals’ which are assigned to corresponding turbidity values and are thus shown on the display.

Principle of 90° light scattering measurement

$$I_s = I_0 \cdot A \cdot C \cdot f(\alpha)$$

Where:

I_0 = Intensity of the transmitted light

I_s = Intensity of the scattered light

A = Geometric factor

C = Molar concentration

$f(\alpha)$ = Angular correlation

P = Particle

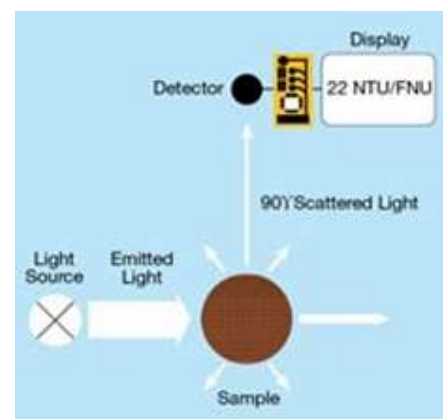

11.2 - CHARACTERISTICS AND DIMENSIONS

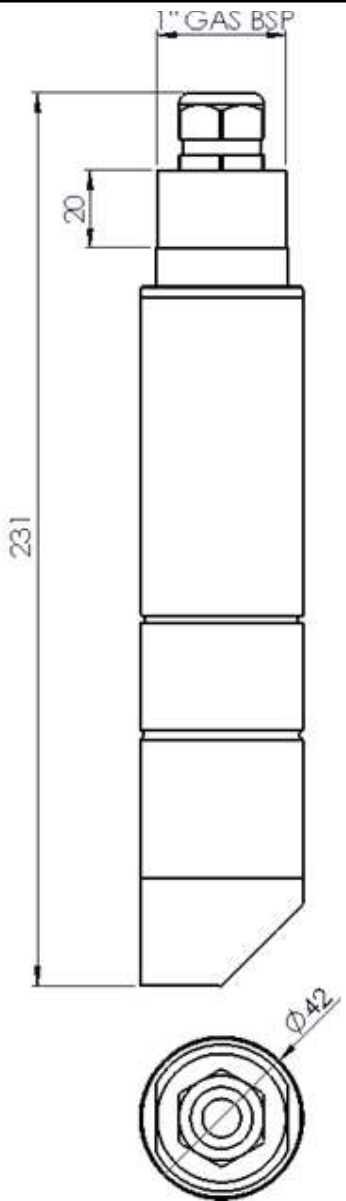
TECHNICAL	DIMENSIONS
Materials: - Black PVC body - Special glass optic with oleophobic treatment - Viton and Silicone OR	 <p>1" GAS BSP</p> <p>20</p> <p>231</p> <p>Ø42</p>
Threading: 1" GAS	
Measuring ranges: from 0.00 mg/L to 20.00 mg/L	
Measuring ranges: - 0-10NTU - 0-100NTU	
Measuring method: 90° scattering	
Resolution: - 0,01 NTU range 0-10NTU (0.001NTU fino a 9,999NTU) - 0,1 NTU range 0-100NTU	
Precision: - ±1% on the measuring point_range 0-10NTU - ±2% on the measuring point_range 0-50NTU - ±5% on the measuring point_range 0-100NTU	
Repeatability: - ±0.05 NTU f.s 10NTU - ±0.5 NTU f.s 100NTU	
Calibration: 1 point	
Response time: T ₉₀ <60s	
Operating temperature: 0÷50 °C	
Maximum operating pressure: 4 bar	
Mechanical protection: IP68 Sensor+cable	
Cable length: 10m connected to the sensor (other on request)	
Power supply: 12...24Vdc	
Max Absorption: 3W	
Outputs: RS485 (4-20mA optional)	

11.2.1 - PROBE CALIBRATION

Single point:

This calibration mode is used to change the offset of the entire line and must only be performed when the turbidity value of the point we are calibrating is above 1 NTU, because the probe does not allow changing of the offset if the turbidity values are too low.

Circulate water with a known solution, making sure that there are no air bubbles in the circuit: to eliminate them, a slight back pressure can be created by partially closing the outlet flow.

The liquid can also stay still inside the probe-holder, but be careful of deposit phenomena that could distort the reading. Wait approximately 4-5 minutes for the value to stabilise and proceed with the calibration by entering the value of the known solution from the keyboard.

11.2.2 - INSTALLATION IN TANK OR CISTERN

Install the probe inside the tank so that it is immersed by at least 20 cm and so that the distance from the walls and bottom of the tank itself is not less than 20 cm.

From the RUN menu of the instrument, press the left arrow to access the configuration menus; then scroll with the up or down arrow keys to select PROBE SET-UP and press the arrow to the right then select "CH 164CL UIDx" and press the right arrow, and finally select "CALIBRATION" and press the right arrow to access the 164CL sensor calibration procedure.

Select TURBIDITY CAL. and confirm with the "RIGHT" key.

Enter the known turbidity value.

With "RIGHT" move the cursor and with "UP" modify the digit. Confirm with "ENTER".

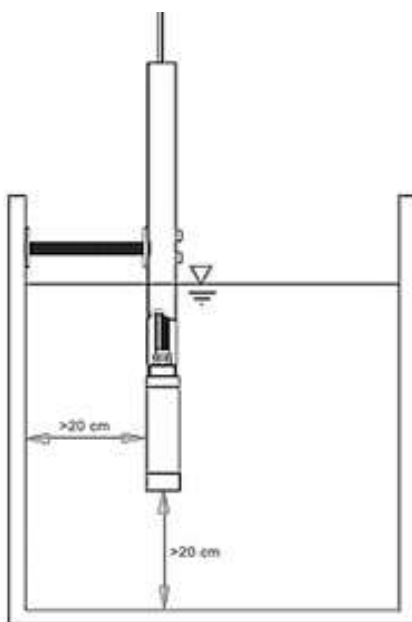
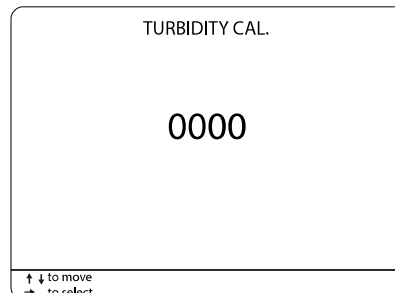
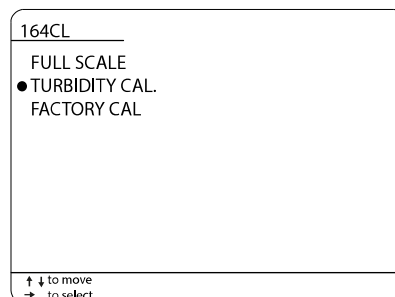

11.2.3 - CHANNEL INSTALLATION

Also in this case, install the probe inside the channel so that it is immersed by at least 20 cm and so that the distance from the walls and the bottom of the tank itself is not less than 20 cm.

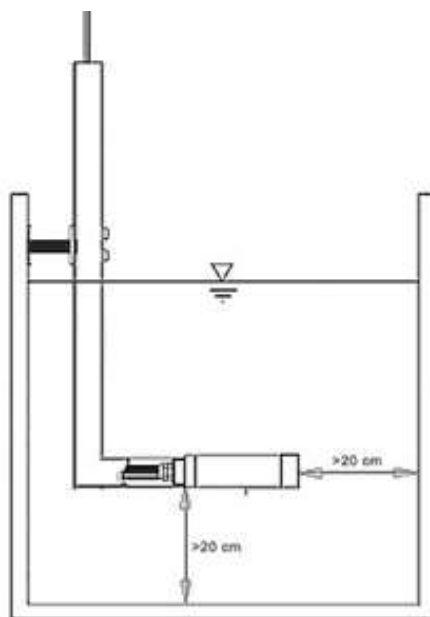

11.2.4 - BYPASS INSTALLATION

Install the probe inside the beaker as indicated in the figure below.

To facilitate the correct insertion, a warning label is placed on the probe body indicating the direction of flow.

When the probe is installed, the calibration curve must be modified to compensate for the offset of the probe holder wall.

ATTENTION!!! each bypass probe holder has its own intrinsic structure which could slightly interfere with the reading, so each probe + probe-holder system must be calibrated together.

It is advisable to install an outlet tap to reduce the flow and thus create inside the probe holder a pressure that is able to promote the elimination of any air bubbles.

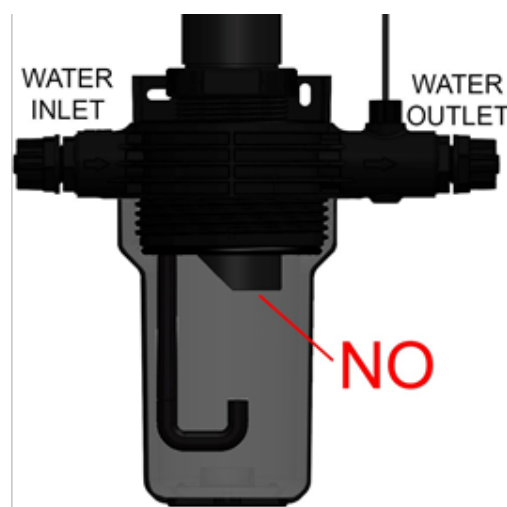
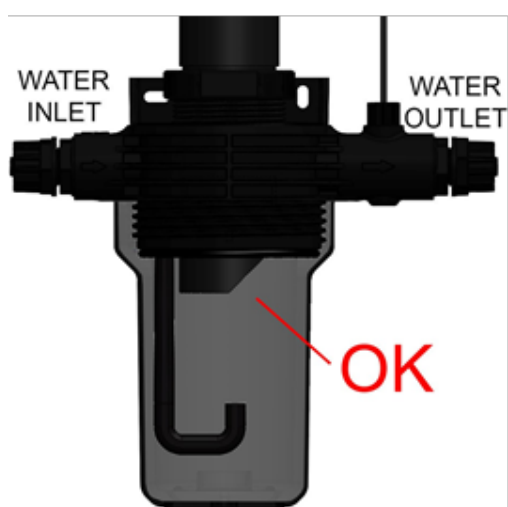

11.2.5 - ANCHOR DEVICES ON THE TANK

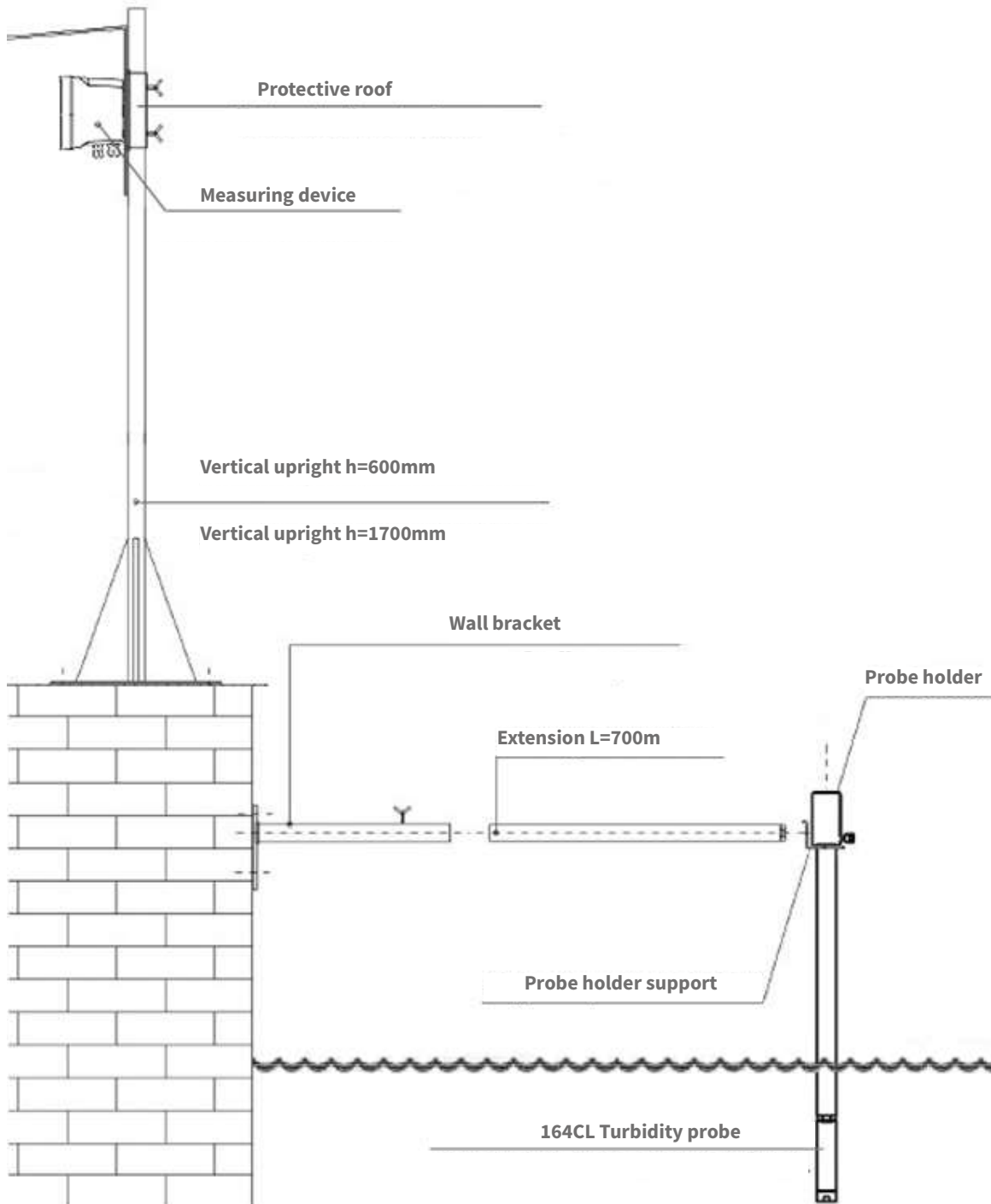

11.3 - CONFIGURATION

Access the configuration menu by pressing the “LEFT” key.

Select PROBE SET-UP with “UP” or “DOWN” and confirm with the “RIGHT” key.

N.B. – The composition of the PROBE SET-UP menu depends on the sensors connected to the MCA800.

For example, if only probes 324C with UID 2 and 164CL with UID 1 are connected to the MCA800, the menu would only consist of the lines “S: CH 324C UID2” and “S: CH 164CL UID1”.

The figure to the side shows a menu where the 164CL sensor is preconfigured with the UID1 address.

11.3.1 - 1164CL – INFRARED TURBIDITY MEASUREMENT

Select S : CH 164CL UIDx and confirm with the “RIGHT” key.

11.3.1.1 - FULL SCALE

Select FULL SCALE and confirm with the “RIGHT” key.

Select the full scale value.

Select with the “UP” or “DOWN” keys.

Confirm the selection with the “RIGHT” key.

INSTRUMENT SET-UP	
INSTRUMENT SET-UP	
●	PROBE SET-UP
	OUTPUTS
	INFO
↑ ↓ to move → to select	

PROBE SET-UP	
●	S: CH 164CL UID1
	S: CH 324C UID2
↑ ↓ to move → to select	

PROBE SET-UP	
●	S: CH 164CL UID1
	S: CH 324C UID2
↑ ↓ to move → to select	

164CL	
●	FULL SCALE
	TURBIDITY CAL.
	FACTORY CAL.
↑ ↓ to move → to select	

FULL SCALE	
●	10 NTU
	100 NTU
↑ ↓ to move → to select	

11.3.1.2 - TURBIDITY CAL.

Select TURBIDITY CAL. and confirm with the “RIGHT” key.

164CL
FULL SCALE ● TURBIDITY CAL. FACTORY CAL.
↑ ↓ to move → to select

Enter the known turbidity value.
With “RIGHT” move the cursor and with “UP” modify the digit.
Confirm with “ENTER”.

TURBIDITY CAL.
0000
↑ ↓ to move → to select

11.3.1.3 - FACTORY CAL

Select FACTORY CAL.

164CL
FULL SCALE TURBIDITY CAL. ● FACTORY CAL.
↑ ↓ to move → to select

Select YES to restore the factory calibrations.
Select with the “UP” or “DOWN” keys.
Confirm the selection with the “RIGHT” key

ARE YOU SURE?
● NO YES
↑ ↓ to move → to select

12-INFRA-RED HIGH TURBIDITY MEASUREMENT

12.1 - 164CH - Infrared high turbidity

The 164CH sensor is used for optical turbidity measurement in pure and process waters up to 1000 NTU or 4000NTU. The probe uses the 90° light scattering measuring method.

12.1.1 - APPLICATIONS

- Measurement of turbidity in pure and drinking waters.
- Turbidity measurement in primary, industrial and recirculating.

12.1.2 - CHARACTERISTICS AND ADVANTAGES

- Reliable concentration measurement thanks to the use of an optical measuring process.
- Pulsed infra-red light beam scattering method.
- Sensor body in SS316 and rigid black PVC (optional only AISI 316 or only PVC).
- Absence of mechanical moving parts.
- Pre-processed measurement in the sensor that provides high sensitivity in the low signal transmission.

12.1.3 - MEASUREMENT OF TURBIDITY WITH THE 90° LIGHT SCATTERING METHOD

Turbidity refers to the dispersed component of a beam of light that is deflected from its natural path through the impact with denser particles present in the medium (e.g. solid particles).

The measurement is performed using 90° light scattering, according to the ISO 7027 / EN 27027 standard.

The measuring method is based on the Tyndall effect.

The turbidity of the medium is determined by the amount of scattered light.

The transmitted infrared light beam is “scattered” by the particles present in the medium.

The “scattered” light beams are detected and processed by photo-receivers placed at an angle of 90° with respect to the directrix of the transmitted light beam.

The signals due to the “scattered” light are then converted into frequency signals' which are assigned to corresponding turbidity values and are thus shown on the display.

Principle of 90° light scattering

$$I_s = I_0 \cdot A \cdot C \cdot f(\alpha)$$

Where:

I_0 = Intensity of the transmitted light

I_s = Intensity of the scattered light

A = Geometric factor

C = Molar concentration

$f(\alpha)$ = Angular correlation

P = Particle

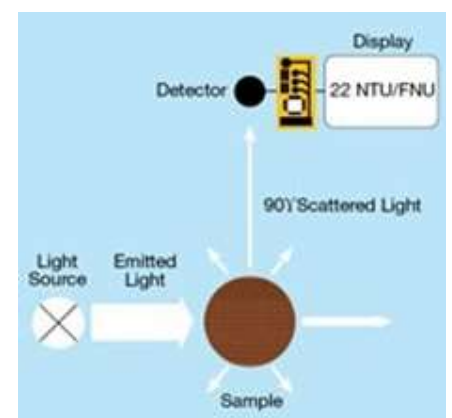

12.2 - CHARACTERISTICS AND DIMENSIONS

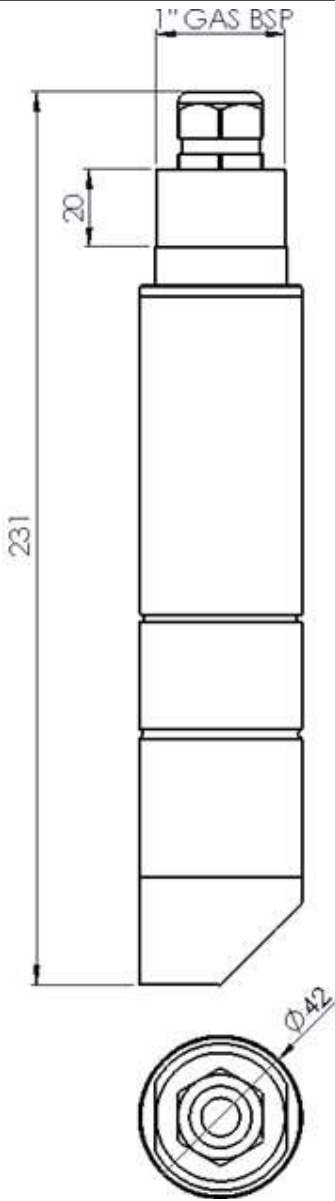
TECHNICAL	DIMENSIONS
Materials: - Body in black PVC and AISI 316 - Special Glass Optics - Silicone and NBR OR	
Threading: 1" GAS	
Measuring ranges: 0-1000 NTU, 0-4000 NTU	
Measuring method: 90° scattering	
Resolution: - 0.01 NTU range 0-1000 NTU - 0.01 NTU range 0-4000 NTU	
Precision: - ±2% sul punto di misura range 0-1000 NTU - ±5% sul punto di misura range 0-4000 NTU	
Repeatability: - ±5 NTU range 0-1000 NTU - ±20 NTU range 0-4000 NTU	
Calibration: 1 point	
Operating temperature: 0÷50°C, 0÷75°C if in AISI 316	
Maximum operating pressure: 4 bar	
Mechanical protection: IP68 Sensor+cable	
Cable: 10m connected to the sensor (other on request)	
Power supply: 12...24Vdc	
Max Absorption: 3W	
Outputs: RS485 (4-20mA optional)	

12.2.1 - PROBE CALIBRATION

Single point:

This calibration mode is used to change the offset of the entire line and must only be performed when the turbidity value of the point we are calibrating is above 1 NTU, because the probe does not allow changing of the offset if the turbidity values are too low.

Circulate water with a known solution, making sure that there are no air bubbles in the circuit: to eliminate them, a slight back pressure can be created by partially closing the outlet flow. The liquid can also stay still inside the probe-holder, but be careful of deposit phenomena that could distort the reading. Wait approximately 4-5 minutes for the value to stabilise and proceed with the calibration by entering the value of the known solution from the keyboard.

From the RUN menu of the instrument, press the left arrow to access the configuration menus; then scroll with the up or down arrow keys to select SET PROBE and press the right arrow then select "CH 164CH UIDx" and press the right arrow, and finally select "CALIBRATION" and press the right arrow to access the 164CH sensor calibration procedure.

12.2.1.1 - CALIBRATION

Select CALIBRATION and confirm with the "RIGHT" key.

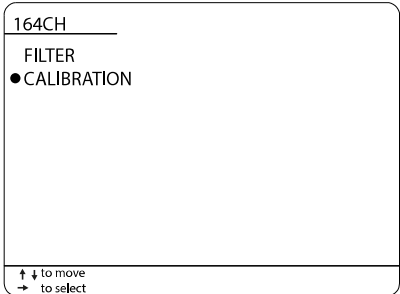

12.2.1.1.1 - 1 POINT CALIB

Select 1 POINT CALIB and confirm with the "RIGHT" key.

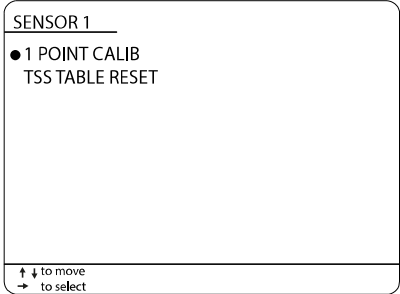

Enter the turbidity value of the sample solution. With "RIGHT" move the cursor and with "UP" modify the digit. Confirm with "ENTER".

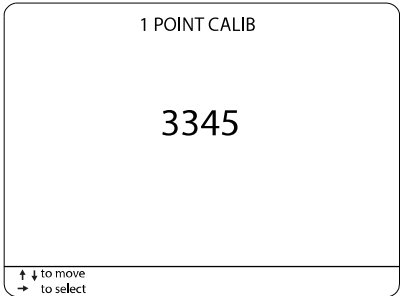

12.2.1.1.2 - TSS TABLE RESET 1 POINT

Select TSS TABLE RESET and confirm with the "RIGHT" key.

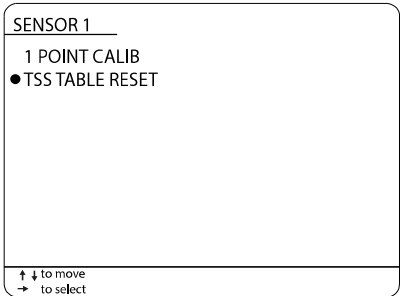

Select YES to reset the TSS table and restore the factory calibrations. Select with the "UP" or "DOWN" keys. Confirm the selection with the "RIGHT" key

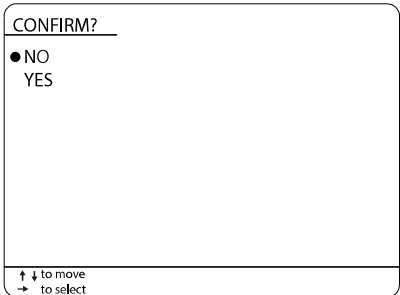

12.2.2 - BYPASS INSTALLATION (FOR PVC VERSIONS)

Install the probe inside the beaker. To facilitate correct insertion, a warning label is placed on the probe body indicating the direction of flow.

When the probe is installed, the calibration curve must be modified to compensate for the offset of the probe holder wall.

ATTENTION!!! each bypass probe holder has its own intrinsic structure which could slightly interfere with the reading, so each probe + probe-holder system must be calibrated together.

It is advisable to install an outlet tap to reduce the flow and thus create inside the probe holder a pressure that is able to promote the elimination of any air bubbles.

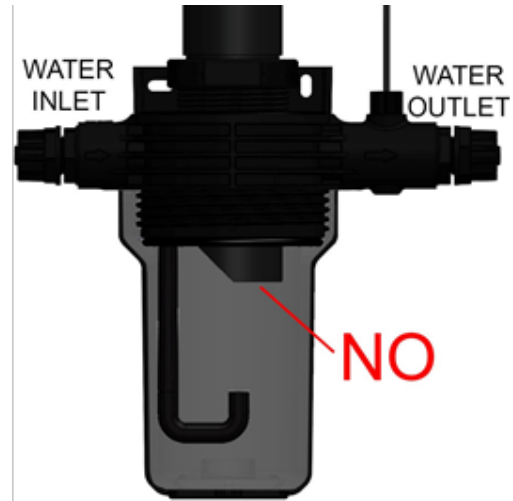
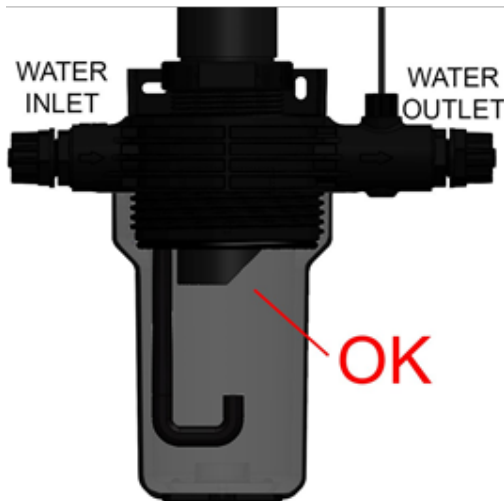

12.2.3 - INSTALLATION IN TANK OR CISTERN

Install the probe inside the tank so that it is immersed by at least 20 cm and so that the distance from the walls and bottom of the tank itself is not less than 20 cm.

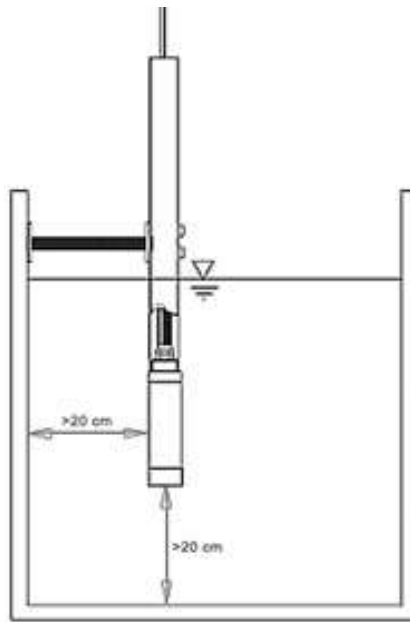

12.2.4 - CHANNEL INSTALLATION

Also in this case, install the probe inside the channel so that it is immersed by at least 20 cm and so that the distance from the walls and the bottom of the tank itself is not less than 20 cm.

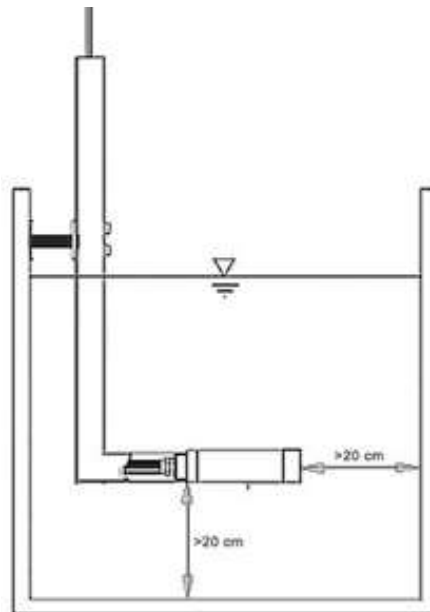

12.2.5 - ANCHOR DEVICES ON THE TANK

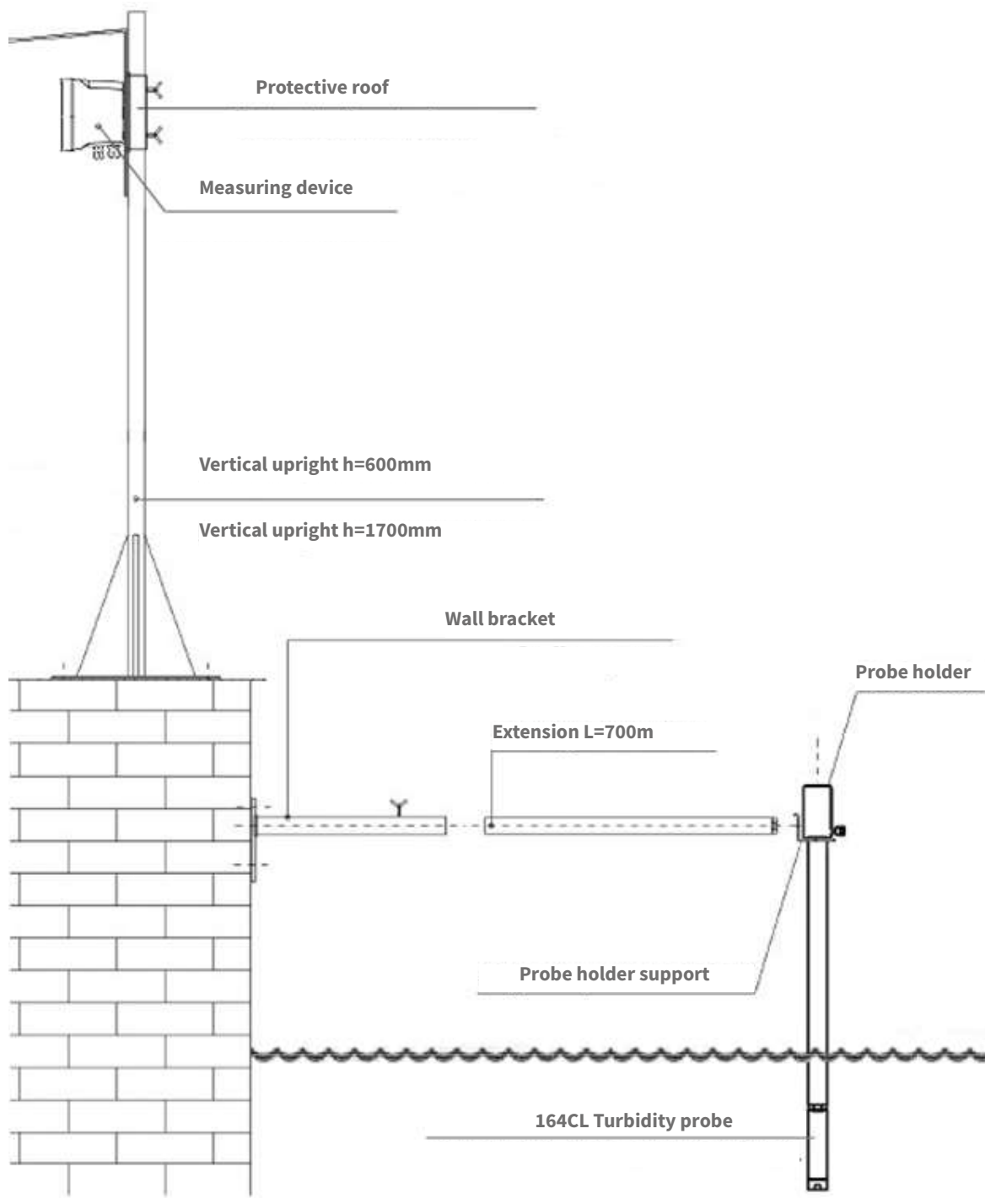

12.2.6 - DEVICE FOR INSERTION IN PIPING

Name of the parts included in the supply:

1. Valve block
2. Probe block
3. Stop Pole (2)
4. M12 Nut (4)
5. Washer 12 (8)
6. O-ring 4050 (8)
7. Weld-on SS316 stub pipe
8. Bolt M16x60 (2)
9. Nut M16 (2)

Instructions for correct assembly:

Unscrew the stub pipe (7) from the valve block (1) and weld it on the pipe.

Unscrew the two M16x60 bolts (8) from the respective nuts (9).

Unscrew the two upper M12 nuts (4) from the stop poles (3) and remove the upper washers (5) and o-rings (6).

Then insert the probe block (2) inside the valve block (1) until the two flanges of the respective blocks and the corresponding holes are aligned.

Pass the stop poles (3) through the holes in the probe block and then reinsert the upper washers (5) and o-rings (6) and screw the upper M12 bolts (4) back into the stop poles (3).

Repeat this latter procedure with the M16x60 bolts (8) and tighten.

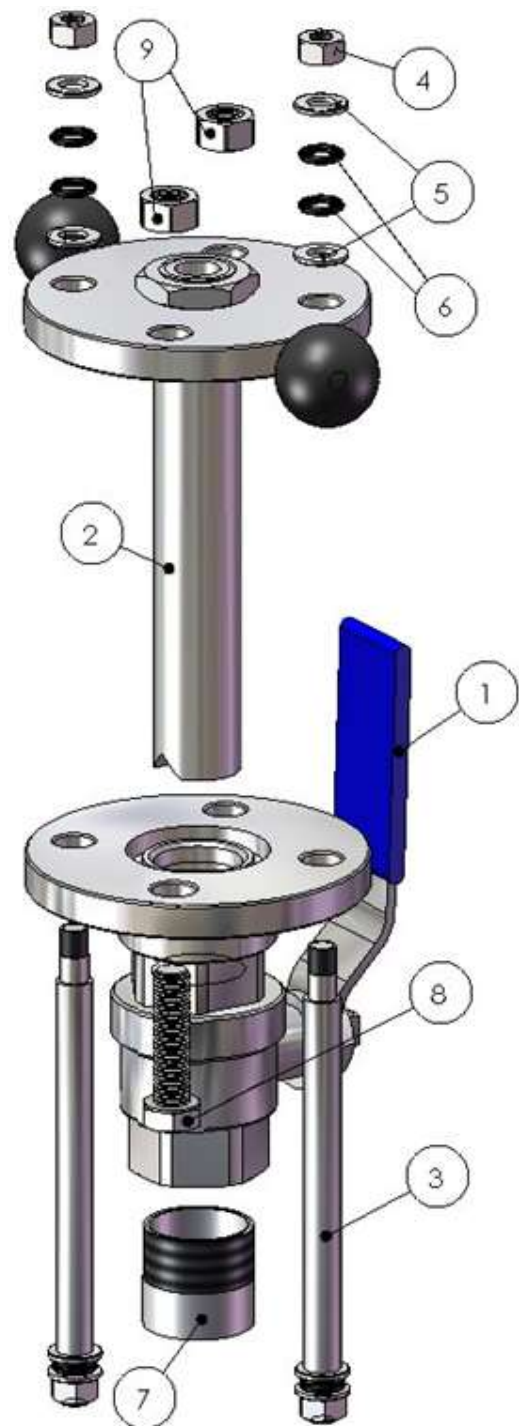

12.2.7 - PIPING INSTALLATION PRECAUTIONS

Model probe 164CH

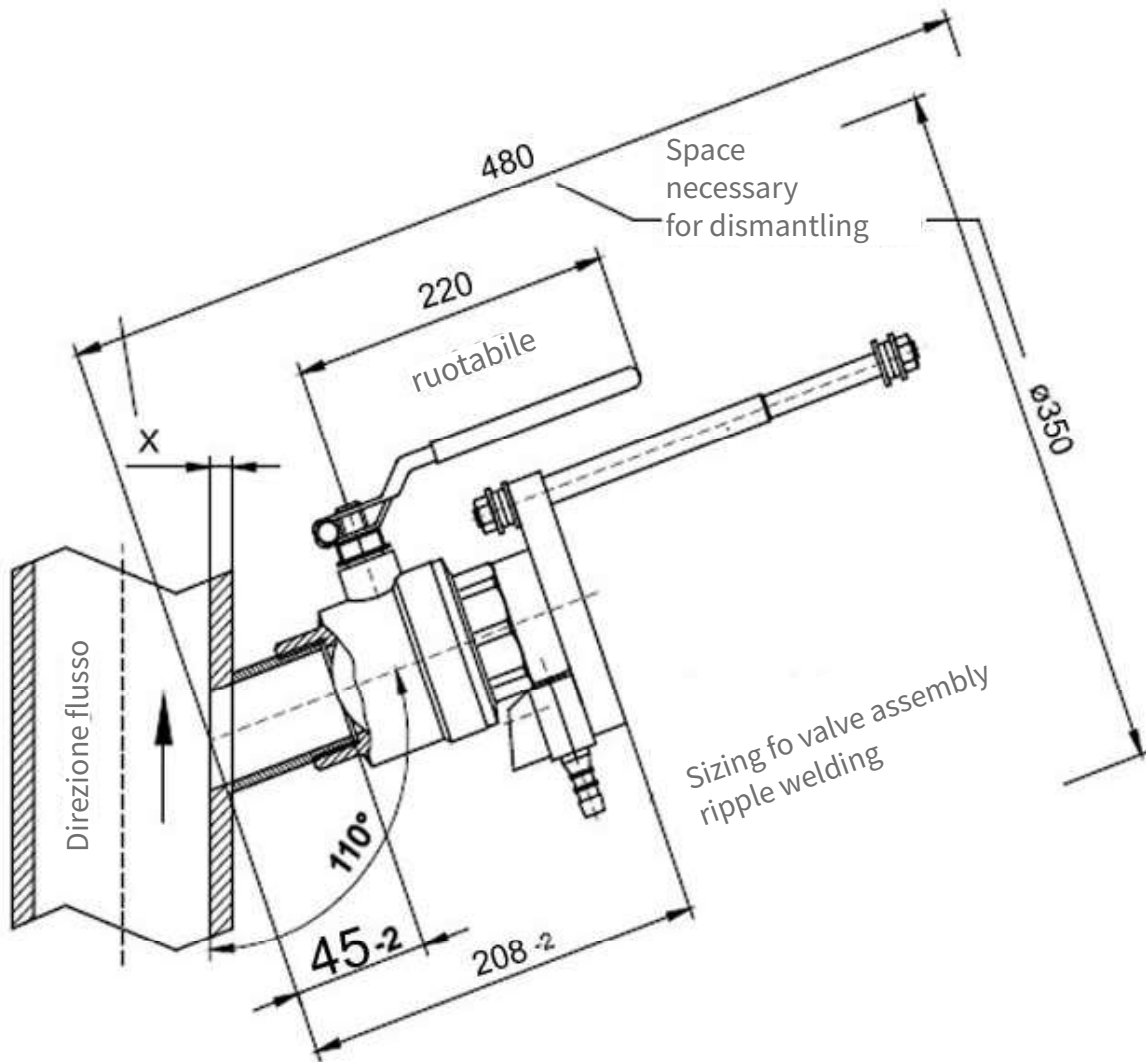

Attention: the measurements refer to the inner wall of the pipe

Attention: orient the probe so that the glasses are in the direction opposite to the flow.

12.3 - CONFIGURATION

Access the configuration menu by pressing the “LEFT” key.

Select PROBE SET-UP with “UP” or “DOWN and confirm with the“ RIGHT ”key.

N.B. – The composition of the PROBE SET-UP menu depends on the sensors connected to the MCA800. For example, if only probes 324C with UID 2 and 164CH with UID 1 were connected to the MCA800, the menu would only consist of the lines “S: CH 324C UID2” and “S: CH 164CH UID1”. The figure to the side shows a menu where the 164CH sensor is preconfigured with the UID1 address.

12.3.1 - 164CH – INFRARED HIGH TURBIDITY

Select S : CH 164CH UIDx and confirm with the “RIGHT” key.

12.3.1.1 - FILTER

Select FILTER and confirm with the “RIGHT” key.

Enter the filter value. Dividing the set value by 2230 gives the equivalent in seconds; e.g.: 3345/2230=1.5s. With “RIGHT” move the cursor and with “UP” modify the digit. Confirm with “ENTER.

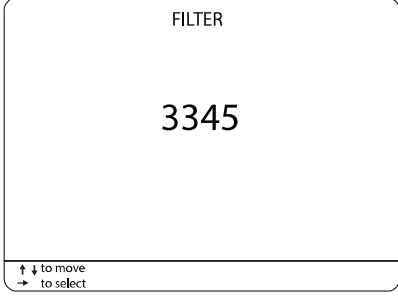
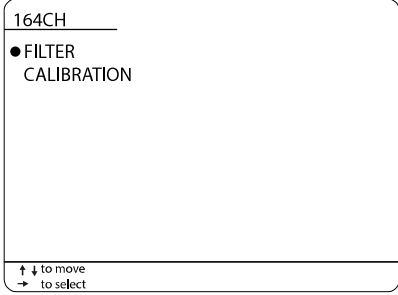
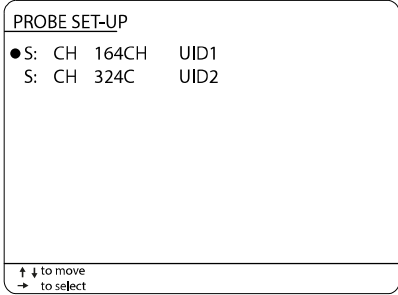
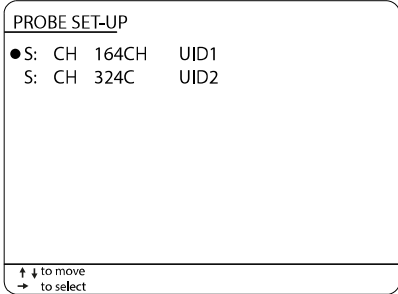
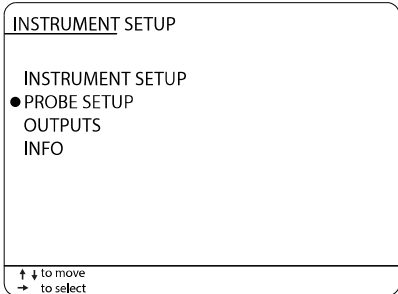

12.3.1.2 - CALIBRATION

Select CALIBRATION and confirm with the “RIGHT” key.

164CH
FILTER
● CALIBRATION

↑ ↓ to move
→ to select

12.3.1.2.1 - CALIB 1 POINT

Select 1 POINT CALIB and confirm with the “RIGHT” key.

SENSOR 1
● 1 POINT CALIB
TSS TABLE RESET

↑ ↓ to move
→ to select

Enter the turbidity value of the sample solution.
With “RIGHT” move the cursor and with “UP” modify the digit.
Confirm with “ENTER.”

1 POINT CALIB

3345

↑ ↓ to move
→ to select

13-INFRARED SUSPENDED SOLIDS MEASUREMENT

13.1 164CU - Infrared suspended solids

The 164CU sensor is used for the optical measurement of the solid suspended in process water up to 30 g/l. It uses the infrared (880nm) pulsed light method according to Lambert Beer's law.

13.1.1 - APPLICATIONS

- Measurement of suspended solids in wastewaters.
- Measurement of sludge concentration in industrial waters.

12.1.2 - CHARACTERISTICS AND ADVANTAGES

- Reliable concentration measurement by optical measuring process.
- Diffusion method of pulsating beams of infrared light.
- Sensor body made of stainless steel.
- No mechanical moving parts.
- Pre-processing of the measured value in the sensor resulting in low signal transmission sensitivity.

13.2 - CHARACTERISTICS AND DIMENSIONS

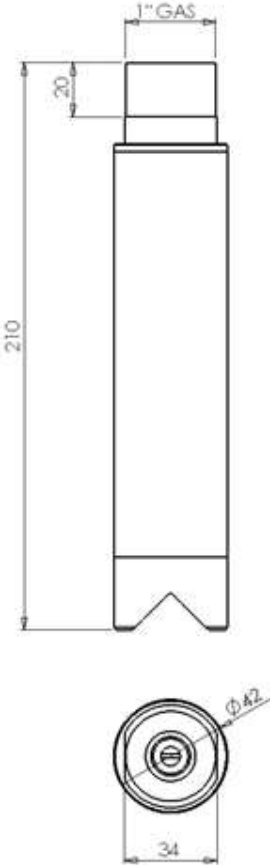
TECHNICAL	DIMENSIONS
Materials: - Body made of stainless steel 1.4401 (316) - Special epoxy windows - O-ring in Viton	
Threading: 1" GAS	
Measuring range: 0÷30g/l	
Measuring method: light absorption at 880nm	
Precision: ± 3% of f.s.	
Repeatability: 98%	
Operating temperature: 0÷60 °C	
Maximum operating pressure: 4 bar	
Mechanical protection: IP68 Including cable	
Cable: 10m (other on request)	
Power supply voltage: 12...24Vdc	
Digital output: RS485	

13.2.1 - TANK INSTALLATION

Install the probe in the tank so that it is immersed by at least 20 cm and the distance from the walls and bottom of the tank is not less than 20 cm.

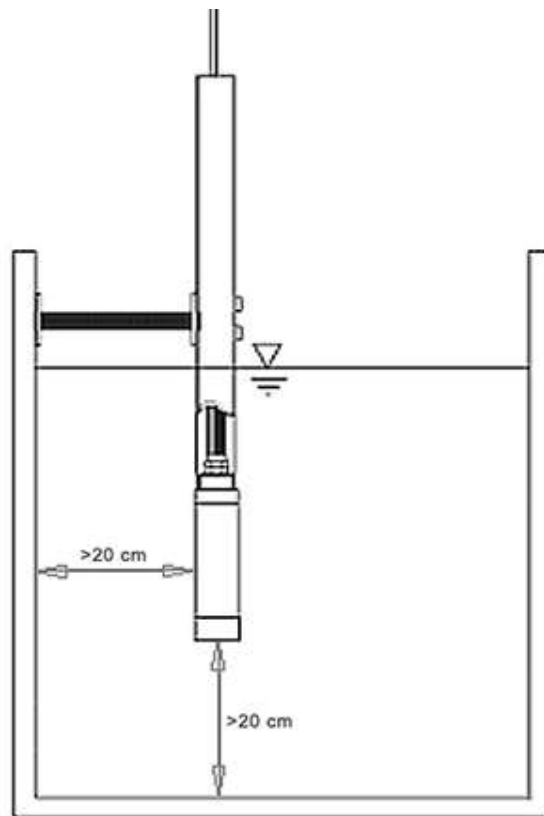

13.3 - CONFIGURATION

Access the configuration menu by pressing the “LEFT” key.

Select PROBE SET-UP with “UP” or “DOWN and confirm with the“ RIGHT ”key.

N.B. – The composition of the PROBE SETUP menu depends on the sensors connected to the MCA800.

For example, if only probes 164CU with UID 1 and 324C with UID 2 were connected to the MCA800, the menu would only consist of the lines “S: CH 164CU 4C UID1” and “S: CH 324C UID2”.

The figure to the side shows a menu where the 164CU sensor is preconfigured with the UID1 address

13.3.1 - 164CU – INFRARED SUSPENDED SOLIDS MEASUREMENT

Select S : CH 164CU UIDx and confirm with the “RIGHT” key.

13.3.1.1 - FILTER

Select FILTER and confirm with the “RIGHT” key.

Enter the filter value.

With “RIGHT” move the cursor and with “UP” modify the digit.

Confirm with “ENTER.

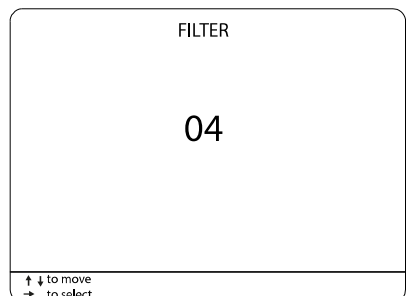
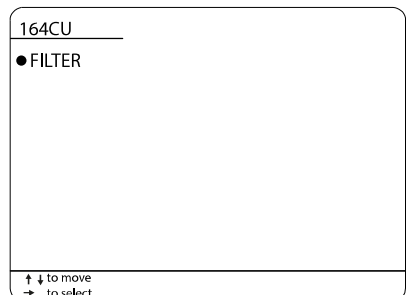
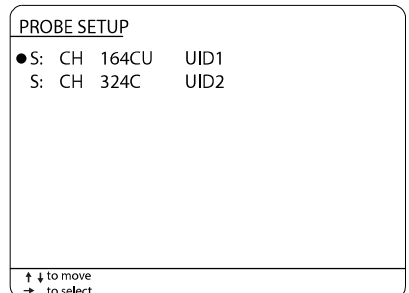
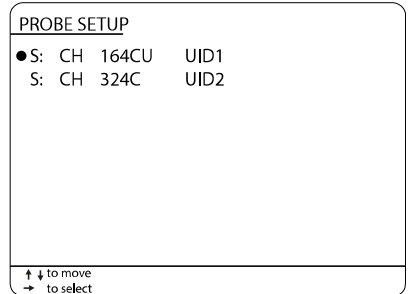
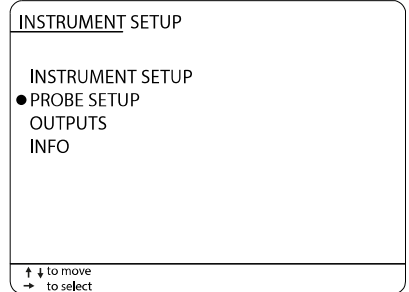

14-MISURA REDOX (ORP) CON SENSORE TEMP. INTEGRATO

14.1 - 604C - Redox Measurement (orp) with built-in temp. sensor

The 604C sensor is used for the differential measurement of ORP in pure waters, waste water treatment systems, in processes with encrusting suspended solids, in processes with pollutants, in processes with high concentrations of sulphides, in coagulation and flocculation processes, in scrubbers, in galvanic processes, for surface finishes, in processes for the elimination or recovery of heavy metals.

14.1.1 - APPLICATIONS

- Purifiers and treatment of waste waters.
- Coagulation and flocculation.
- Process monitoring and control.
- Acid/caustic effluent neutralisation system.

14.1.2 - CHARACTERISTICS AND ADVANTAGES

- Reliable ORP measurement thanks to the use of a digital measuring process.
- Measurement communication via MODBUS RTU protocol.
- The ability to perform all calibrations via serial.
- Absence of mechanical moving parts.
- Immediate installation and easy maintenance.

14.1.3 - OPERATING PRINCIPLE

The 604C electrode is suitable for Redox (ORP) measurements in various applications.

The porous septum in liquid Teflon® is resistant to encrustations and chemical attack.

The double reference electrode increases the service life in applications containing sulphides (H₂S) and metals such as lead, mercury and silver.

The new cast-in-place reference electrolyte helps maintain a constant reference cell potential, resisting dilution over time with changes in pressure and temperature.

The new capillary temperature sensor design places the Pt100 sensor behind the Redox Sensitive Membrane (ORP) for very precise temperature measurement and compensation.

The IP68 environmental protection protects the high impedance signal of the Redox (ORP) electrode from moisture deriving from condensation that has accumulated in the immersed pipes.

14.2 - CHARACTERISTICS AND DIMENSIONS

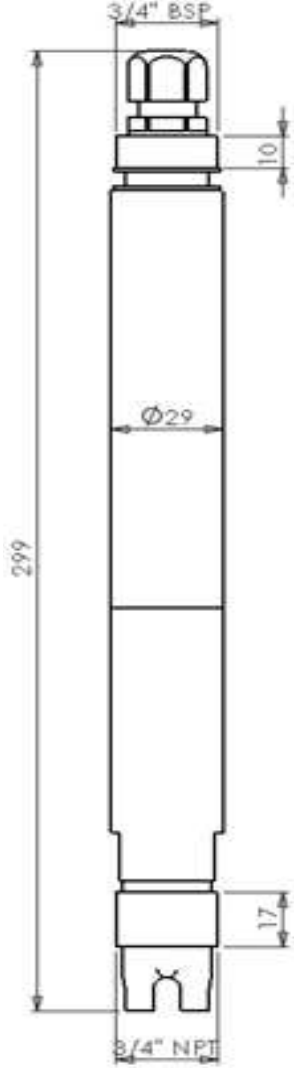
TECHNICAL SPECIFICATIONS	DIMENSIONS
Materials: - Body in Ryton® and PVC - O-Rings in Viton® - Other materials Teflon®, carbon, epoxy	
Measuring electrode: Hemispherical glass membrane	
Threading: 3/4" NPT, 3/4" BSP	
Measuring ranges: -1500mV ÷ +1500mV	
Calibration method: calibration on 1 point with certified standard Redox solutions	
Measuring method: Digital	
Resolution: ±1 mV	
Precision: ±5 mV	
Repeatability: ±3 mV	
Response time: T90<60s	
Temperature Probe: PT100	
Immersion operating temperature: 0÷50°C (122°F)	
Piping operating temperature: 0÷80°C	
Maximum operating pressure: 11 bar	
Minimum operating conductivity: 50µS	
Maximum absorption: 2W	
Mechanical protection: IP68 Sensor+cable	
Cable: 10m connected to the sensor (others on request)	
Power supply: 12...24Vdc	
Communication: RS485 Modbus	
Equipotential contact for solution: included	
Dimensions (LxHxP): 29x299x29mm	

14.3 - CONFIGURATION

Access the configuration menu by pressing the "LEFT" key.

Select PROBE SET-UP with "UP" or "DOWN" and confirm with the "RIGHT" key.

N.B. – The composition of the PROBE SET-UP menu depends on the sensors connected to the MCA800.

For example, if only probes 604C with UID 1 and 324C with UID 2 were connected to the MCA800, the menu would only consist of the lines "S: CH 604C UID1" and "S: CH 324C UID2".

The figure to the side shows a menu where the 604C sensor is preconfigured with the UID1 address.

INSTRUMENT SETUP

```

INSTRUMENT SETUP
● PROBE SETUP
  OUTPUTS
  INFO
  
```

↑ ↓ to move
→ to select

PROBE SET-UP

```

● S: CH 604C   UID1
  S: CH 324C   UID2
  
```

↑ ↓ to move
→ to select

14.3.1 - FILTER

Select FILTER and confirm with the “RIGHT” key.

604C
<ul style="list-style-type: none"> ● FILTER CALIBRATION RESET CALIB
↑ ↓ to move → to select

Enter the filter value. R.
 With “RIGHT” move the cursor and with “UP” modify the digit.
 Confirm with “ENTER”.

FILTER
03
↑ ↓ to move → to select

14.3.2 - CALIBRATION

Select CALIBRATION and confirm with the “RIGHT” key.

604C
<ul style="list-style-type: none"> FILTER ● CALIBRATION RESET CALIB
↑ ↓ to move → to select

Enter the known Redox value.
 With “RIGHT” move the cursor and with “UP” modify the digit.
 Confirm with “ENTER”.

CALIBRATION
0000
↑ ↓ to move → to select

14.3.2 - RESETCALIB

Select RESET CALIB

604C
<ul style="list-style-type: none"> FILTER CALIBRATION ● RESET CALIB
↑ ↓ to move → to select

Select YES to restore the factory calibrations.
 Select with the “UP” or “DOWN” keys.
 Confirm the selection with the “RIGHT” key

CONFIRM?
<ul style="list-style-type: none"> ● NO YES
↑ ↓ to move → to select

15-MCA800 CONFIGURATION

15.1 - INSTRUMENT SET-UP

Access the configuration menu by pressing the “LEFT” key.

Select INSTRUMENT SETUP and confirm with the “RIGHT” key.

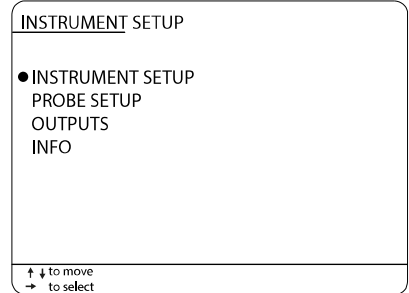

15.1.1 - LANGUAGE

Select LANGUAGE and confirm with the “RIGHT” key.

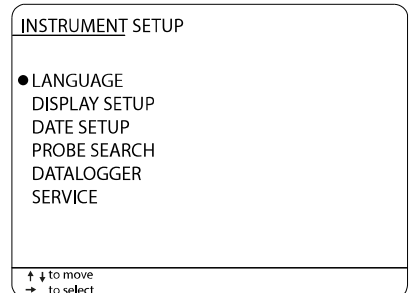

Select the language of the menus.
Range: ENGLISH; ITALIANO
Select with the “UP” or “DOWN” keys.

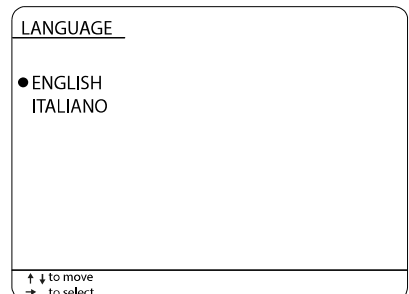

15.1.2 - DISPLAY SET-UP

Select DISPLAY SET-UP and confirm with the “RIGHT” key.

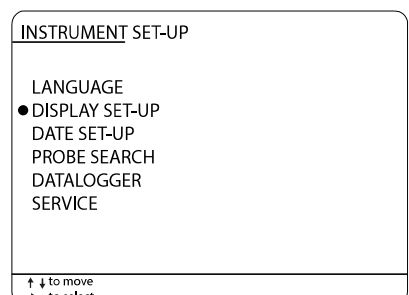

15.1.2.1 - DISPLAY COLOUR

Select DISPLAY COLOUR and confirm with the “RIGHT” key.

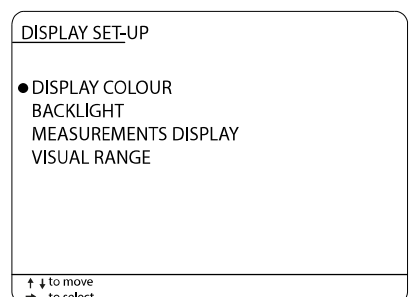

Select the colour of the background and of the wording.
Range: WHITE on BLUE (white wording on a blue field);
WHITE on BLACK (white wording on a black field);
YELLOW on BLACK (yellow wording on a black field);
Select with the “UP” or “DOWN” keys.
Confirm the selection with the “RIGHT” key.

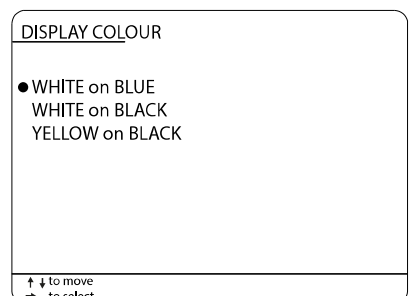

15.1.2.2 - BACKLIGHT

Select BACKLIGHT and confirm with the “RIGHT” key.

DISPLAY SET-UP
DISPLAY COLOUR <input checked="" type="radio"/> BACKLIGHT MEASUREMENTS DISPLAY VISUAL RANGE
↑ ↓ to move → to select

BACKLIGHT
00
↑ ↓ to move → to select

15.1.2.3 - MEASUREMENTS DISPLAY

Select MEASUREMENTS DISPLAY and confirm with the “RIGHT”.

DISPLAY SET-UP
DISPLAY COLOUR BACKLIGHT <input checked="" type="radio"/> MEASUREMENTS DISPLAY VISUAL RANGE
↑ ↓ to move → to select

MEASUREMENTS DISPLAY
<input checked="" type="radio"/> ROTATION ALL TOGETHER
↑ ↓ to move → to select

Select the measurements display mode:

ROTATION, one measurement per page will be displayed in large fonts.

ALL TOGETHER, the measurements will be displayed simultaneously on a single page.

Select with the “UP” or “DOWN” keys.

Confirm the selection with the “RIGHT” key.

15.1.2.4 - VISUAL RANGE

Select VISUAL RANGE and confirm with the “RIGHT” key.

DISPLAY SET-UP
DISPLAY COLOUR BACKLIGHT MEASUREMENTS DISPLAY <input checked="" type="radio"/> VISUAL RANGE
↑ ↓ to move → to select

VISUAL RANGE
00
↑ ↓ to move → to select

Enter the value in seconds of the time in which the backlight remains active after the last pressing of a key.

With a value of 00, the backlight does not turn off. Range: 0÷99s

With “RIGHT” move the cursor and with “UP” modify the digit.

Confirm with “ENTER”.

15.1.3 - DATE SET-UP

Select DATE SET-UP and confirm with the “RIGHT” key.

INSTRUMENT SET-UP
LANGUAGE DISPLAY SET-UP ● DATE SET-UP PROBE SEARCH DATALOGGER SERVICE
↑ ↓ to move → to select

15.1.3.1 - YEAR/MONTH/DAY/HOURS/MINUTES

Select YEAR/MONTH/DAY/HOURS/MINUTES and confirm with the “RIGHT” key.

DATE SET-UP
● YEAR MONTH DAY HOURS MINUTES
14/09/2020 15:04:38
↑ ↓ to move → to select

Enter the year/month/day/hours/minutes.

With “RIGHT” move the cursor and with “UP” modify the digit.
Confirm with “ENTER”.

YEAR/MONTH/DAY/HOURS/MINUTES
00
↑ ↓ to move → to select

15.1.4 - PROBE SEARCH

Select PROBE SEARCH and confirm with the “RIGHT” key.

INSTRUMENT SET-UP
LANGUAGE DISPLAY SET-UP DATE SET-UP ● PROBE SEARCH DATALOGGER SERVICE
↑ ↓ to move → to select

MCA800 automatically searches for the connected sensors.

PROBE 1 FOUND SEARCHING FOR PROBE 2

↑ ↓ to move → to select

MCA800 displays the number of sensors found, their UID address and the sensor model

PROBES FOND 1
UID 1: CH 604C
↑ ↓ to move → to select

15.1.5 - DATALOGGER

Select DATALOGGER and confirm with the “RIGHT” key.

INSTRUMENT SET-UP
LANGUAGE DISPLAY SET-UP DATE SET-UP PROBE SEARCH ● DATALOGGER SERVICE
↑ ↓ to move → to select

15.1.5.1 - DATALOGGER RANGE

Select “DATALOG RANGE” with the “DOWN” key and confirm the choice with the “RIGHT” key.

DATALOGGER
● DATALOGGER RANGE CONNECT USB DISCONNECT USB
↑ ↓ to move → to select

Enter the range time, in seconds, for data storage
 (min.10 sec., max. 3600 sec.).
 To move the cursor, use “RIGHT” and “UP” to modify the digit.
 To confirm “ENTER”.

DATALOGGER RANGE
0020sec
↑ ↓ to move → to select

15.1.5.2 - CONNECT USB

Only if the Pen Drive is inserted into the USB port after switching on the MCA800, select “CONNECT USB” and confirm with the “RIGHT” key.

DATALOGGER
DATALOGGER RANGE
● CONNECT USB
DISCONNECT USB
↑ ↓ to move → to select

Wait for the system to recognise the Pen Drive connected to the MCA800 USB port.

WAIT ...
↑ ↓ to move → to select

Pen Drive connected to the system. The message is displayed “USB CONNECTED” and the data logger is enabled to write data to the file.

USB CONNECTED
↑ ↓ to move → to select

Failed to connect. The “USB NOT CONNECTED” message appears.

Check:

- insertion into the USB port.
- that the formatting mode (File System) of the Pen Drive is “FAT32” (formatting).

USB NOT CONNECTED
↑ ↓ to move → to select

15.1.5.3 - DISCONNECT USB

Before removing the Pen Drive to read the file, select “DISCONNECT USB” with the “DOWN” key and confirm the choice with the “RIGHT” key.

DATALOGGER
DATALOGGER RANGE
CONNECT USB
● DISCONNECT USB
↑ ↓ to move → to select

Wait for the system to disconnect the Pen Drive connected to the MCA800 USB port.

WAIT ...
↑ ↓ to move → to select

The message “REMOVE USB DEVICE” appears.
Now it is possible to remove the Pen Drive.

REMOVE USB DEVICE

↑ ↓ to move
→ to select

15.1.6 - SERVICE

Select SERVICE and confirm with the “RIGHT” key.

INSTRUMENT SET-UP

LANGUAGE
DISPLAY SET-UP
DATE SET-UP
PROBE SEARCH
DATALOGGER
● SERVICE

↑ ↓ to move
→ to select

15.1.6.1 - RESTORE

Select RESTORE and confirm with the “RIGHT” key.

SERVICE

● RESTORE
UID SET-UP

↑ ↓ to move
→ to select

Select YES to restore the instrument’s factory settings.
Range: YES; NO
Select with the “UP” or “DOWN” keys.
Confirm the selection with the “RIGHT” key.

RESTORE

● NO
YES

↑ ↓ to move
→ to select

15.1.6.2 - UID SET-UP

Select “UID SET-UP” with the “DOWN” key and confirm the choice with the “RIGHT” key:

SERVICE

RESTORE
● UID SET-UP

Enter the UID address assigned to the slave port of the MCA800 in the MODBUS RTU network.
to move the cursor “RIGHT” and “UP” to modify the digit.
To confirm “ENTER”.

Set MY UID

01

↑ ↓ to move
→ to select

15.2 - OUTPUTS

Access the configuration menu by pressing the “LEFT” key.

Select OUTPUTS and confirm with the “RIGHT” key.

INSTRUMENT SET-UP
INSTRUMENT SET-UP PROBE SET-UP ● OUTPUTS INFO
↑ ↓ to move → to select

15.1.1 - RELAY 1/2/3/4/5

Select RELAY1/2/3/4/5 and confirm with the “RIGHT” key.

OUTPUTS
● RELAY 1 RELAY 2 RELAY 3 RELAY 4 RELAY 5 DIGITAL 1 DIGITAL 2 ANALOGICAL1 ANALOGICAL2
↑ ↓ to move → to select

15.1.2 - THRESHOLD

Select THRESHOLD and confirm with the “RIGHT” key.

RELAY1/2/3/4/5
● THRESHOLD NONE
↑ ↓ per spostarsi → per selezionare

15.1.2.1 - PROBE

Press “RIGHT” to select “PROBE”.

INSTRUMENT SET-UP
● PROBE MODE THRESHOLD VALUE THRESHOLD HYSTERESIS SAFETY DELAY
↑ ↓ to move → to select

Select the probe linked to the relay threshold, or NONE for no probe, and confirm the selection with the “RIGHT” key.

RELAY1
S:CH S461 TM UID1 ● S:CH 324C UID2 NONE
↑ ↓ to move → to select

15.1.2.2 - MODE

Press “RIGHT” to select “MODE”.

Select “min” for minimum level alarm or “MAX” for maximum level alarm.
Confirm the selection with the “RIGHT” key.

INSTRUMENT SET-UP
PROBE <input checked="" type="radio"/> MODE THRESHOLD VALUE THRESHOLD HYSTERESIS SAFETY DELAY
↑ ↓ to move → to select

RELAY1
<input checked="" type="radio"/> min <input type="radio"/> MAX
↑ ↓ to move → to select

15.1.2.3 - THRESHOLD VALUE

To set the relay intervention point, select
“THRESHOLD VALUE” and confirm the selection with the “RIGHT”.

Set the threshold value. Use “RIGHT” to move the cursor and “UP”
to modify the digit.
Confirm with “ENTER”.

INSTRUMENT SET-UP
PROBE MODE <input checked="" type="radio"/> THRESHOLD VALUE THRESHOLD HYSTERESIS SAFETY DELAY
↑ ↓ to move → to select

VALUE SET-UP
00000.00
↑ ↓ to move → to select

15.1.2.4 - THRESHOLD HYSTERESIS

To set the relay intervention point, select
“THRESHOLD HYSTERESIS” and confirm the selection with the “RIGHT” key.

Set the threshold hysteresis value. “RIGHT” to move the cursor and “UP”
to modify the digit.
Confirm with “ENTER”.

INSTRUMENT SET-UP
PROBE MODE THRESHOLD VALUE <input checked="" type="radio"/> THRESHOLD HYSTERESIS SAFETY DELAY
↑ ↓ to move → to select

VALUE SET-UP
00000.00
↑ ↓ to move → to select

15.1.2.5 - SAFETY

To set the relay status during the alarm condition, select “SAFETY” and confirm with the “RIGHT” key.

Select:

“YES” relay de-energised in alarm condition; “NO” relay energised in alarm condition. Confirm with the “RIGHT” key.

15.1.2.6 - DELAY

To set the relay intervention point, select “DELAY” and confirm the selection with the “RIGHT” key.

Set the threshold hysteresis value. ”RIGHT” to move the cursor and “UP” to modify the digit. Confirm with “ENTER”.

15.1.2.7 - NONE

Select NONE to disable the relay function and confirm with the “RIGHT” key.

INSTRUMENT SET-UP
PROBE MODE THRESHOLD VALUE THRESHOLD HYSTERESIS ● SAFETY DELAY
↑ ↓ to move → to select

SAFETY
● NO YES
↑ ↓ to move → to select

INSTRUMENT SET-UP
PROBE MODE THRESHOLD VALUE THRESHOLD HYSTERESIS SAFETY ● DELAY
↑ ↓ to move → to select

VALU SET-UP
00 sec.
↑ ↓ to move → to select

RELAY1/2/3/4/5
● THRESHOLD NONE
↑ ↓ to move → to select

15.1.3 - DIGITAL 1/2

PENDING

OUTPUTS
RELAY 1
RELAY 2
RELAY 3
RELAY 4
RELAY 5
● DIGITAL 1
DIGITAL 2
ANALOGICAL1
ANALOGICAL2

↑ ↓ to move
→ to select

15.1.4 - ANALOGICAL 1/2

Select ANALOGICAL1/2 and confirm with the “RIGHT” key.

OUTPUTS
RELAY 1
RELAY 2
RELAY 3
RELAY 4
RELAY 5
DIGITAL 1
DIGITAL 2
● ANALOGICAL1
ANALOGICAL2

↑ ↓ to move
→ to select

15.1.4.1 - SENSOR 1/2

Select SENSOR 1/2 to match the analogical output channel to the sensor and confirm with the “RIGHT” key.

ANALOGICAL 1/2
● SENSOR 1
SENSOR 2
NONE

↑ ↓ to move
→ to select

Select the analogical output mode: 4÷20mA to set 4mA at 0 and 20mA at full scale of the sensor; 20÷4mA to set the 20mA at 0 and 4mA at the full scale of the sensor.

The start and full scale values of the measurement range depend on the sensor range connected, for example: if the sensor connected is the 164CU for suspended solids, the 4mA will correspond to the measurement of 0mg/l, while the 20mA will correspond to the measurement of 30mg/l.

Select with the “UP” or “DOWN” keys.

Confirm the selection with the “RIGHT” key.

SENSOR 1/2/3/4
● 4÷20mA
20÷4mA

↑ ↓ to move
→ to select

15.2 - INFO

Select INFO and confirm with the “RIGHT” key.

INSTRUMENT SET-UP
INSTRUMENT SET-UP
PROBE SET-UP
OUTPUTS
● INFO

↑ ↓ to move
→ to select

The system information is shown:

- FW_rev; indicates the firmware revision.
- ICx.x.xx; indicates the hardware configuration index.
- Last restore; indicates the date on which the last system restore was.

Fw_rev 0.00
IC1.2.04
Last restore 10/09/2020

A series of horizontal dashed lines spaced evenly down the page, providing a template for handwritten notes.

16-TESTING / QUALITY CERTIFICATE



In accordance with production and testing procedures, it is hereby certified that:

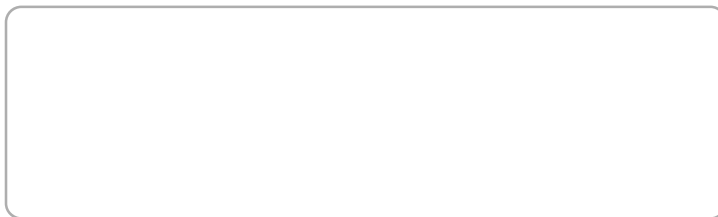

(Chemical analysis unit)

satisfies the technical characteristics mentioned in the TECHNICAL DATA paragraph and complies with the construction procedures

Quality control manager: Date of manufacture and testing:



This mark on the instrument indicates that the product and its electronic accessories must not be disposed of with other household waste at the end of their useful life. To avoid possible damage to the environment or to human health resulting from uncontrolled waste disposal, please deliver the appliance directly to a company specialising in recycling, in compliance with the local regulations.



NI - MH

This instrument is powered by a 2.4V AAA, 0.6Ah NiMH rechargeable battery pack; at the end of the battery or instrument's life, do not dispose of in the environment. The battery must be disposed of at the appropriate collection centres.