

# RPmagM

electromagnetic flowmeter MID certified

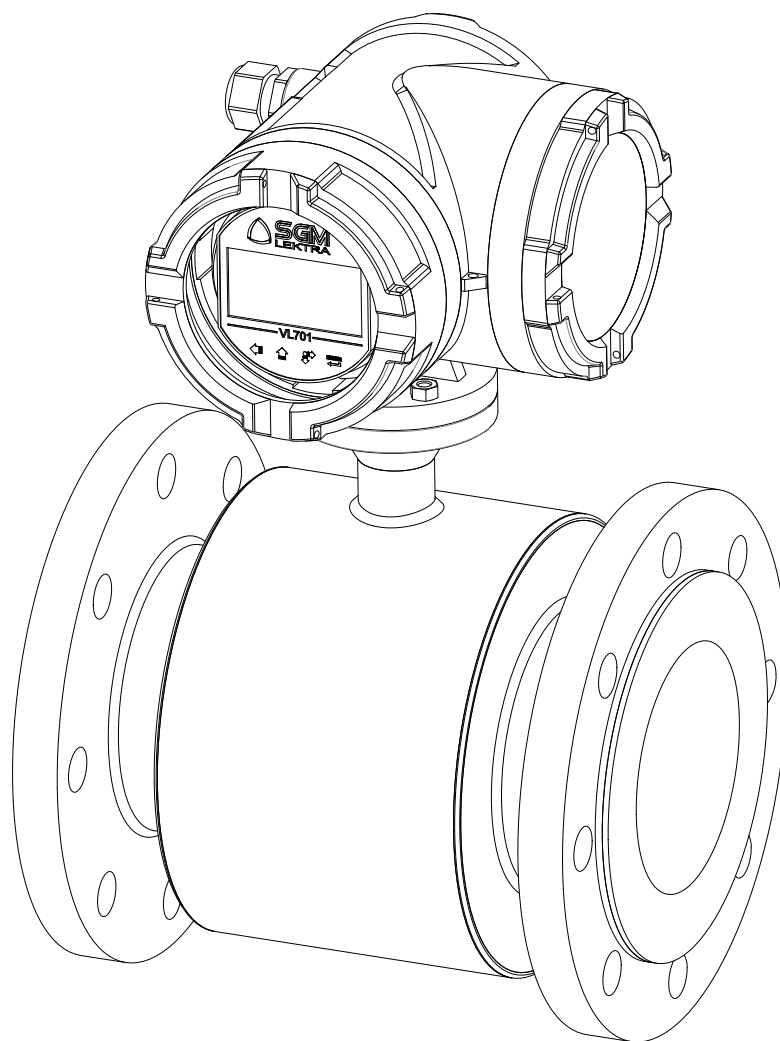

technical documentation EN Rev. of 22/03/2023

# CONTENTS

---

<b>1-WARRANTY</b>	page 3
<b>2-MID CERTIFICATE</b>	page 3
<b>3-PRODUCT</b>	page 4
<b>4-PERFORMANCE SPECIFICATIONS</b>	page 5
<b>5-FLOW RANGE</b>	page 6
<b>6-DIMENSIONS</b>	page 7
<b>7-INSTALLATION</b>	page 11
<b>8-ELECTRICAL CONNECTIONS</b>	page 19
<b>9-LOCAL OPERATOR INTERFACE (LOI)</b>	page 26
<b>10-PROGRAMMING</b>	page 30
<b>11-FACTORY TEST AND QUALITY CERTIFICATE</b>	page 56

# 1-WARRANTY

Products supplied by SGM LEKTRA are guaranteed for a period of 12 (twelve) months from delivery date according to the conditions specified in our sale conditions document.

SGM LEKTRA can choose to repair or replace the Product.



If the Product is repaired it will maintain the original warranty terms, whereas if the Product is replaced it will have 12 (twelve) months of warranty.

The warranty will be null if the Client modifies, repair or uses the Products for other purposes than the normal conditions foreseen by instructions or Contract.

In no circumstances shall SGM LEKTRA be liable for direct, indirect or consequential or other loss or damage whether caused by negligence on the part of the company or its employees or otherwise howsoever arising out of defective goods

# 2-MID CERTIFICATE

You can download the entire document from our website.

 <b>Slovenský metrologický ústav</b> Karloveská 63, 842 55 Bratislava 4, Slovenská republika	
<b>CERTIFIKÁT EÚ SKÚŠKY TYPU</b> <i>EU – type examination certificate</i>	
Číslo dokumentu: <i>Document number:</i>	<b>SK 17-MI001-SMU051</b> <span style="float: right;"><b>Revízia 0</b> <i>Revision 0</i></span>
V súlade s: <i>In accordance with:</i>	nariadením vlády Slovenskej republiky č. 145/2016 Z. z. o sprístupňovaní meradiel na trhu, ktorým sa preberá smernica Európskeho parlamentu a Rady 2014/32/EU o harmonizácii právnych predpisov členských štátov týkajúcej sa sprístupnenia meradiel na trhu <i>Government Ordinance of the Slovak Republic No. 145/2016 Coll. relating to the making available on the market of measuring instruments, which implemented the Directive 2014/32/EU of the European Parliament and of the Council on the harmonisation of the laws of the Member States relating to the making available on the market of measuring instruments</i>
Žiadateľ/Výrobca: <i>Issued to (Manufacturer):</i>	<b>SGM Lektra s.r.l.</b> <b>Via Papa Giovanni 23°, n.49, 20090 Rodano (MI), ITALY</b>
Druh meradla: <i>Type of instrument:</i>	<b>Vodomer (MI-001)</b> <i>Water meter (MI-001)</i>
Označenie typu: <i>Type designation:</i>	<b>RPMAG</b>
Základné požiadavky: <i>Essential requirements:</i>	príloha č. 1 a príloha č. 3 Vodometry (MI-001) k nariadeniu vlády SR č. 145/2016 Z. z. <i>Annex No. I and Annex No. III Water meters (MI-001) to Government Ordinance of SR No. 145/2016 Coll.</i>
Platnosť do: <i>Valid until:</i>	<b>11. júna 2027</b> <i>June 11, 2027</i>
Notifikovaná osoba: <i>Notified body:</i>	<b>Slovenský metrologický ústav 1781</b> <i>Slovak Institute of Metrology 1781</i>
Dátum vydania: <i>Date of issue:</i>	<b>12. júna 2017</b> <i>June 12, 2017</i>
Základné charakteristiky, popis meradla a podmienky schválenia sú uvedené v prílohe, ktorá je súčasťou tohto certifikátu. Certifikát vrátane prílohy má spolu 12 strán. <i>Essential characteristics, instrument description and approval conditions are set out in the appendix hereto, which forms the part of the certificate. The certificate including the appendix contains 12 pages.</i>	
	
 <b>Emanuel Godál</b> zástupca notifikovanej osoby <i>representative of notified body</i>	
Poznámka: Tento certifikát EÚ skúšky typu môže byť rozmnožovaný len celý a nezmenený. Bez podpisu a odtlačku pečiatky je neplatný. <i>Note: This EU-type examination certificate shall not be reproduced except in full. Certificates without signature and stamp are not valid.</i>	

## 3- PRODUCT

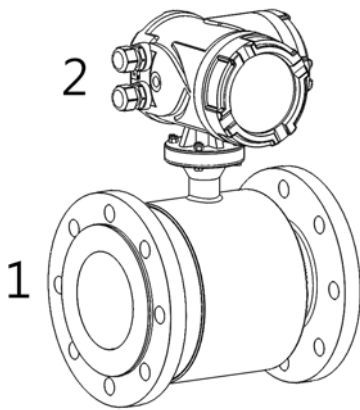

### COMPACT VERSION

1. Sensor
2. Converter

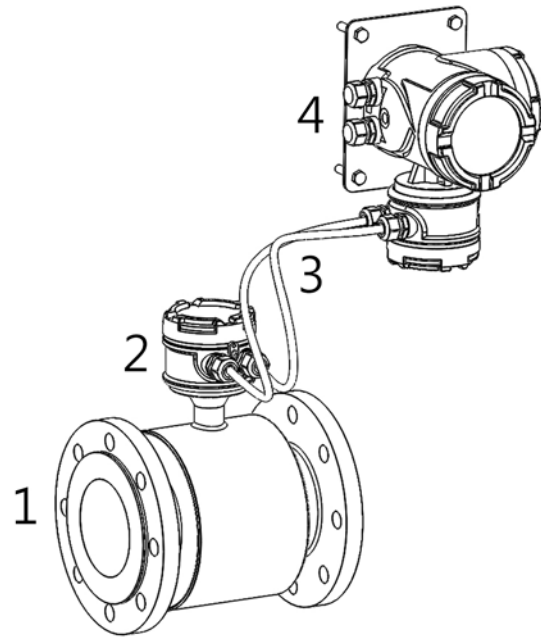





### REMOTE VERSION

1. Sensor
2. Connection housing
3. Connection cables
4. Converter, wall mouting

### 3.1 IDENTIFICATION

Each meter has an adhesive identification plate on which are the meter main data.  
The following picture describes the information and data on the identification plate.

		  	
Via Papa Giovanni XXIII, 49 20090 Rodano (MI) - ITALY			
<b>Model:</b>	<b>RPMAG_</b>	<b>Cert. No:</b>	<b>SK17-MI001-SMU051</b>
<b>S.N.:</b>	_____	<b>Year:</b>	<b>2017</b>
<b>Meter n°:</b>	<b>xxxxxx</b>	<b>M.U.:</b>	<b>m³/h</b>
<b>P.Supply:</b>	<b>85÷265Vac 50÷60Hz</b>	<b>Q3: xxx; Q3/Q1:</b>	<b>200</b>
<b>Connection:</b>	<b>DNxx PNxx; IP67</b>	<b>MAP.16; Δp10; T50</b>	
<b>Lining:</b>	<b>RUBBER</b>	<b>Flow Profile:</b>	<b>U5 D3</b>
<b>Electrode:</b>	<b>SS316</b>	<b>T. amb.:</b>	<b>5°C÷40°C</b>
<b>Sens. Factor:</b>	<b>0.2293</b>	<b>Environ. class:</b>	<b>E1, M1</b>

## 4-FEATURES

---

### Flow rate range

RPmag is able to process signals from fluids with flow rates of up to 787,5m<sup>3</sup>/h in both directions (bidirectional meter).

### Range dimension / lining material

PTFE DN10 ÷ DN250 / RUBBER DN65 ÷ DN250

### Sensor material

SS321

### Housing material

epoxy painting aluminium

### Electrodes material

SS316L - Hastelloy C - Titanium - Tantalum - Platinum

### Accuracy

CLASS II

### Repeatability

±0,1%

### Fluid conductivity

>5µS/cm. / >20µS/cm. with demineralized water

### Power supply

85÷265Vac, 20÷30Vdc/Vac, 12Vdc

### Consumption

6W, max. 8W.

### TEMPERATURE CLASS

T50

### Sensor Pipe Temperature Limits

Remote version operating temperature: RUBBER -10 ÷ +80°C; PTFE -40 ÷ +150°C

Compact version operating temperature: RUBBER -10 ÷ +80°C; PTFE -40 ÷ +100°C

Storage temperature: -40÷85°C

### Converter temperature range

-20÷60°C

### Communication protocol

Modbus RTU

### Data Logger

Internal data logger to USB pen drive for event counter variations

### Output

4÷20mA: 0÷500Ω

Frequency output: 0,1÷10000 Hz

Pulse output: 24Vdc galvanically isolated or open collector or open collector galvanically isolated 24V 20mA (opt)

Alarm output: 2 relays, 3A 230Vac N.O.

### Reverse Flow

Allow measure reverse flow.

### Output Testing

Relays output: Transmitter can switch relays at testing value.

Current Source: Transmitter can be commanded to supply a specified test current between 4.0 and 20.0 mA.

Frequency Source: Transmitter can be commanded to supply a specified test frequency between 0 and 10000 Hz.

### Humidity Limits

0-100% RH to 150 °F (65 °C), not condensing.

### Damping

Adjustable between 1 and 99 seconds.

### Compact version IP rating

IP67

### Remote version IP rating

sensor IP67 / IP68 (by request) - converter IP67

### Anti-condensation filter

Anti-condensation filter installed on converter

## 5-FLOW RANGE

### 5.1 FLOW RANGE TABLES

DN10 ÷ 250	
DN (mm)	Range: Minimum / Maximum
10	0,0625 ÷ 2,5 m <sup>3</sup> /h
15	0,1575 ÷ 6,3 m <sup>3</sup> /h
20	0,25 ÷ 10 m <sup>3</sup> /h
25	0,4 ÷ 16 m <sup>3</sup> /h
32	0,625 ÷ 25 m <sup>3</sup> /h
40	1 ÷ 40 m <sup>3</sup> /h
50	1 ÷ 40 m <sup>3</sup> /h
65	1,575 ÷ 63 m <sup>3</sup> /h
80	4 ÷ 160 m <sup>3</sup> /h
100	6,25 ÷ 250 m <sup>3</sup> /h
125	6,25 ÷ 250 m <sup>3</sup> /h
150	10 ÷ 400 m <sup>3</sup> /h
200	15,75 ÷ 630 m <sup>3</sup> /h
250	15,75 ÷ 630 m <sup>3</sup> /h

### 5.2 LOAD LOSS

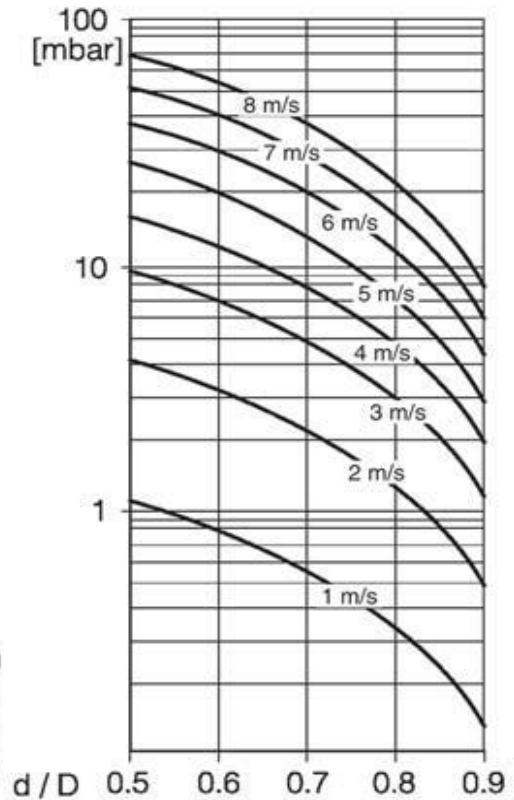
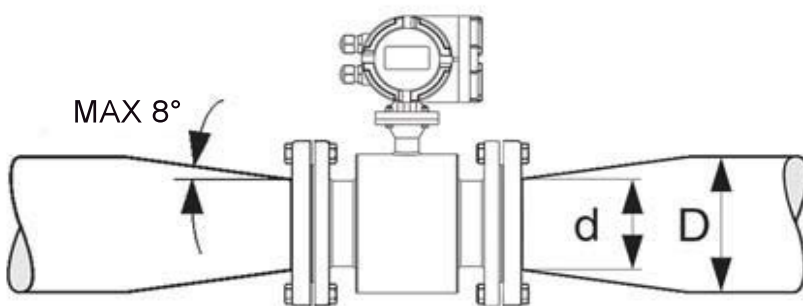

## 6-DIMENSIONS

### 6.1 REMOTE VERSION CONVERTER

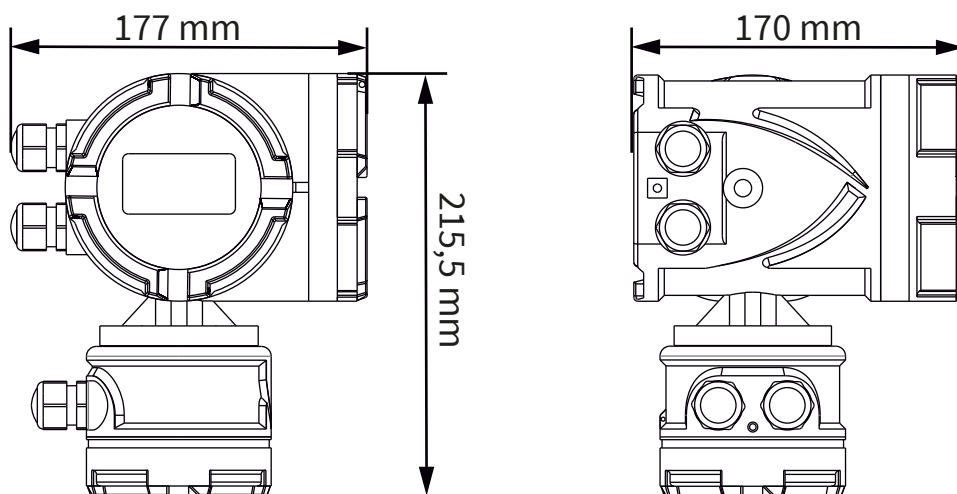

### 6.2 WALL MOUNTING REMOTE VERSION CONVERTER

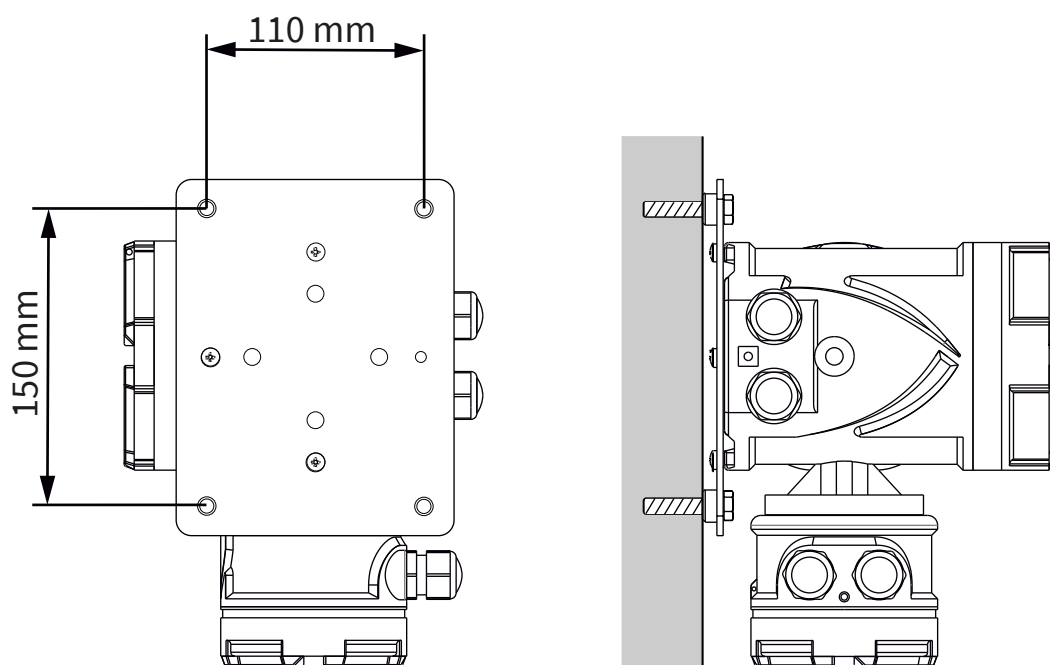

## 6.3 COMPACT VERSION DN10 ÷ DN80 PN16 - PN40

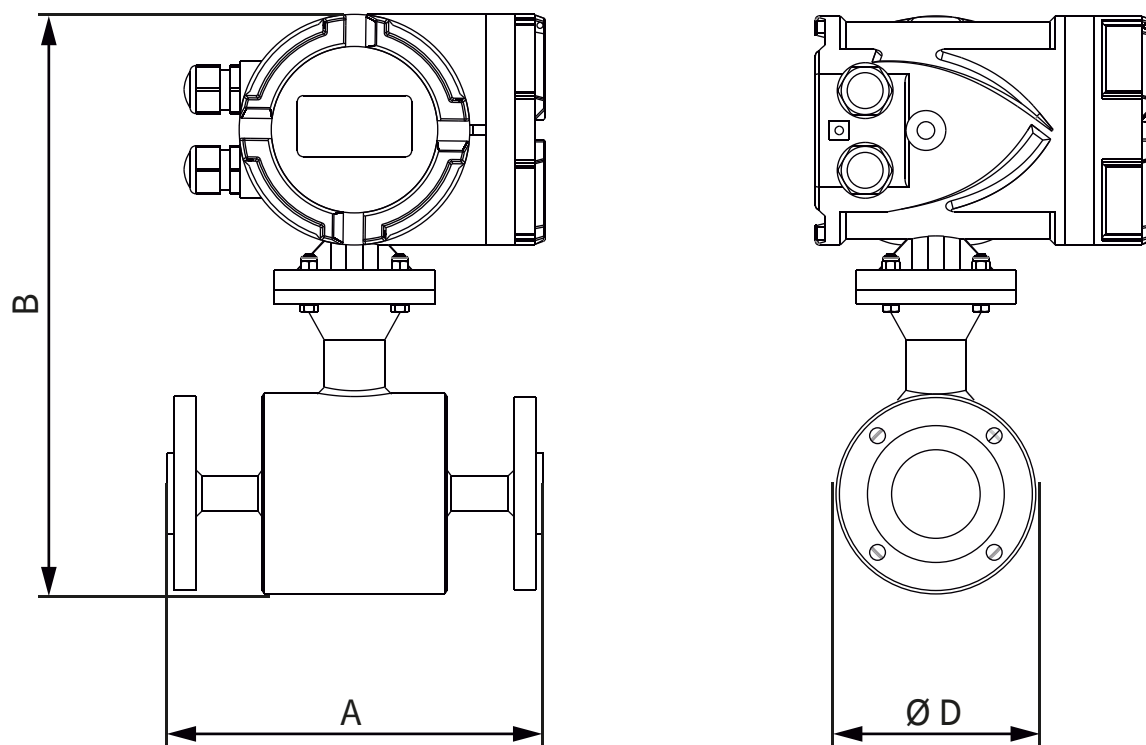

DN (mm)	A (mm)	PN 16 - PN 40	
		B (mm)	ØD (mm)
10	200	295	90
15		295	95
20		300	105
25		300	115
32		315	140
40		335	150
50		344	165
65		360	185
80		375	200



## 6.4 COMPACT VERSION DN100 ÷ DN250 PN10 - PN16 - PN40

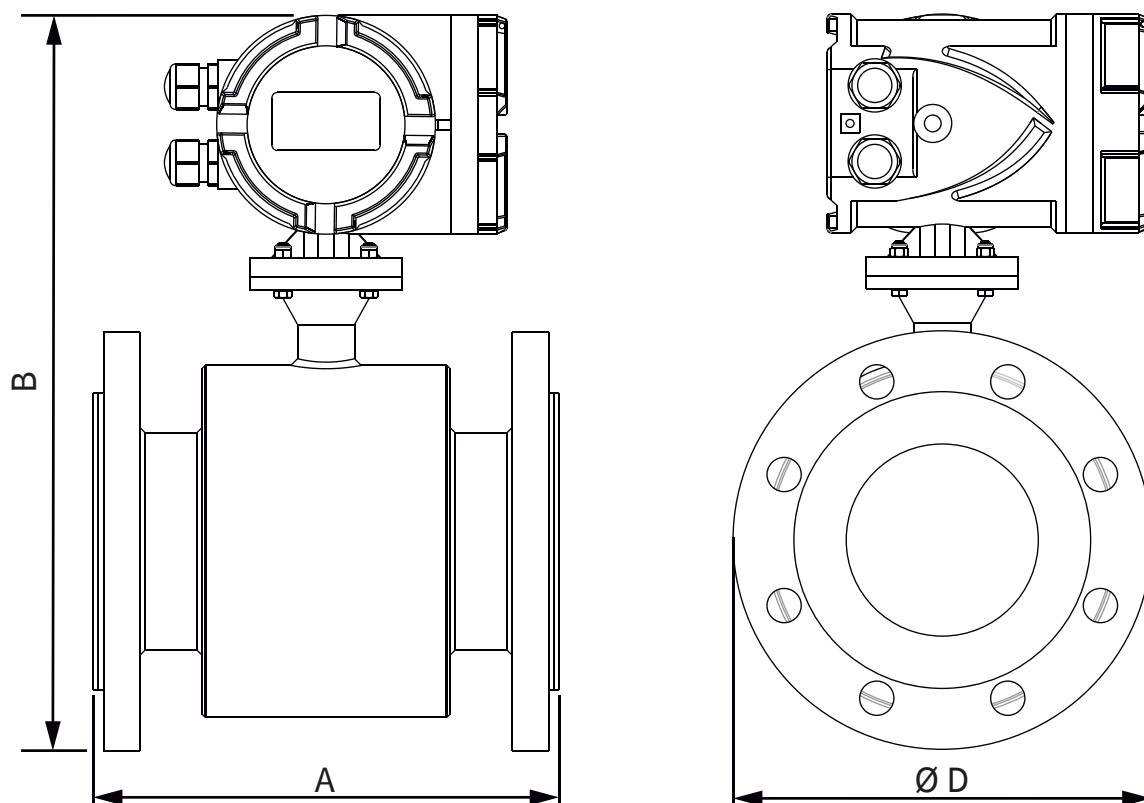

DN (mm)	A (mm)	PN 10		PN 16		PN 40	
		B (mm)	ØD (mm)	B (mm)	ØD (mm)	B (mm)	ØD (mm)
100	250	-	-	400	220	410	235
125	250	-	-	420	250	435	270
150	300	-	-	460	285	468	300
200	350	520	340	520	340	538	375
250	450	570	395	575	405	598	450

## 6.5 REMOTE VERSION DN10 ÷ DN25 PN16 - PN40

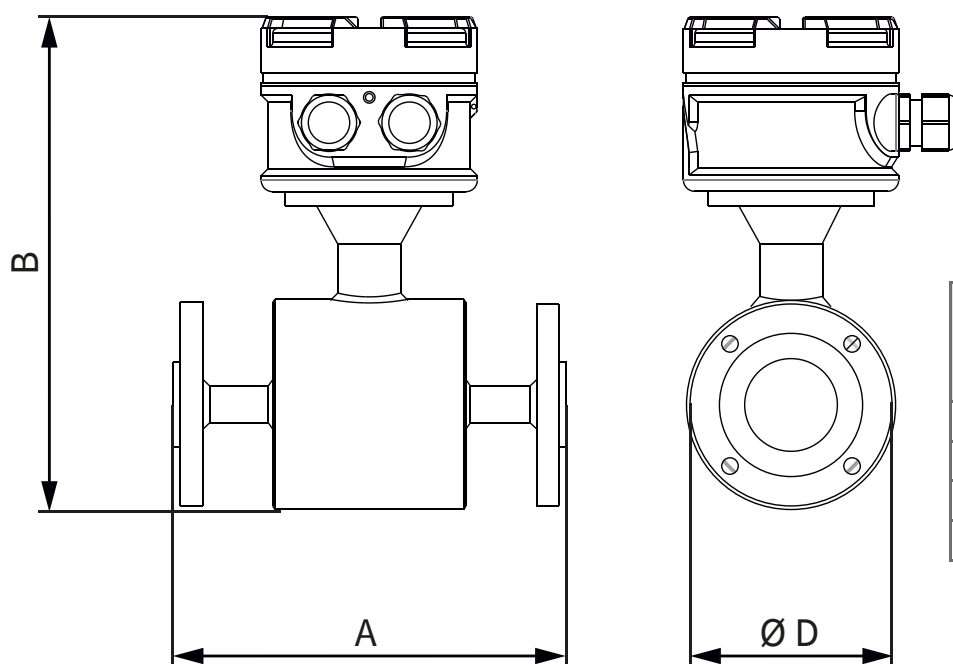

DN (mm)	A (mm)	PN 16 - PN 40	
		B (mm)	ØD (mm)
10	200	235	90
15		235	95
20		240	105
25		240	115

## 6.6 REMOTE VERSION DN32 ÷ DN1000 PN10 - PN16 - PN40

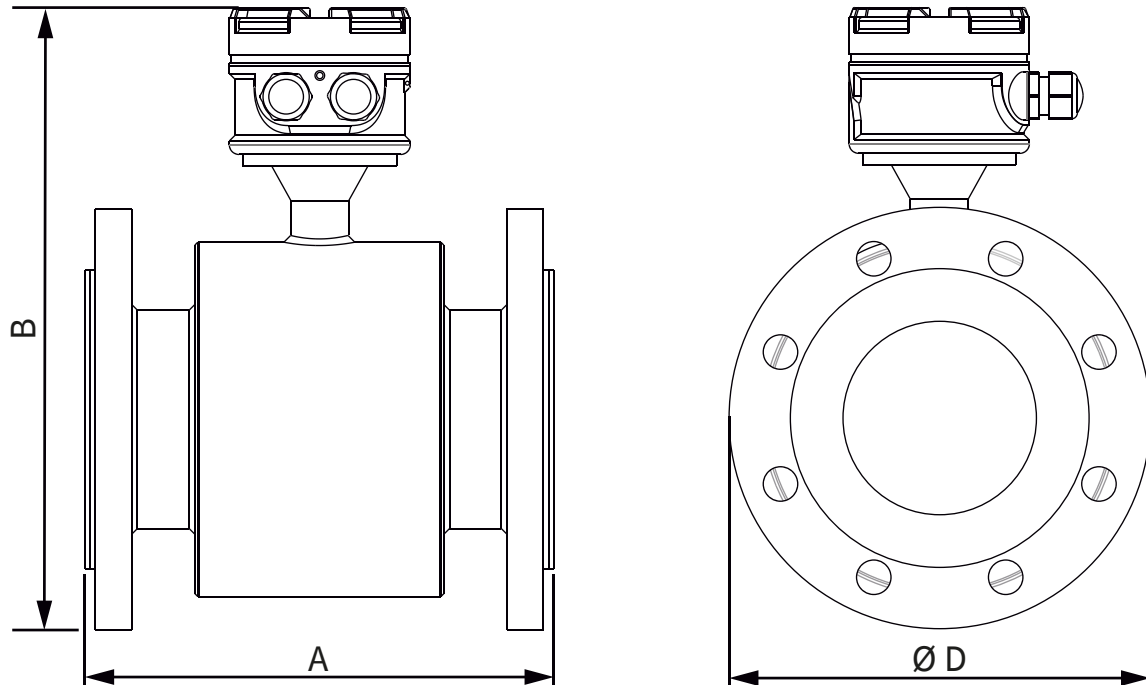

DN (mm)	A (mm)	PN 10		PN 16		PN 40	
		B (mm)	ØD (mm)	B (mm)	ØD (mm)	B (mm)	ØD (mm)
32	200	-	-	251	140	254	140
40	200	-	-	270	150	270	150
50	200	-	-	280	165	280	165
65	200	-	-	298	185	298	185
80	200	-	-	315	200	315	200
100	250	-	-	333	220	343	235
125	250	-	-	358	250	368	270
150	300	-	-	393	285	400	300
200	350	450	340	450	340	468	375
250	450	505	395	510	405	533	450

# 7-INSTALLATION

## 7.1 SAFETY MEASURE

Instructions and procedures in this section may require special precautions to ensure the safety of the personnel performing the operations. Information that raises potential safety issues are indicated by a warning symbol. Please refer to the following safety messages before performing an operation preceded by this symbol. ⚠

## 7.2 WARNINGS

### 7.2.1 Explosions could result in death or serious injury

- Verify that the operating atmosphere of the sensor pipe and transmitter is consistent with the appropriate hazardous locations certifications.
- Do not remove the transmitter cover in explosive atmospheres when the circuit is alive.

### 7.2.2 Failure to follow safe installation and servicing guidelines could result in death or serious injury

- Make sure only qualified personnel perform the installation.
- Do not perform any service other than those contained in this manual unless qualified.

### 7.2.3 High voltage that may be present on leads could cause electrical shock

- Avoid contact with leads and terminals.

## 7.3 PRE-INSTALLATION

There are several pre-installation steps that make the installation process easier.

They include identifying the options and configurations that apply to your application, setting the hardware switches if necessary, and consideration of mechanical, electrical, and environmental requirements.

Please remember that the sensor pipe liner is vulnerable to handling damage. Never place anything through the sensor pipe for the purpose of lifting or gaining leverage.

Damaged liner can render the sensor pipe useless.

### 7.3.1 Identify Options and Configurations

Standard application of the Rpmag includes control of the sensor pipe coils and one or more of the following configurations or options:

- 4÷20mA output
- Pulse output
- Alarm output
- Data logger

Be sure to identify the options and configurations that apply to your situation, and keep a list of them nearby during the installation and configuration procedures.

### 7.3.2 Mechanical Considerations

The mounting site for the Rpmag Transmitter should provide enough room for secure mounting, easy access to the conduit ports, full opening of the transmitter covers, and easy readability of the local operator interface (LOI) screen. The LOI can be rotated in 90° increments.

### 7.3.3 Lift

The flowmeter can be lifted using the lift as shown in following pictures.

The safe load and measure for the lift should reach to the relative requirement.

Don't lift the flowmeter using the rope to tie the connection between the sensor and the transmitter (compact version) or the connecting box (remote version)

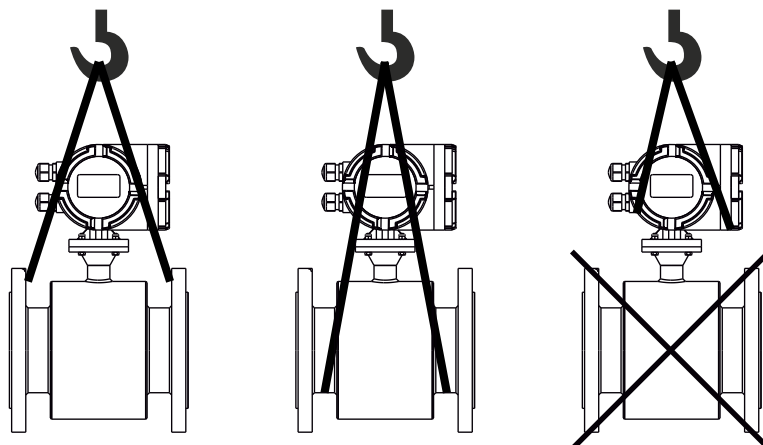

## 7.4 INSTALLATION GENERAL CRITERIA

The direction arrow marked on the nameplate is flow direction when calibrated in factory, you should install the flowmeter to make the actual flow direction same as the flow direction arrow marked on the nameplate.

If this is not possible, simply reverse the direct flow direction through the “Indication” (see par. 10.4.3.4.1).

The upstream straight pipe should be longer than 5XDN and the downstream straight pipe should be more than 3XDN in order to guarantee the accuracy of measurement.

## 7.5 INSTALLATION IN PIPELINE

Installation may be horizontal or vertical, but make sure no deposit on the electrodes or air bubbles when horizontal installation. See Fig.13-A.

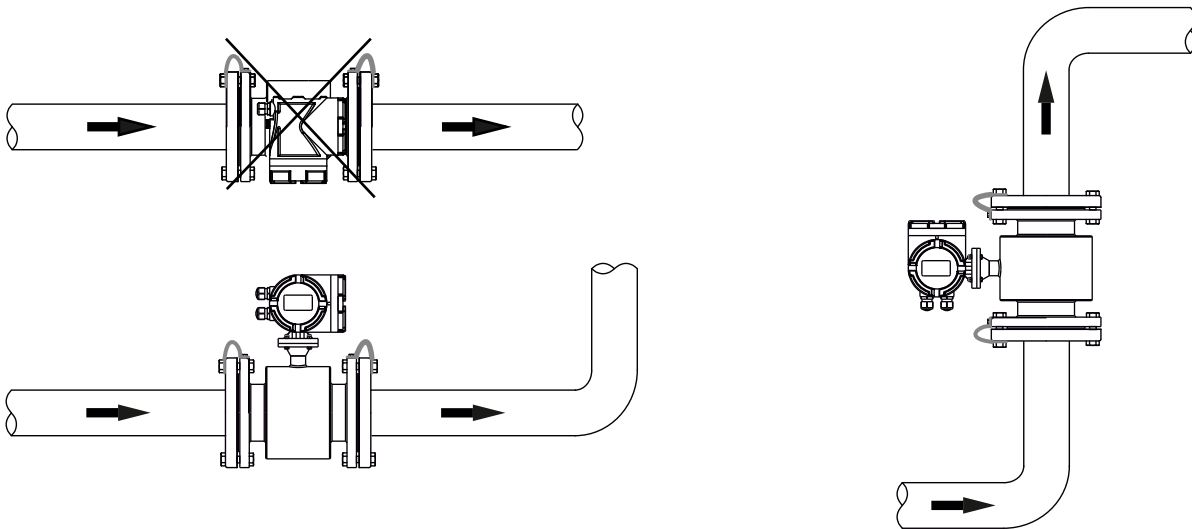

Fig.13-A. Installation in horizontal or vertical pipeline

To install a rectifier or straight pipe is necessary to normalize the flow profile if there are pipe elbows, flow regulation valves or half-open ball valves in front of the sensor. See fig.13-B.

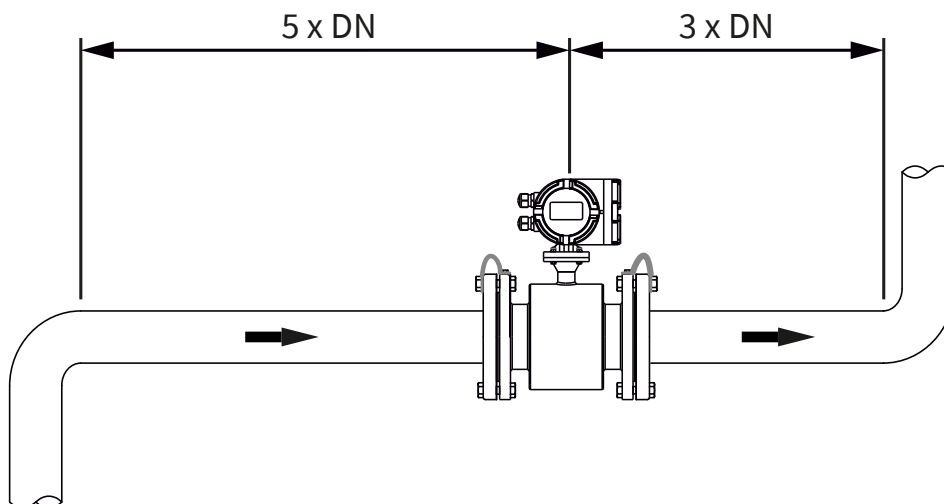
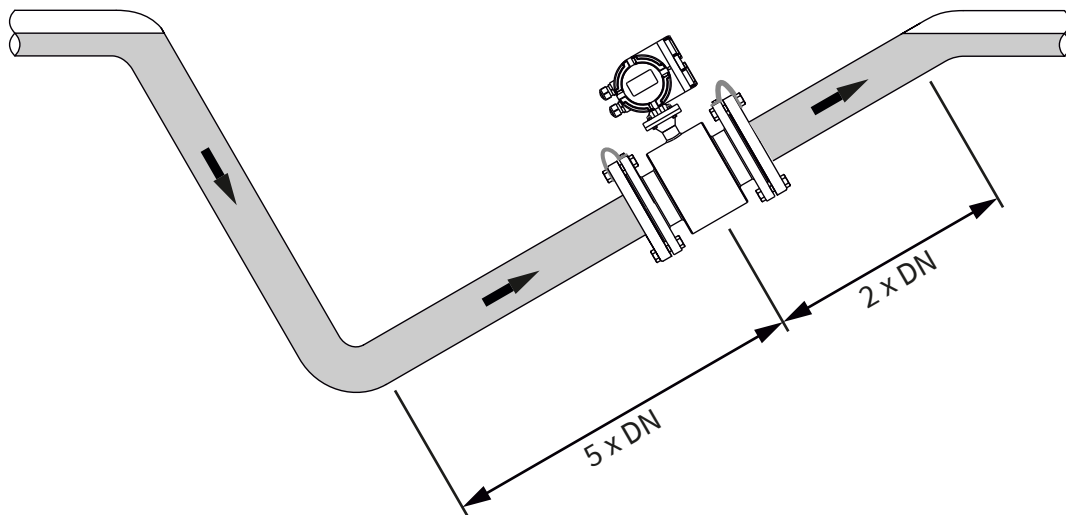

Fig.13-B. Requirement to install the flowmeter straight pipes

The electromagnetic flowmeter must be installed so that the pipe is always completely filled with fluid. In case of partially filled pipe, the flowmeter must be installed as shown in fig. 14-A in order to create a siphon effect and keep the straight pipe always full. See **Fig.14-A**.



**Fig.14-A** Installation in partially filled pipes

The electromagnetic flowmeter must not be installed in the pipe section with a free pipe outlet that could run empty. When installing in a downstream pipe, please make sure the pipe is always fully filled with medium. See **Fig.14-B**.

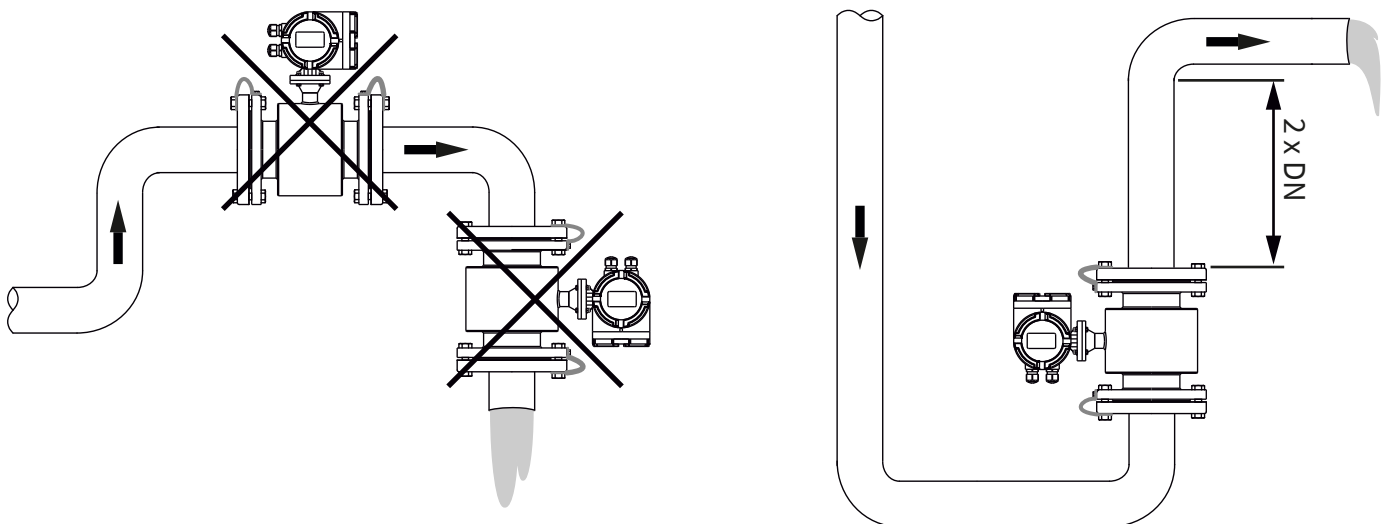

**Fig.14-B** Installation in pipe without emptying

The electromagnetic flowmeter can not be installed at the pipe highest point, because air or gas accumulations may occur in the measuring pipe. See **Fig.15-A**

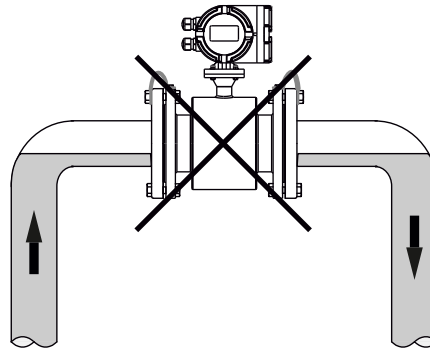

**Fig.15-A** Installation at highest point

The electromagnetic flowmeter can not be installed upstream of a pump to prevent cavitation, which can damage the sensor lining. See **Fig.15-B**

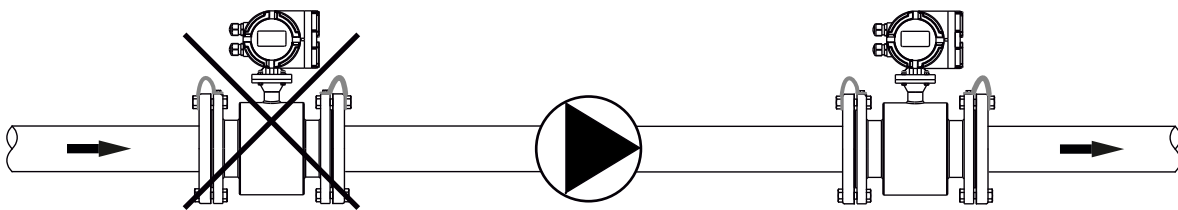

**Fig.15-B** Pump proximity installation

Install a siphon (a) with a vent valve (b) downstream of the sensor in down pipes longer than 5 meters. This precaution is to avoid low pressure and the consequent risk of damage to the lining of the measuring tube. See **Fig.15-C**

**WARNING:** all the phenomena that generate a strong depression inside the pipe can irretrievably damage the insulating coating of the sensor tube itself.

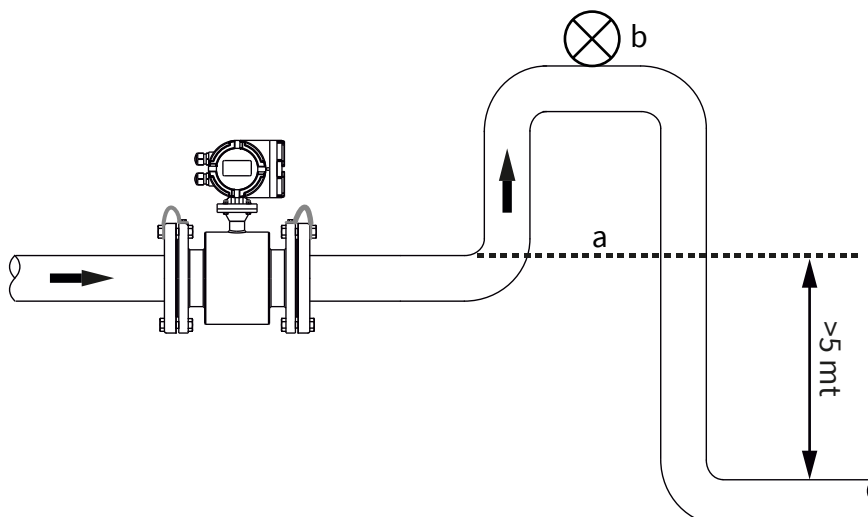

**Fig.15-C** Installation in proximity of a > 5m down pipe section

## 7.6 INSTALLATION PRECAUTIONS

An all-weather cover should be used to protect the housing from the direct sunlight or rain when the device is installed outdoor. Excessive vibrations, large ambient temperature variations and long-lasting showers must be avoided. It should also be protected from leakage of corrosive liquids.

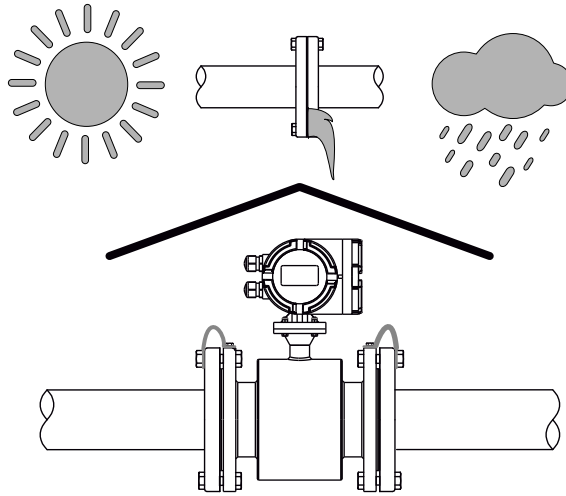

## 7.7 PIPE CONNECTION

The sensor should be supported by the connecting pipes, it cannot withstand its own weight. Mechanical and thermal stress must be avoided.

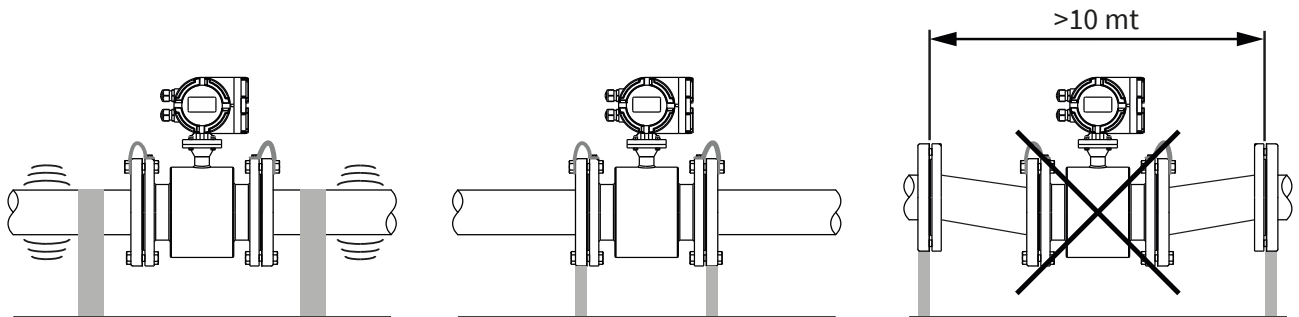

## 7.8 MOUNTING REQUIREMENTS

- a) The sensor pipe and the line pipes must have the same axis. For the sensors under DN50, the axial difference between the measuring tube and operating pipe should be less than 1.5mm; for the sensors from DN65 to DN250, it should be less than 2mm.
- b) The gasket between flanges should have a good corrosion resistance. The gasket must not extend to the pipe inside.
- c) The threads of the fasten bolts and nuts should be in good condition. The bolts should be fastened using torque spanner with certain torque according the size of flange.
- d) It should take separate measure to prevent the lining from heat when weld or flame cutting in the pipe closed to ensor. If the sensor is installed in a well or immersed in water, the connecting box for sensor must be filled and sealed with sealing glue after commissioning.

## 7.9 ACCESSORIES

### 7.9.1 Optional grounding ring

Material: SS 316L or Hastelloy C

Thickness: 2mm

For the non-conductive pipe, the grounding rings should be installed between the flanges of sensor and the pipes in order to keep sensor and measured liquid at the same potential.

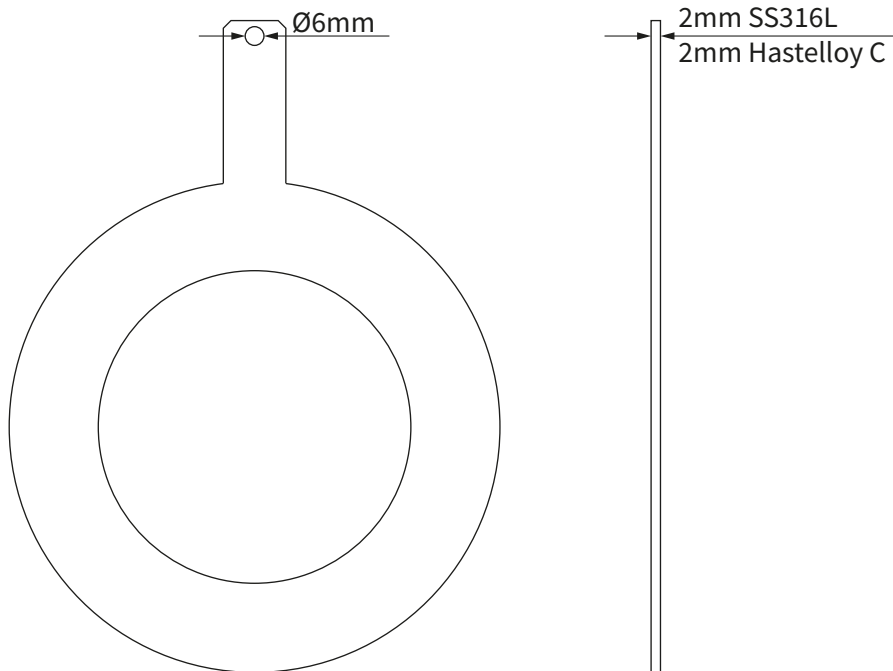

Grounding ring



### 7.10 EQUIPOTENTIALITY AND ELECTRICAL INTERFERENCE REDUCTION

The measuring circuit assumes the fluid at ground potential, as it is in most of application with conductive pipes.

The sensor is isolated from the fluid because of the lining, therefore it's necessary to connect the grounding cables to the pipe's flanges, as shown in fig. 18-A.

The resistance for grounding connection should be less than 10ohm.

Most of application do not require special precautions for installation, the only requirement is to keep the signal cable separate from the main cable. In case of sensor with cathodic protection or electrolysis processes, the main current shall not flow through the measured fluid..

The following measure should be taken in order to reduce the influence of magnetic field:

a) With conductive pipes, potential equalization is made by connecting sensor and the adjoining pipes as shown in figure.

The bolt connection for flanges can not be used instead of the electric connection, it must have an additional electric connection as shown in **Fig.18A**.

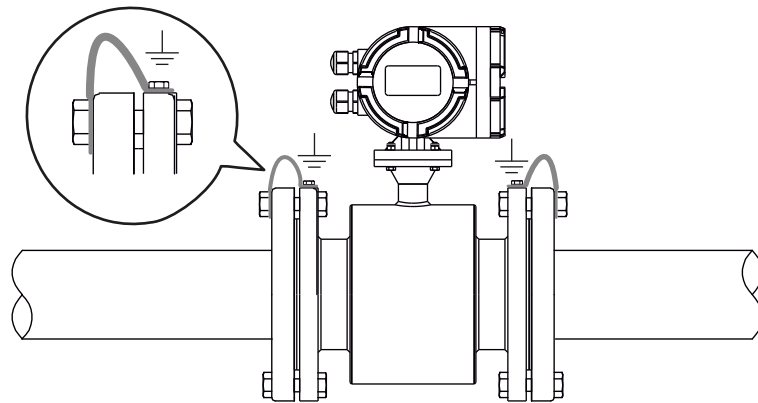

**Fig.18A** Sensor equipotentiality

b) with non-conductive pipes have to use sensor pipe with third electrode or, alternatively, grounding rings must be installed between both sensor flanges and pipes, as shown in **Fig.18-B**.

N.B.: In applications with dark/waste water or similar, the use of grounding rings is recommended.

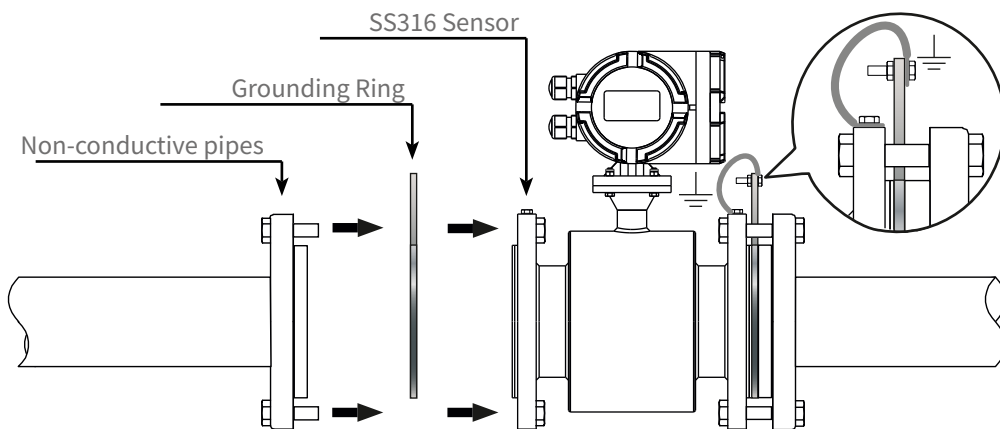

**Fig.18B** Grounding with non-conductive pipes

- c) Some systems, such as pipes with cathodic protection, may be affected by potential disturbance because not all the line is at ground potential. In order to eliminate this type of interference, the line must be isolated with two rubber pipes as shown in **Fig.19A**.

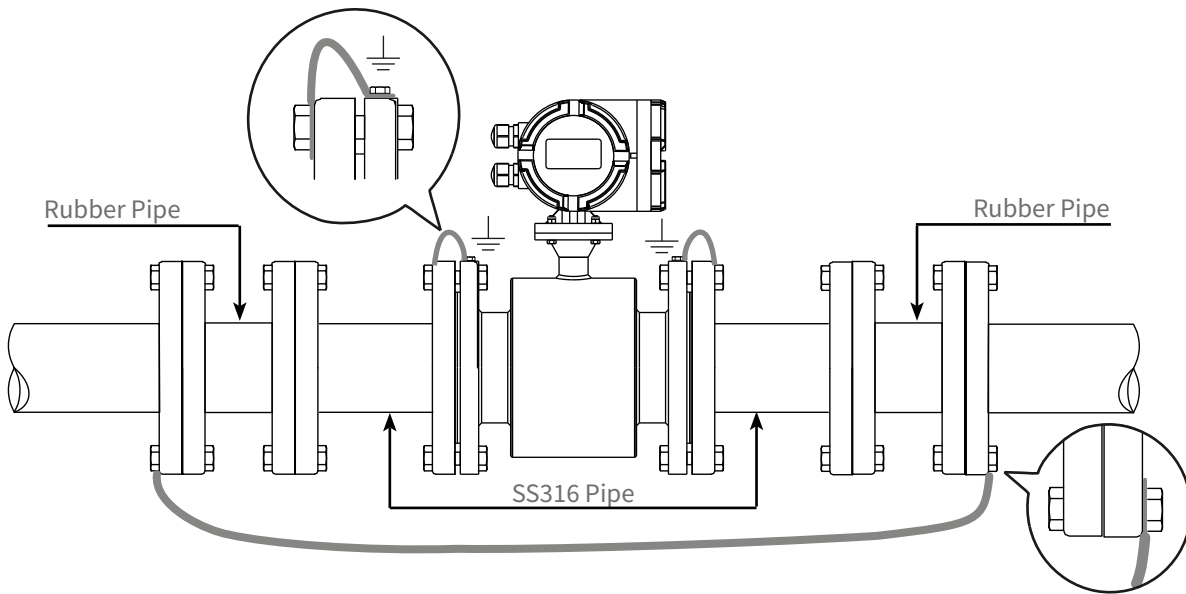

**Fig.19A** Pipe segmentation

### 7.11 PREPARATION FOR OPERATION

*Strictly check the installation and wirings before it gets into operation!*

**It shall be pointed out that the instrument, including the sensor and converter has been fully adjusted, calibrated with actual flow, and inspected under strict measures. All the units are certified. No further adjustments are required when put it into operation. Observe carefully the contents in this manual, to check and analyze any malfunction**

*The following steps have to be followed to get the instrument into operation.*

- 1) Make sure that the sensor is completely filled with fluid.
- 2) Turn the power supply ON. After approx. one minute, the display will show a value which indicates that the wire connection is correct. If the flow value is negative, it can be adjusted via the "flow direction" parameter.
- 3) Zero verification. Shut off the valve tight in downstream first and then the valve in upstream, to let the liquid stops to flow in the pipeline. The displayed value should be 0. The value displayed can be corrected at the converter if the value is different than 0.

### 7.12 MAINTENANCE

Generally, no extraordinary maintenance is needed on magnetic flowmeter.

Only in case the product can adhere to the inner wall of the sensor, and its electrodes, it is necessary to perform periodic cleaning operations.

***Be careful not to damage the lining and the electrodes.***

## 8-ELECTRICAL CONNECTIONS

### 8.1 CABLE ENTRY

The compact version converter enclosure has n. 2 M20x1.5 cable glands.

The converter enclosure remote version has n.2 M20x1.5 cable glands for power supply and outputs signal, and 2 M16x1.5 cable glands for sensor pipe connection

### 8.2 ELECTRICAL CONNECTION REQUIREMENTS

Before making the electrical connections, consider the following standards and be sure to have the correct power supply, ducts and other accessories.

#### 8.2.1 Power supply voltage

RPmag transmitter is designed to be powered with  $85 \div 265\text{Vac}$  (50 to 60 Hz), 24Vdc/ac, 12Vdc voltage.

#### 8.2.2 Power supply voltage interruption

Power supply wires must be connected to the device via a circuit breaker or an external disconnecting switch.

The switch or circuit breaker should be clearly labeled and located close to the transmitter.

#### 8.2.3 Infiltration and humidity prevention

To avoid the humidity infiltration inside the converter and sensor pipe is recommended:

- Caps and cable glands must be well tightened.
- position the cable so that it forms a downward curve at the M20x1.5 and/or M16x1.5 output (see below figure); in this way the condensation and/or rain water will tend to drip from the curve bottom.



### 8.3 POWER CONNECTION

To connect the power supply to the meter, complete the following steps:

- 1) Open the box connections cover.
- 2) Insert the power supply cable through the cable gland.
- 3) Follow the sequent list to connect the power supply cable:

#### AC Units:

- Connect the GND grounding terminal  $\perp$
- Connect the wire to terminal **N**.
- Connect the phase to terminal **L**.

#### DC Units:

- Connect the GND grounding terminal  $\perp$
- Connect + 24Vdc or 12Vdc to terminal **L (+)**.
- Connect 0V to terminal **N (-)**.

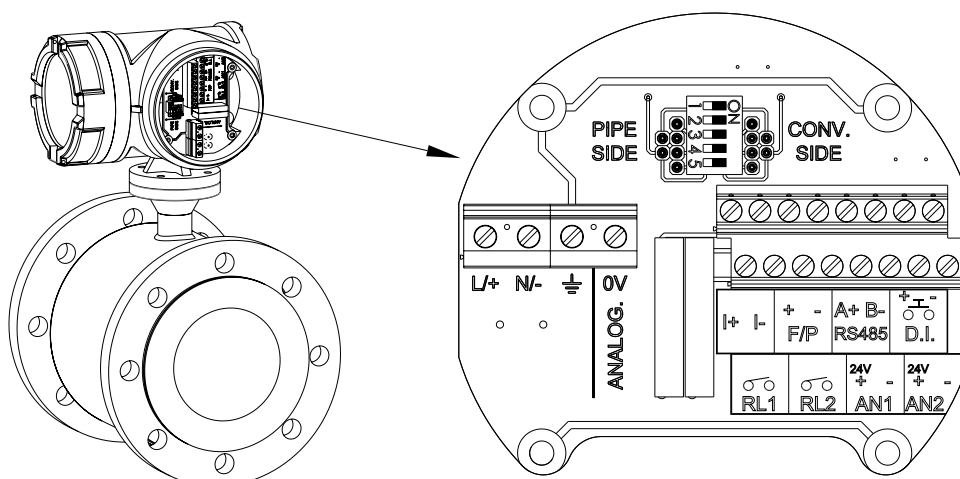

### 8.4 Dip-Switch configuration

For the Rpmag flowmeter proper operation, the dip-switch relative to the interface connection to the external diagnostic unit must be set to “ON” as shown in the following drawing

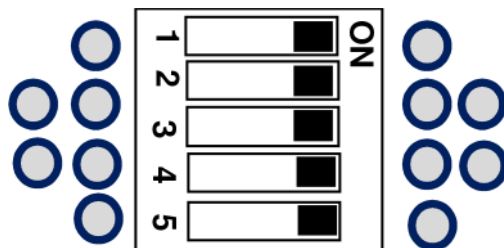

### 8.5 OUTPUT

To connect the analog and/or impulsive output follow the instructions of the following points

#### 8.5.1 Analog output

The current output is powered from the transmitter.

The circuit resistance must be equal to or less than 500ohm.

Follow the below steps to connect the signal cable to the transmitter:

- 1) Insert the signal cable through the cable gland.
- 2) Connect the two wires to **I+** and **I-** terminals

The below drawing shows the connection diagram between the RPMAG flowmeter and SLM2XH3 flow totalizer unit.

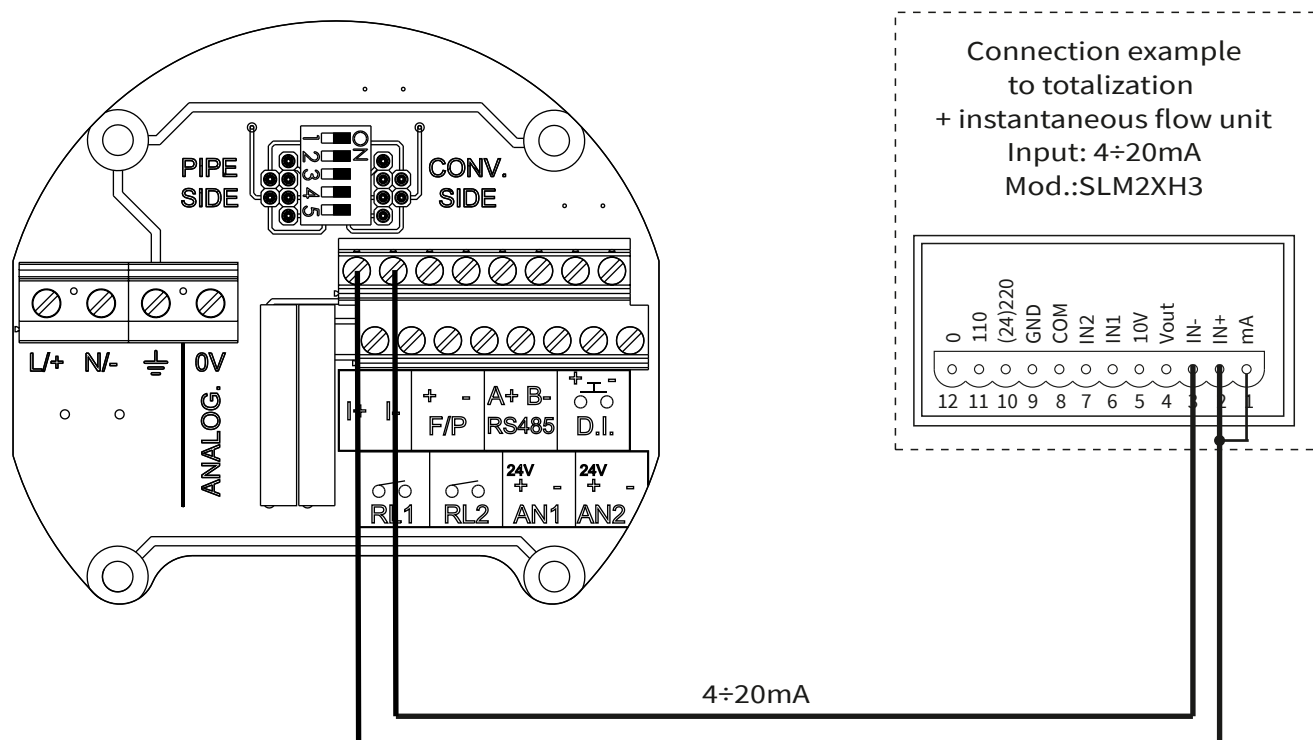

**8.5.2 Digital output**

When digital output is set in frequency mode, it generates an 0.1÷10000Hz output signal proportional to the measured flow rate; however if it's set in pulsed mode it generates a single pulse every certain step of totalizer increase. The signal is normally used in combination with an external totalizer, a pulse counter or an acquisition system. The resistance in the circuit must be equal to or greater than 100Kohms.

Follow the below steps to connect the signal cable to the transmitter:

- 1) Insert signal cable through the cable gland.
- 2) Connect two wires to F/P+ and F/P- terminals

N.B. - When the Rpmag pulse output is connected to an acquisition system that requires a current higher than 11mA, a properly sized pull-up resistor must be connected to ensure the minimum current required by the acquisition system connected (see drawing below); example: if the acquisition system requires a min. current of 15mA, a 1,6 Kohm pull-up resistor must be connected (according to the calculation  $R = V / I = 24V / 15mA = 1,6Kohm$ ) between an external power supply of 24 Vdc and the acquisition system input terminal

The below drawing shows the connection diagram between the RPMAG flowmeter and the 199-B1X counter unit

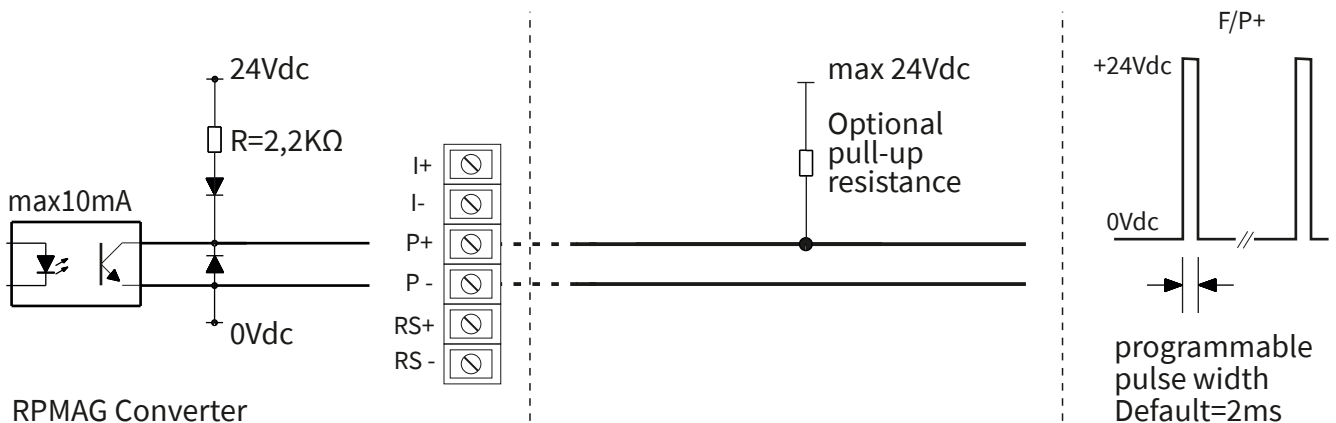
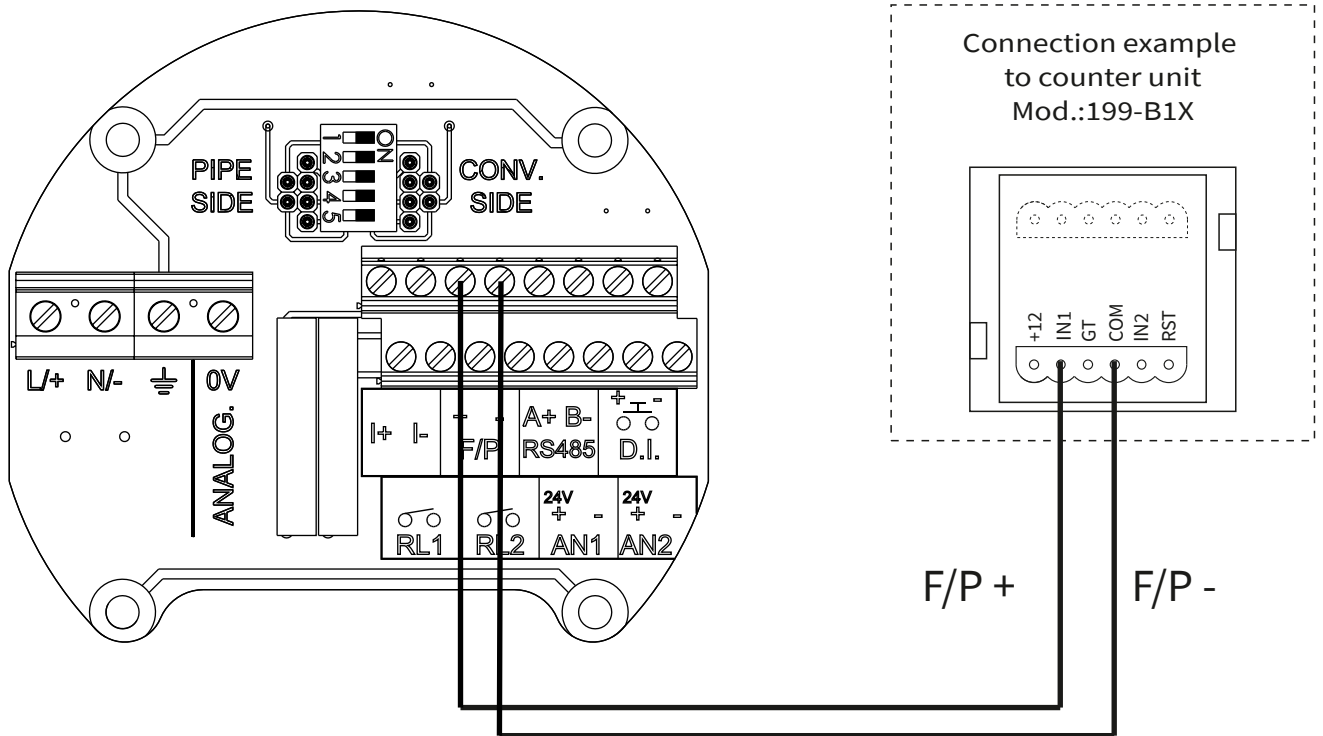

### 8.5.3 Alarm output

Follow the below steps to connect the signal cable to the transmitter:

- 1) Insert the signal cable through cable gland.
- 2) Connect two wires to **RL1**, for the #1 alarm threshold, and **RL2** terminals for #2 alarm threshold.

The below drawing shows the connection diagram between the RPMAG flowmeter and the 199-B2X multifunction counter unit.

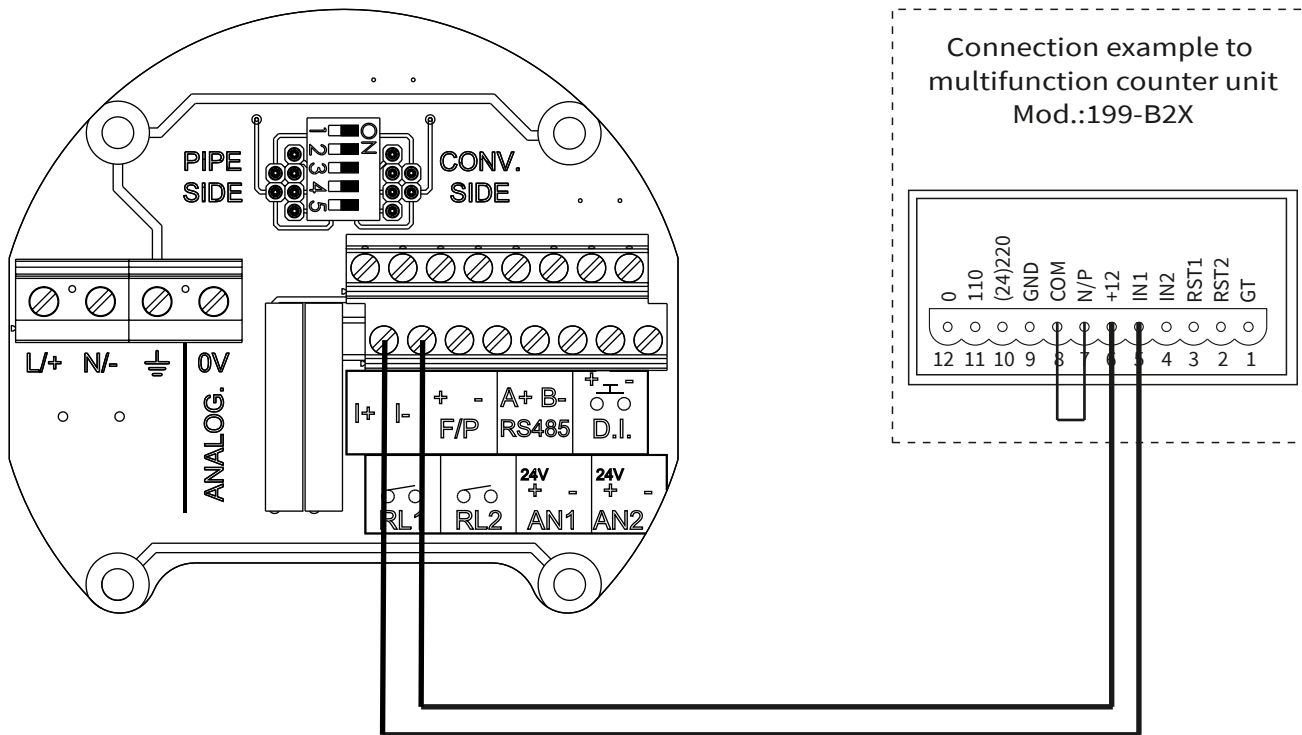

### 8.5.4 RS485 serial output

Communicate via MODBUS RTU is possible in models with RS485 serial port.

Connect the serial cable to **A+** and **B-** terminals

The below drawing shows connection example diagram between RPMAG flowmeter and a PC.

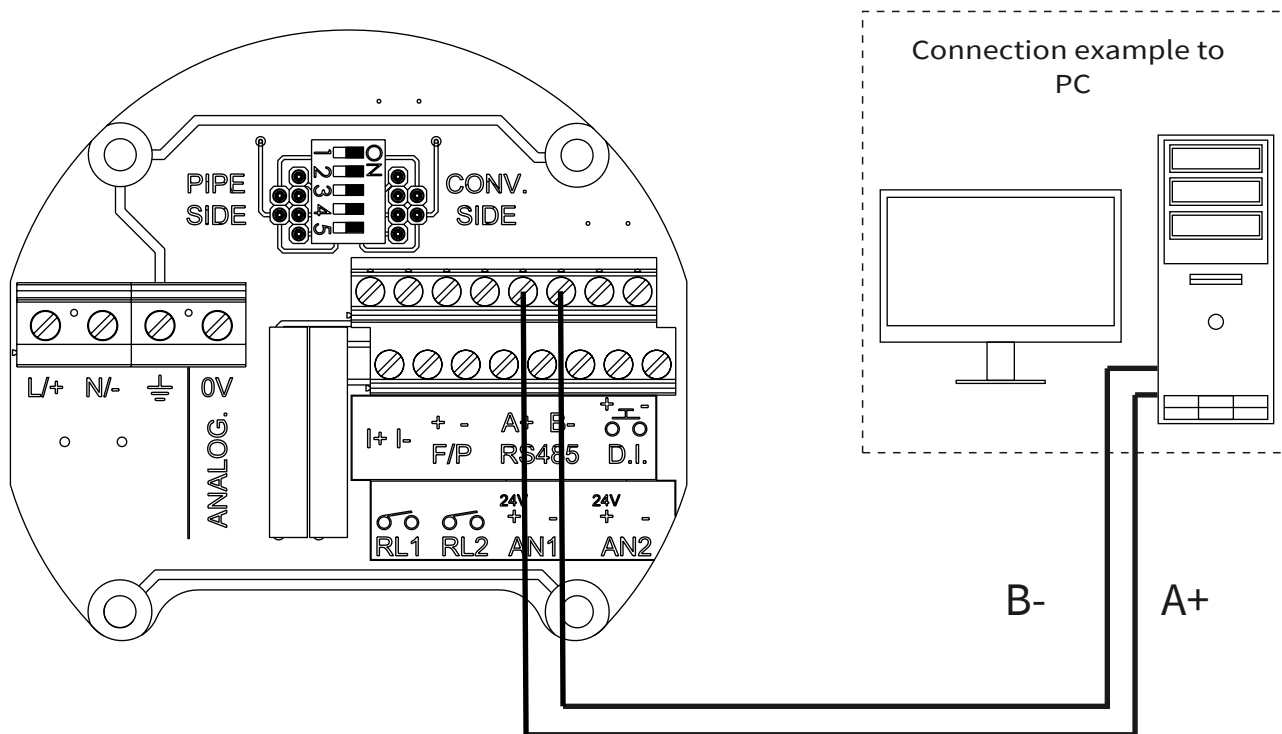

**8.7 REMOTE VERSION**

During the remote version installation comply with the following information to ensure correct measurements:

- 1) The cables must be as short as possible, especially with low conductivity fluids.
- 2) The cables should be far from electrical machinery and switching devices such as contactors or solenoid valves.
- 3) The cables must not be in conduit with power cables or cables for the switching devices control.
- 4) When necessary, ensure the equipotential between sensor and transmitter.
- 5) The maximum cable length is a fluid conductivity function. Refer to paragraph 8.7.2.

Connect the sensor to the converter according to the below diagram.

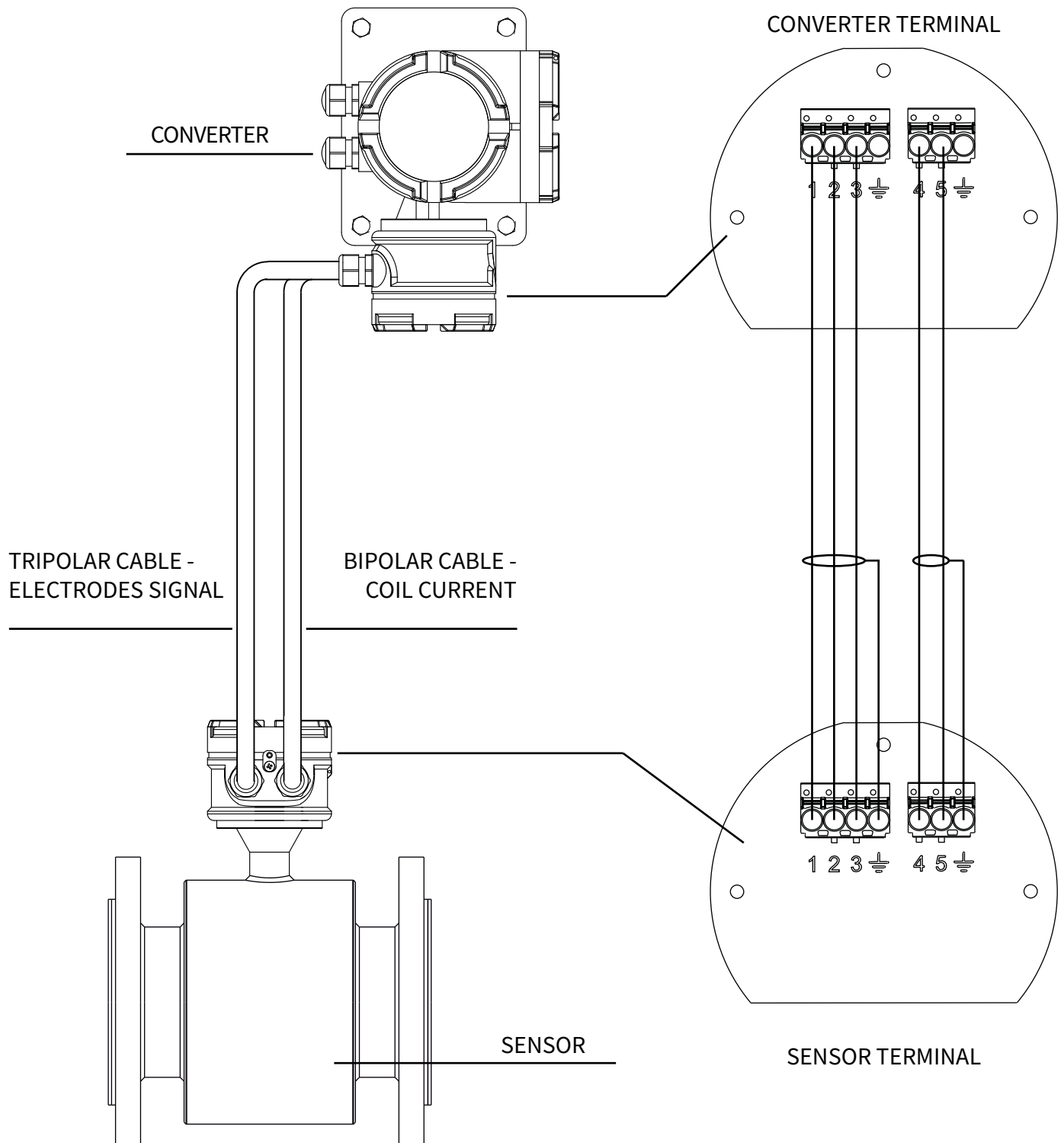

### 8.7.1 Remote version wiring

Cable	Wire		Function	Terminal position
	Num.	Color		
Bipolar	4	black	coil	4
	5	brown	coil	5
	braid		shield	$\perp$
Tripolar	1	white	electrode 1	1
	2	yell./green	common GND	2
	3	brown	electrode 2	3
	braid		shield	$\perp$

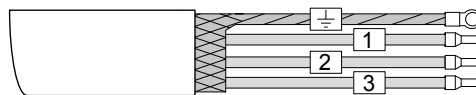

SHIELDED TRIPOLAR CABLE

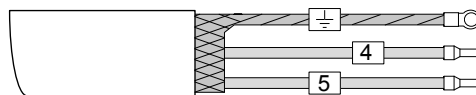

SHIELDED BIPOLAR CABLE

### 8.7.2 Connecting cables length

Maximum length of the connecting cables between the sensor and the convertor is determined by the fluid conductivity value.

In the graph below the gray highlighted area indicates the allowed cable length in relation to the fluid conductivity value. With an 150 microS fluid conductivity, for example, the connection cables will have a maximum length of 150 meters.

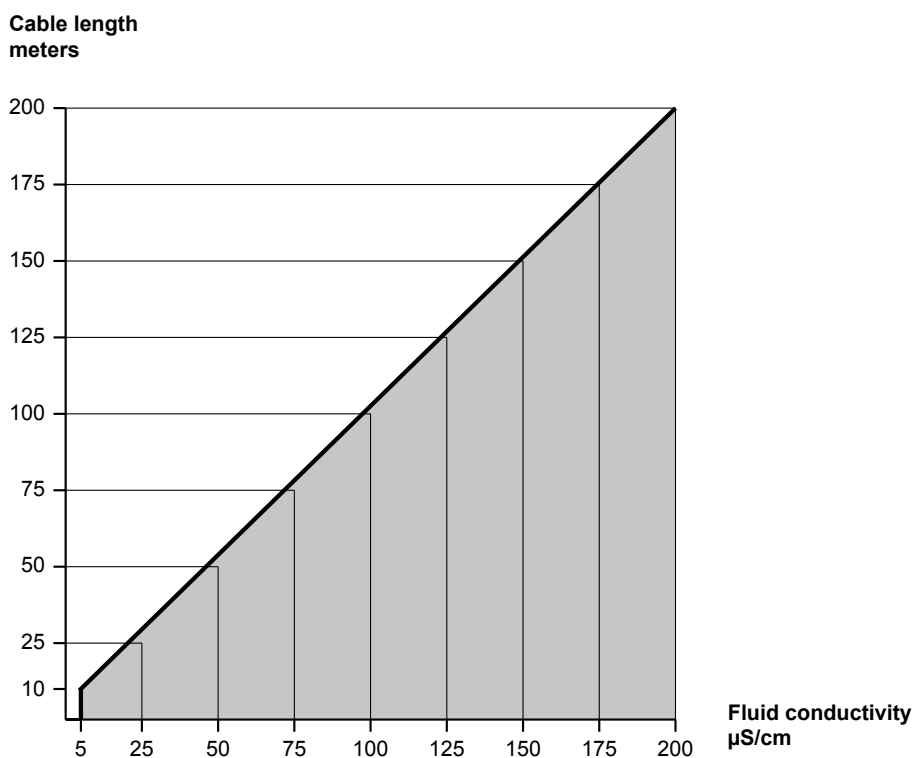



### 8.7.3 Connecting cables

#### 8.7.3.1 - Coil cable technical specification

Shielded bipolar cable FR20H2R 2x1.5 section	
Conductors	Tinned copper stranded wire, class 5
Insulations	PVC R2 Ø 2,8mm ± 0,1
Conductors Colors	Black - Brown
Cable stranding	Concentric with polyester tape
Shielding	Tinned copper braid
Sheath	PVC RZ resistant to hydrocarbons; Ø 8,2mm ± 0,30; Black
Marking	525B005A
Operating temperature	-25÷+70°C (fixed installation)
Test voltage	3KV V.c.a.
Working voltage	450/750V
Conductors electrical resistance	CEI 20-29
Reference Standards	CEI 20-22 II-IEC 332.3A-ROHS 2011/65/UE(ROHS 2)

#### 8.7.3.2 - Electrodes signal cable technical specification

Shielded tripolar cable FR20H2R 3x1.5 section	
Conductors	Tinned copper stranded wire, class 5
Insulations	PVC R2 Ø 2,8mm ± 0,1
Conductors Colors	White - Brown - Yellow/Green
Cable stranding	Concentric with polyester tape
Shielding	Tinned copper braid
Sheath	PVC RZ resistant to hydrocarbons; Ø 8,2mm ± 0,30; Black
Marking	525B004A
Operating temperature	-25÷+70°C (fixed installation)
Test voltage	3KV V.c.a.
Working voltage	450/750V
Conductors electrical resistance	CEI 20-29
Reference Standards	CEI 20-22 II-IEC 332.3A-ROHS 2011/65/UE(ROHS 2)

## 9-LOCAL OPERATOR INTERFACE (LOI)

LOI is an operator communications center for the Rpmag. Through the LOI, the operator can access any transmitter function for changing configuration parameter settings, checking totalized values, or other functions.

### 9.1 SAFETY MESSAGES

Instructions and procedures in this section may require special precautions to ensure the safety of the personnel performing the operations. Information that raises potential safety issues are indicated by a warning symbol.

Please refer to the following safety messages before performing an operation preceded by this symbol: 

### 9.2 WARNINGS

#### Explosions could result in death or serious injury

- Verify that the area of installation and operation comply with the characteristics of the measuring tube and the transmitter.
- Make sure only qualified personnel perform the installation.
- Do not perform any service other than those contained in this manual.









#### High voltage that may be present on leads could cause electrical shock

- Avoid contact with leads and terminals.

### 9.3 LOI Features

The LOI is implemented through VL701, a detachable display with 4 buttons which allows to perform all operational, control and programming instrument functions.

In the configuration menus, it's possible:

1. Submenus and parameters access; press  to select and press  to access.
2. Parameter options choice: press  to select the option and press  to store the option. Press  to exit without saving.
3. Configure the parameter values; in some parameters the configuration is done by setting a value (eg, in the MAX FLOW parameter is possible to change the number):  
press  to select the digit to be modified (the digit is highlighted in inverse), press  to change the highlighted digits number, press  save the set value and exit automatically. Press  to exit without saving.



- Exit configuration
- Back to previous menu



- Parameters values modification



- Scroll cursor (to the right)
- Scroll parameters



- Configuration access
- Options confirmation
- Parameters values confirmation

### 9.4 VL701 DISPLAY MODULE

The VL701 programming module can be mounted and removed from the Rpmag without affecting the unit operation. Unscrewing the cover, the VL701 module can be mounted (by clockwise rotation until it clicks) or dismantled (by rotation counterclockwise) as shown in figure.

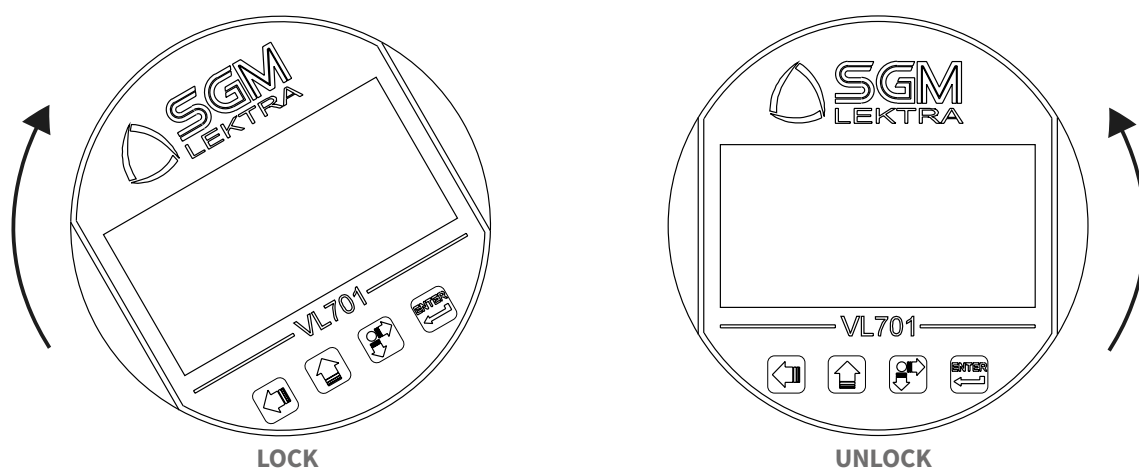

### 9.5 DISPLAY ROTATION

If it is necessary the display can be rotated, as indicated in the following procedure:

1. ⚠ Disconnect power supply from transmitter.
2. Unscrew the transparent cover.
3. Remove the two screws that secure the “display/electronics” bracket to the container, paying attention to the wiring between the electronics and the terminal.
4. Rotate the display / electronics bracket to set the position (minimum 90° rotation).
5. Tighten the two screws that secure the “display/electronics” bracket to the container.
6. Tighten the transparent cover.

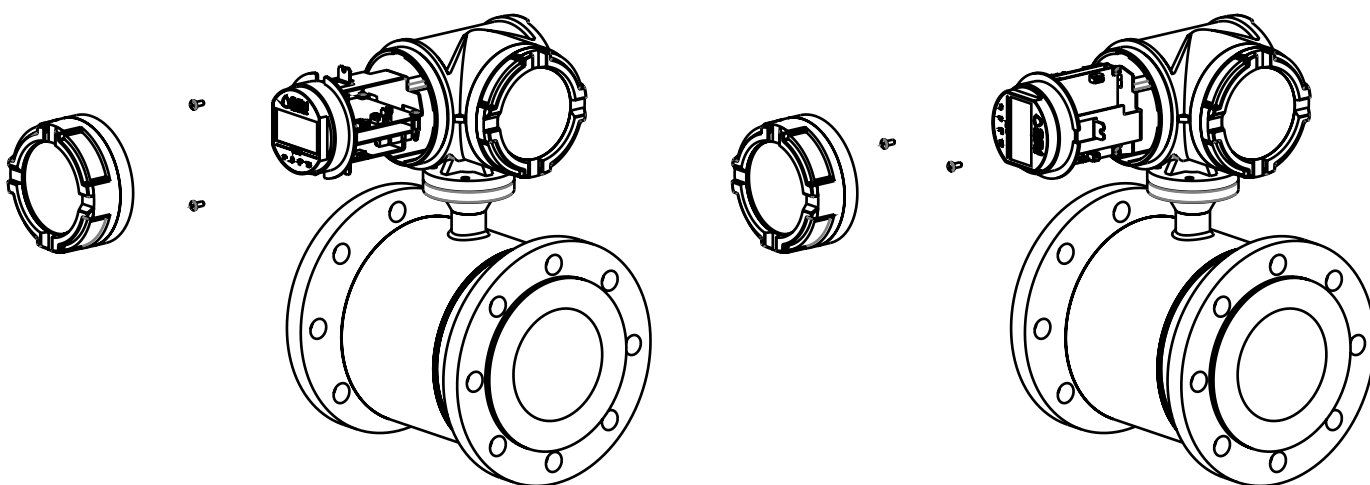

### 9.6 INTERNAL DATA LOGGER USB PORT

The USB port is used to connect the pen drive, necessary for the internal event counter variation data logger. Customer must not remove the pen drive for any reason.

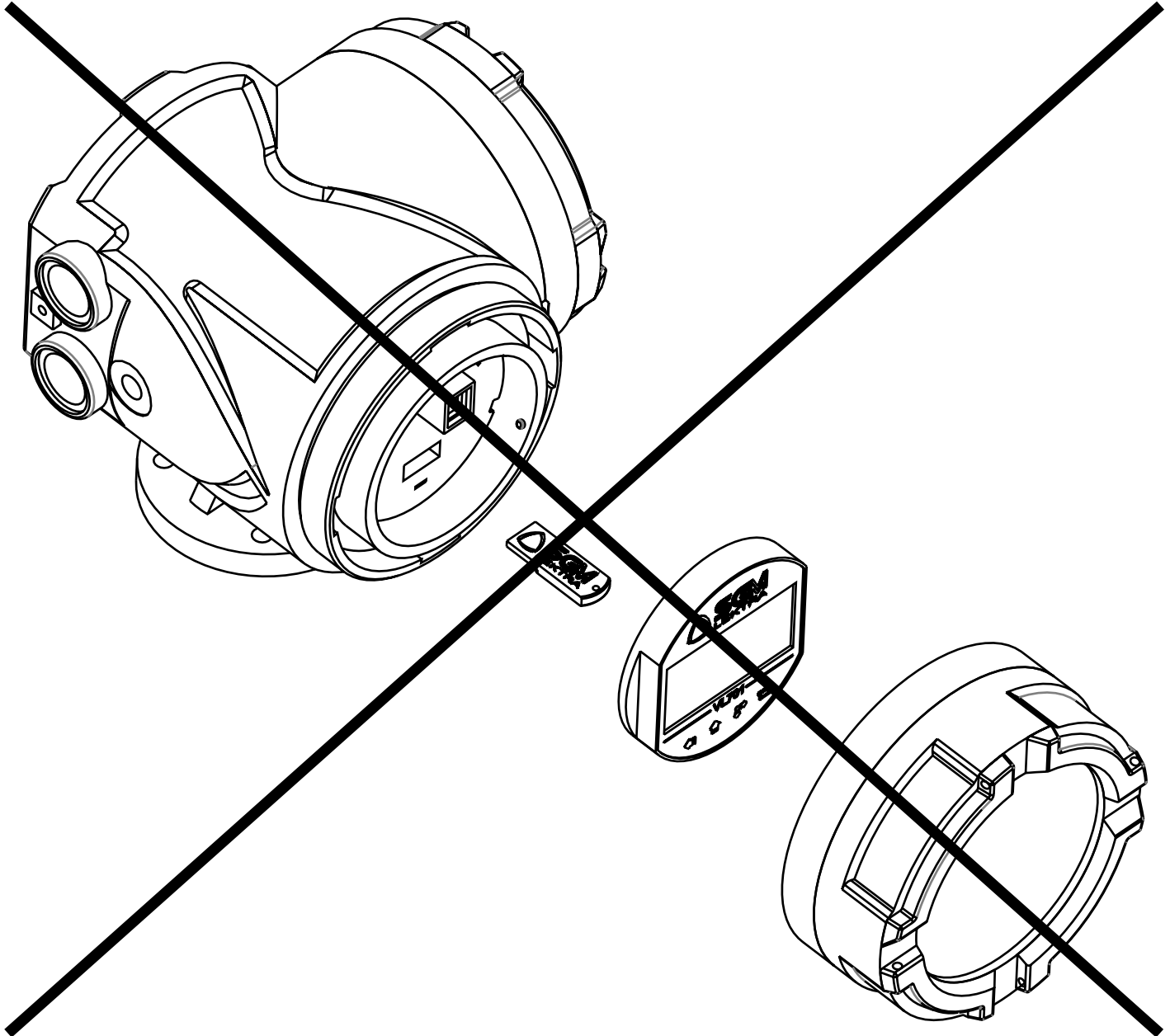

### 9.7 CONVERTER ROTATION

To a greater functionality and adaptation to the application the entire converter, in addition to the display, can be rotated by following the below steps:

 Disconnect the power supply voltage.

1. Remove the four screws that secure the converter to the sensor pipe.
2. Slightly lift the converter paying attention to the electrical connections between the sensor pipe and the terminal.
3. Turn the converter (minimum 90° rotation) bringing it to the desired position.
4. Fix the converter to the sensor with the 4 fixing screws.

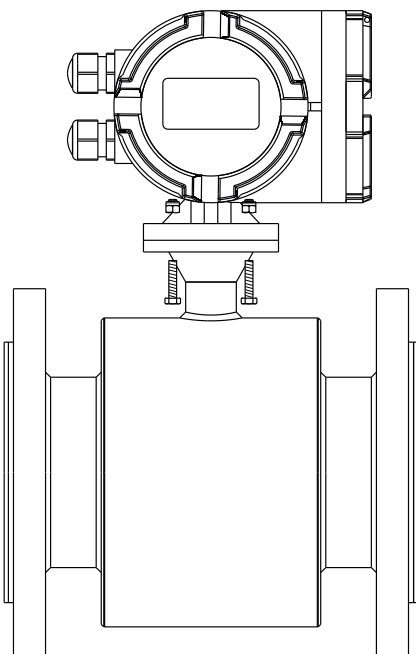
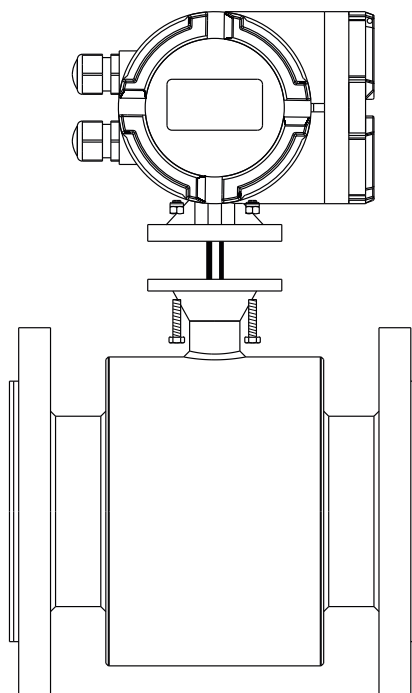
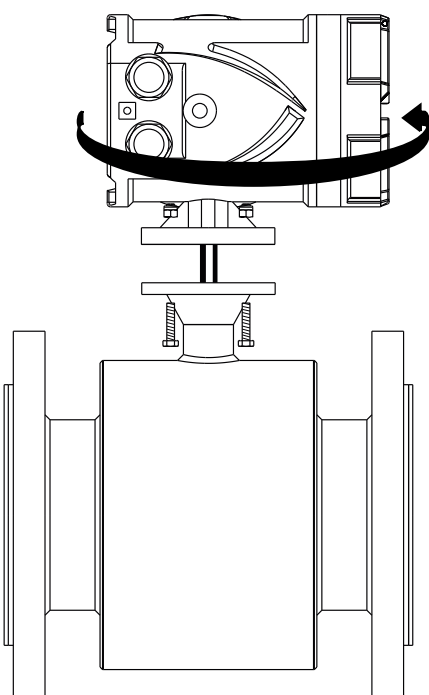
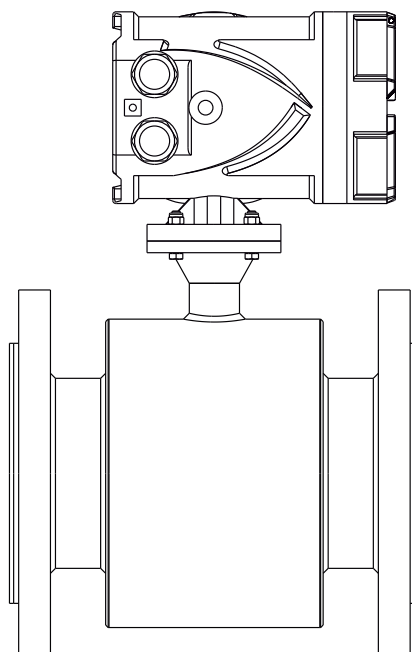
**1****2****3****4**

## 10-PROGRAMMING

### 10.1 DATA ENTRY

The LOI keypad has no numerical keys. Enter numerical data using the following procedure:

1. Access the appropriate function.
2. Use SCROLL to highlight the digit you want to enter or change.
3. For numerical data, UP ARROW scrolls the digits from 0 to 9  
(UP ARROW or SCROLL are also used to toggle pre-determined choices that do not require data entry).
4. Use SCROLL to highlight and change other digits you want to change.
5. Push ENTER to confirm data entry.

### 10.2 KEYBOARD LOCK

Simultaneously pressing the LEFT ARROW and SCROLL keys from RUN mode, for 5 seconds, keyboard will be locked. Display will show PADLOCK simbol.

Simultaneously pressing the LEFT ARROW and SCROLL keys from RUN mode, for 5 seconds, keyboard will be un-locked.

### 10.3 DISPLAY PAGES

The Rpmag, in RUN mode, has three pages to display data and status, press UP ARROW to manually change page. The pages will automatically alternate every 21S.

#### 10.3.1 MAIN PAGE

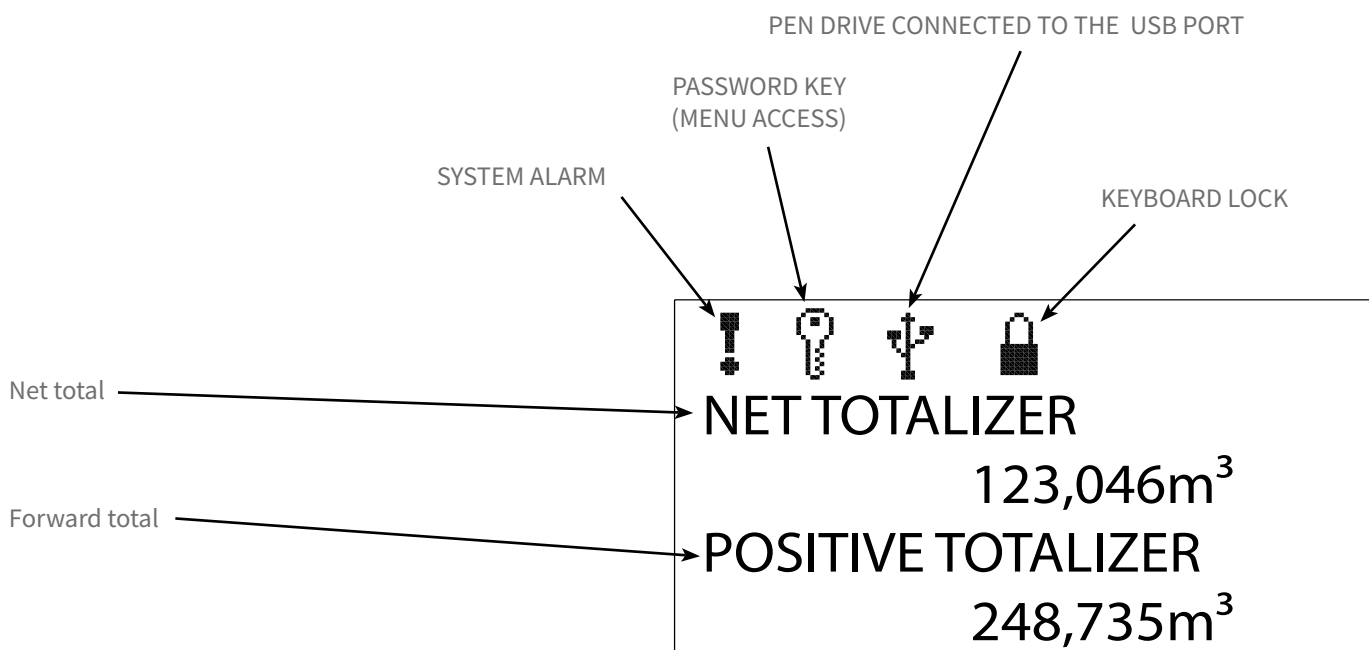

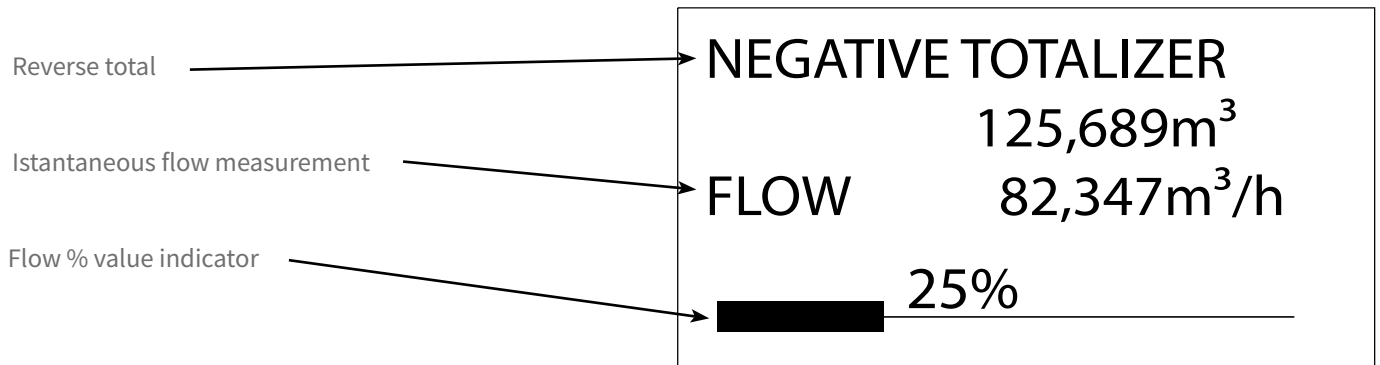
**10.3.2 SECOND PAGE****10.3.3 THIRD PAGE**

- Flowmeter serial number
- Event number of the flow measurement parameters changing
- Sensor pipe DN
- Firmware version
- Configuration index
- Range ability
- Sensor Factor value

SN FM0000000  
 Event Counter  
 DN 100 mm  
 FW 2.05MID  
 IC 0.0.00  
 Q3/Q1 200.00  
 SENSOR K 0,05755

**10.3.4 ALARMS PAGE**

The symbol “!” will be displayed when there are system alarms.  
 Press SCROLL to access the alarms page.

Press SCROLL again to return to the main page (MAIN)  
 Press ENTER to clear the error history (CLEAN)

**EMPTY PIPE**

**MAIN CLEAN**

**10.4 LOI MENÙ**

Press ENTER key from run mode and enter the password “1000” (the key symbol will appear on the display).

Press ENTER to access the programming menu: display will show the list of configuration menu as shown here next.

Press UP ARROW or SCROLL keys to select the desired menu, then press ENTER key to access.

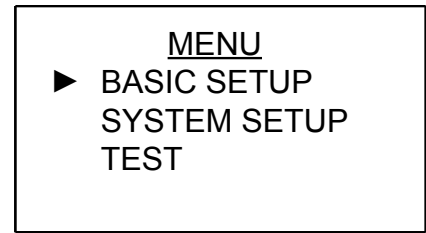
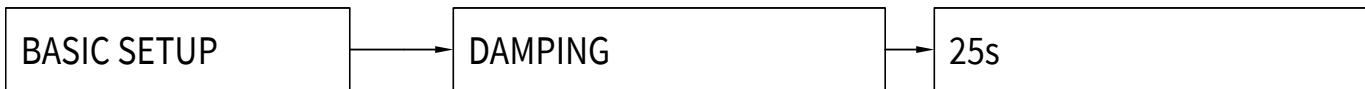
**10.4.1 BASE SETUP menu****10.4.1 BASIC CONFIGURATION (BASIC SETUP)**

Press ENTER key from run mode, the display will be as shown here next, then press ENTER to enter in “BASIC SETUP” menu.

Press UP ARROW or SCROLL keys to select the desired function and press ENTER key to access.

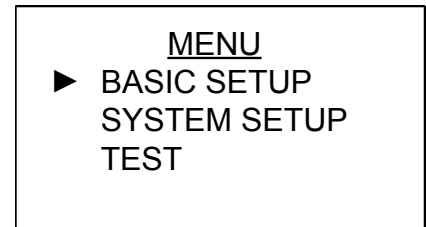
**10.4.1.1 -DAMPING**

it sets the integration time for measurement.  
Lower values mean fast response, higher values are suggested for reduction of fluctuations in flow measurement.  
Default: 25s;  
Range: 1÷100s

Press ENTER key, the display will be as shown here next.  
With UP ARROW or SCROLL select the option.

Press ENTER to confirm. The ☺ to confirm the parameter edit storage.

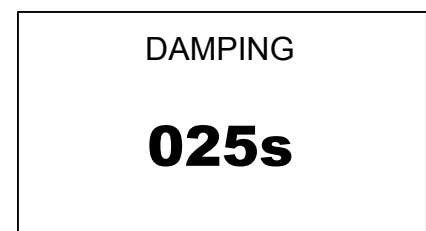
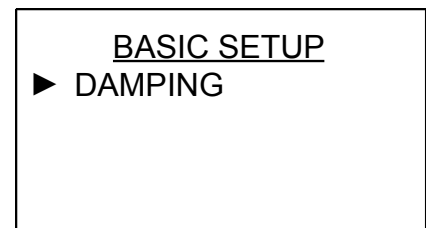



## 10.4.2 SYSTEM SETUP

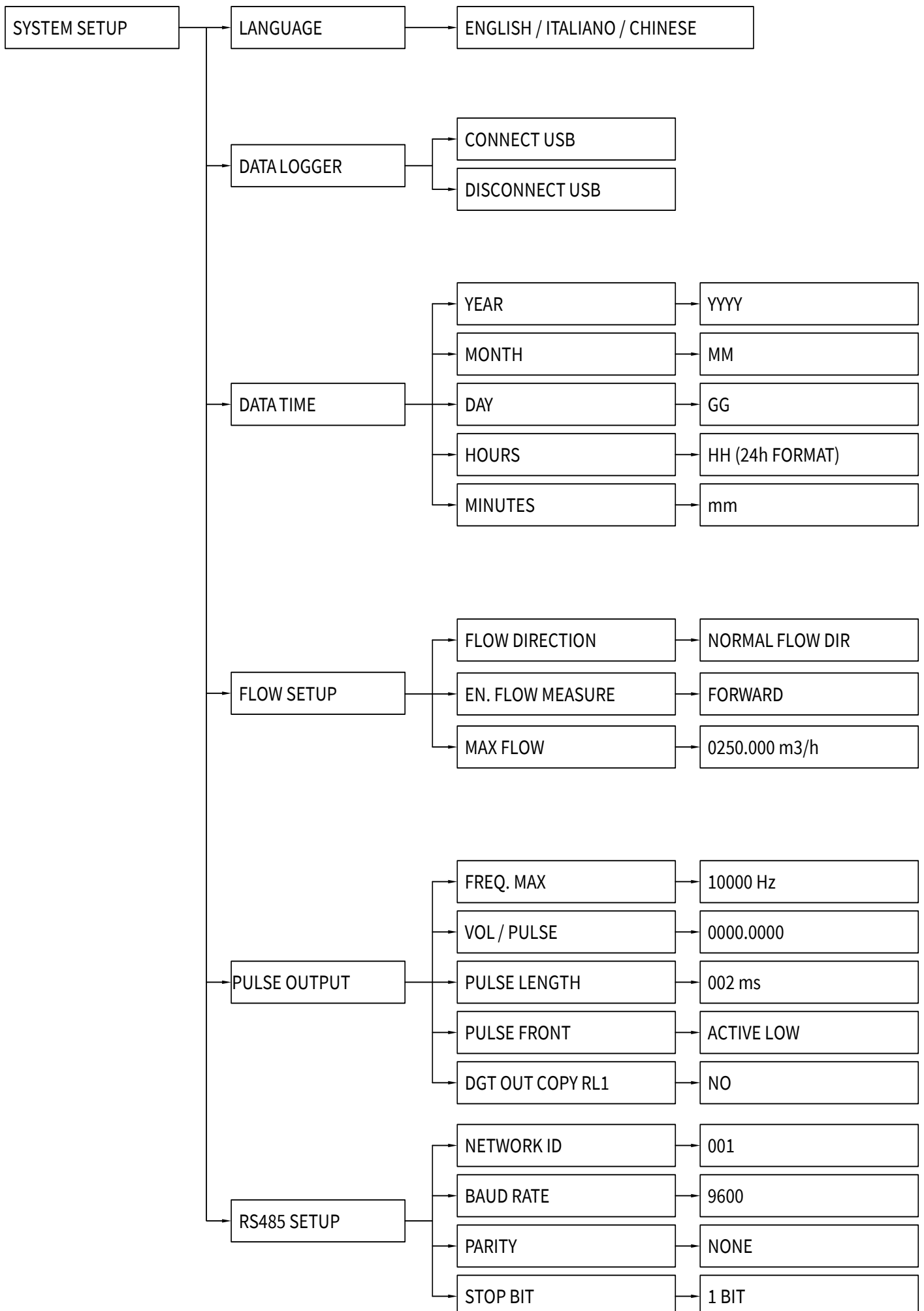

**10.4.3 SYSTEM CONFIGURATION (SYSTEM SETUP)**

Press ENTER key from run mode: the display will be as shown here next, then press SCROLL key to select "SYSTEM SETUP" menu and press ENTER to enter.

Press UP ARROW or SCROLL keys to select the desired function and press ENTER key to access.

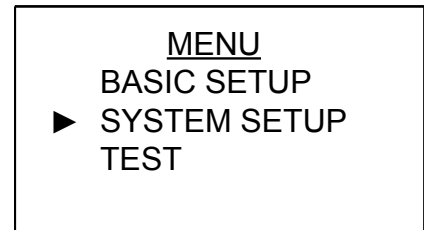
**10.4.3.1 LANGUAGE**

Allows menu language selection.

Default: ENGLISH; Range: ENGLISH - ITALIANO - CHINESE

Press ENTER key, the display will be as shown here next.

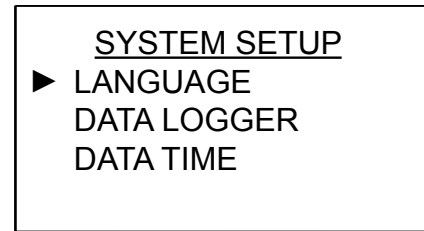

With UP ARROW or SCROLL select the option.  
Press ENTER to confirm.

The 😊 to confirm the parameter edit storage.

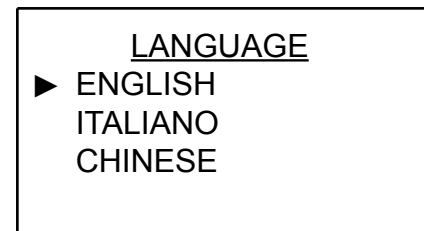
**10.4.3.2 - DATA LOGGER**

The USB pen drive data logger function is set in this menu.  
Press ENTER to confirm.

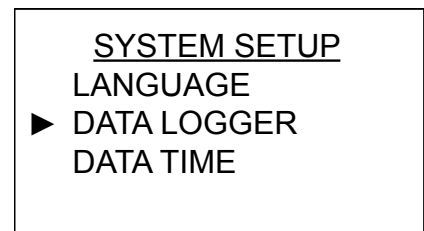

The display will be as shown here next.  
Press UP ARROW or SCROLL keys to select the desired function and press ENTER key to access.

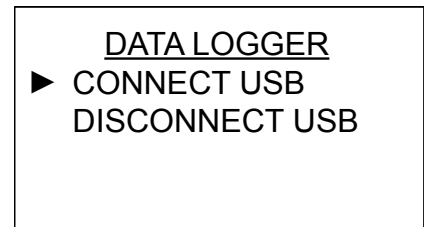
**10.4.3.2.1 CONNECT USB**

Connect the pen drive to the USB port.

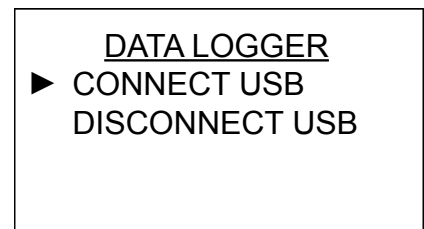

Press ENTER, after the "WAIT" message, the "USB CONNECTED" message will appear. If the "USB NOT FOUND" message is displayed, verify that the pen drive is properly inserted into the USB port.

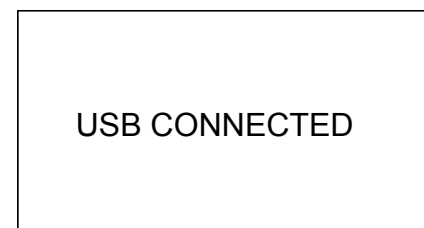

**10.4.3.2.2 - DISCONNECT USB**

Disconnect the pen drive to the USB port.

Press ENTER ,after the “WAIT” message, the “REMOVE USB “ message will appear”.

**10.4.3.3 - DATE TIME**

In the system clock and the calendar are set in this menu.

The display will be as shown here next.  
Press UP ARROW or SCROLL keys to select the desired function and press ENTER per accedervi.

**10.4.3.3.1 YEAR**

Sets the year in the YYYY format.

Press ENTER key, the display will be as shown here next.  
With UP ARROW change the digit, with SCROLL moves the cursor.  
Press ENTER to confirm.  
The ☺ to confirm the parameter edit storage.

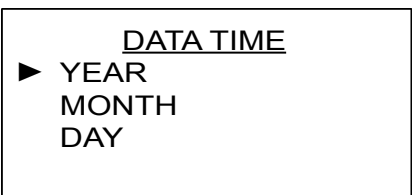
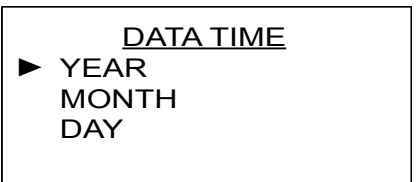
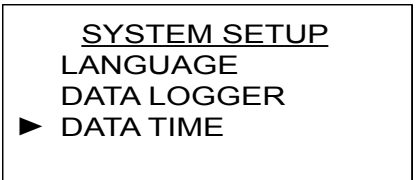
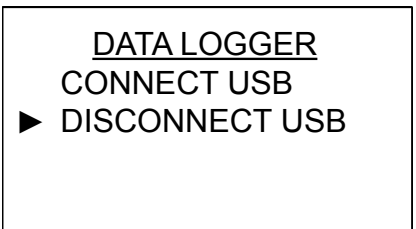

**10.4.3.3.2 MONTH**

Sets the month in the MM format.

Press ENTER key, the display will be as shown here next.  
 With UP ARROW change the digit, with SCROLL moves the cursor.  
 Press ENTER to confirm.  
 The ☺ to confirm the parameter edit storage.

DATA TIME  
 YEAR  
 ► MONTH  
 DAY

MONTH  
**02**

**10.4.3.3.3 DAY**

Sets the day in the dd format.

Press ENTER key, the display will be as shown here next.  
 With UP ARROW change the digit, with SCROLL moves the cursor.  
 Press ENTER to confirm.  
 The ☺ to confirm the parameter edit storage.

DATA TIME  
 YEAR  
 MONTH  
 ► DAY

DAY  
**12**

**10.4.3.3.4 HOURS**

Sets the hours in the HH format.

Press ENTER key, the display will be as shown here next.  
 With UP ARROW change the digit, with SCROLL moves the cursor.  
 Press ENTER to confirm.  
 The ☺ to confirm the parameter edit storage.

DATA TIME  
 MONTH  
 DAY  
 ► HOURS

HOURS  
**16**

**10.4.3.3.5 MINUTES**

Sets the minutes in the mm format.

Press ENTER key, the display will be as shown here next.  
 With UP ARROW change the digit, with SCROLL moves the cursor.  
 Press ENTER to confirm.  
 The ☺ to confirm the parameter edit storage.

DATA TIME  
 DAY  
 HOURS  
 ► MINUTES

MINUTES  
**48**

**10.4.3.4 FLOW SETUP**

The configuration parameters of the flow measurement are set in this menu.

Press ENTER to access.

The display will be as shown here next.

Press UP ARROW or SCROLL keys to select the desired function and press ENTER key to access

```

SYSTEM SETUP
DATA LOGGER
DATA TIME
▶ FLOW SETUP
  
```

```

FLOW SETUP
▶ FLOW DIRECTION
EN. FLOW MEASURE
MAX FLOW
  
```

**10.4.3.4.1 FLOW DIRECTION**

Sets the positive flow direction with respect of the arrow on sensor pipe.

Default: NORMAL FLOW DIR

Range: NORMAL FLOW DIR; INVERT FLOW DIR

```

FLOW SETUP
▶ FLOW DIRECTION
EN. FLOW MEASURE
MAX FLOW
  
```

Press ENTER key, the display will be as shown here next.

With UP ARROW or SCROLL select the option.

Press ENTER to confirm.

The ☺ to confirm the parameter edit.

```

FLOW DIRECTION
▶ NORMAL FLOW DIR.
INVERT FLOW DIR.
  
```

**10.4.3.4.2 EN. FLOW MEASURE**

This parameter enables the flow direction measurement and its related totalizer.

Default: BIDIREC (bidirectional)

Range: FORWARD; REVERSE; BIDIREC (bidirectional).

Press ENTER key, the display will be as shown here next.

With UP ARROW or SCROLL select the option.

Press ENTER to confirm.

The ☺ to confirm the parameter edit.

```

FLOW SETUP
FLOW DIRECTION
▶ EN. FLOW MEASURE
MAX FLOW

```

```

EN. FLOW MWASURE
FORWARD
REVERSE
▶ BIDIREC

```

**10.4.3.4.3 MAX FLOW**

Set the flow measurement 100%.

This value adjusts the analog output end scale (20mA) and the frequency output end scale.

The range is related to the sensor DN.

The default value is the maximum flow rate for the MID approval according to the sensor pipe DN.

Press ENTER key, the display will be as shown here next.

With UP ARROW change the digit, with SCROLL moves the cursor.

Press ENTER to confirm.

The ☺ to confirm the parameter edit storage.

```

FLOW SETUP
FLOW DIRECTION
EN. FLOW MEASURE
▶ MAX FLOW

```

```

MAX FLOW

000250.00
m3/h

```

**10.4.4.1 DIGITAL OUTPUT**

The F/P digital output parameters are set in this menu.

Press ENTER to access.

The display will be as shown here next.

Press UP ARROW or SCROLL keys to select the desired function and press ENTER key to access

**10.4.4.1.1 FREQ. MAX**

Sets the maximum frequency in relation to MAX FLOW.

The digital output is active as a frequency output only when the parameter "VOL/PULSE" is set to 0.

Default: 10000Hz;

Range: 00000÷10000 Hz.

Press ENTER key, the display will be as shown here next.

With UP ARROW change the digit, with SCROLL moves the cursor.

Press ENTER to confirm.

The ☺ to confirm the parameter edit storage.

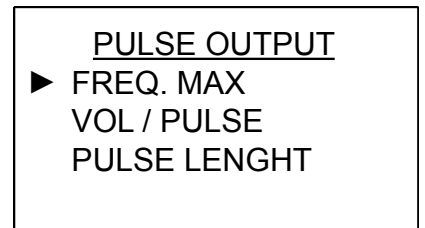
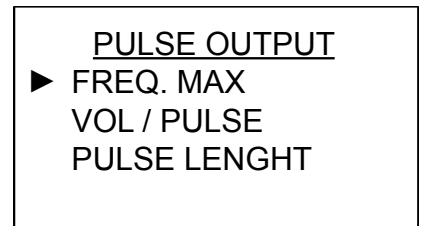
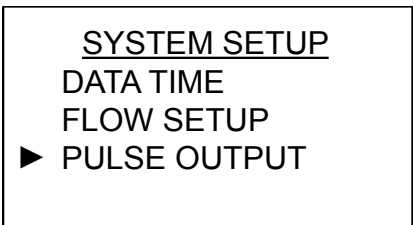

**10.4.4.1.2 VOLUME/PULSE**

Sets the volume per pulse. When this parameter is set to 0, the digital output is active as a frequency output (see "FREQ. MAX").

The measurement unit m<sup>3</sup>.

Default: 0000.00; Range: 0000.00÷9999.99

Press ENTER key, the display will be as shown here next.

With UP ARROW change the digit, with SCROLL moves the cursor.

Press ENTER to confirm.

The ☺ to confirm the parameter edit storage.

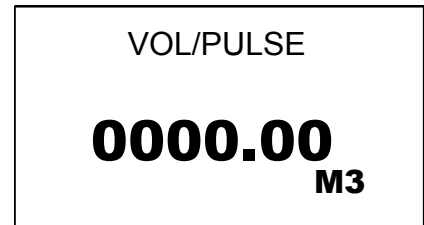
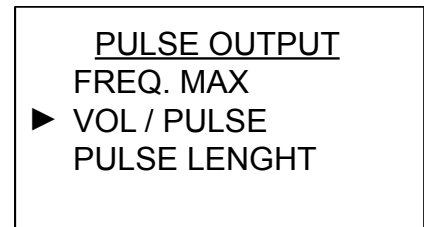
**10.4.4.1.3 PULSE LENGTH**

Sets the pulse width in ms.

Default: 0002ms; Range: 0001÷100ms

Press ENTER key, the display will be as shown here next.

With UP ARROW change the digit, with SCROLL moves the cursor.

Press ENTER to confirm.

The ☺ to confirm the parameter edit storage.

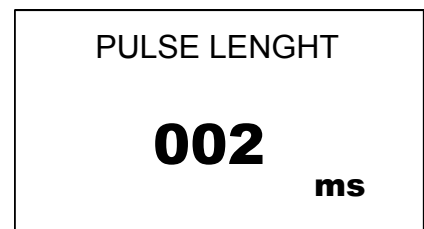
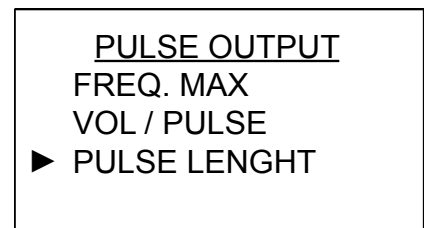
**10.4.4.1.4 PULSE FRONT**

Sets the pulse output energy level. When set ACTIVE LOW the pulse count is low, when set ACTIVE HIGH, the pulse count is high.

Default: ACTIVE LOW; Range: ACTIVE LOW; ACTIVE HIGH.

Press ENTER key, the display will be as shown here next.

With UP ARROW or SCROLL select the option.

Press ENTER to confirm.

The ☺ to confirm the parameter edit storage.

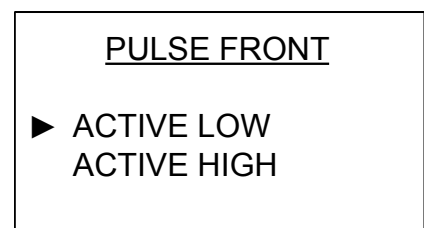
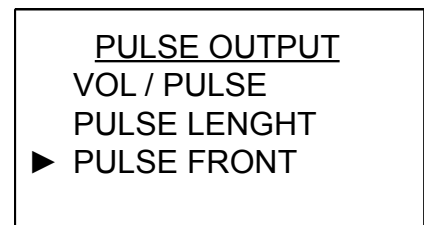



**10.4.4.1.5 DGT OUT COPY RL1**

This function sets the F/P collector output as a copy of RL1.

The available options are:

- NO; the RL1 output is associated with the function set to the parameter “RL1 FUNC” (default setting)
  - YES; the P+/- open collector output is associated with the function set to the parameter “RL1 FUNC”; eg. with “RL1 FUNC” set to “MAX”, the P +/- output state is low (0Vdc) during the non-alarm condition, and is high (24Vdc) during the alarm condition.
- N.B. - Selecting the “YES“ function the F/P output can not be used as an pulse counter or frequency output
- Default: NO; Range: YES; NO

Press ENTER key, the display will be as shown here next.

With UP ARROW or SCROLL select the option.

Press ENTER to confirm.

The ☺ to confirm the parameter edit storage.

```

PULSE OUTPUT
PULSE LENGHT
PULSE FRONT
▶ DGT OUT COPY RL1
  
```

**10.4.4.2 RS485 SETUP**

The configuration parameters of the RS485 port are set in this menu.

Press ENTER to access.

The display will be as shown here next.

Press UP ARROW or SCROLL keys to select the desired function and press ENTER key to access

```

RL1 PULSE COPY
▶ NO
  YES
  
```

```

SYSTEM SETUP
FLOW SETUP
PULSE OUTPUT
▶ RS485 SETUP
  
```

```

RS485 SETUP
▶ NETWORK ID
  BAUD RATE
  PARITY
  
```

**10.4.4.2.1 NETWORK ID**

Set the unity UID in RS485 network.

Default: 001

Range: 001÷247.

Press ENTER key, the display will be as shown here next.

With UP ARROW change the digit, with SCROLL moves the cursor.

Press ENTER to confirm.

The ☺ to confirm the parameter edit storage.

**10.4.4.2.2 BAUD RATE**

Sets the RS485 output Baud Rate.

Default: 9600; Range: 9600; 19200.

Press ENTER key, the display will be as shown here next.

With UP ARROW or SCROLL select the option.

Press ENTER to confirm.

The ☺ to confirm the parameter edit.

**10.4.4.2.3 PARITY**

Sets the RS485 output Parity.

Default: NONE

Range: NONE; ODD; EVEN.

Press ENTER key, the display will be as shown here next.

With UP ARROW or SCROLL select the option.

Press ENTER to confirm.

The ☺ to confirm the parameter edit.

**10.4.4.2.4 STOP BITS**

Sets the RS485 output Stop Bit.

Default: 1 BIT

Range: 1 BIT; 2 BITS.

Press ENTER key, the display will be as shown here next.

With UP ARROW or SCROLL select the option.

Press ENTER to confirm.

The ☺ to confirm the parameter.

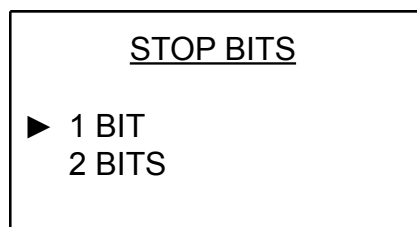
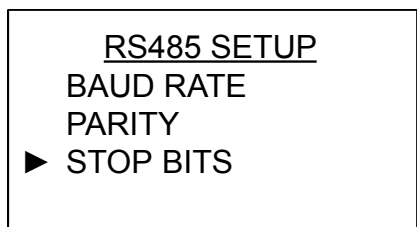
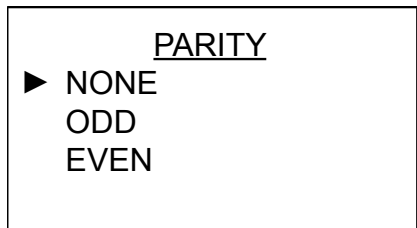
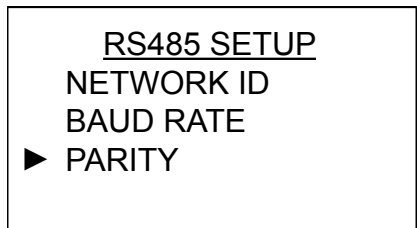
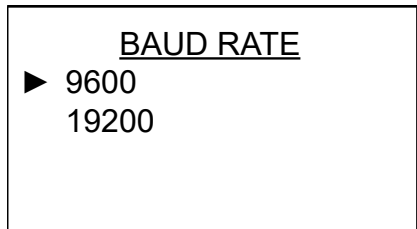
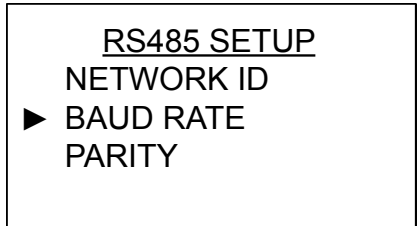
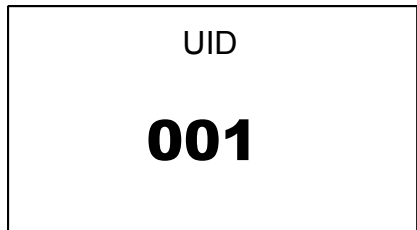
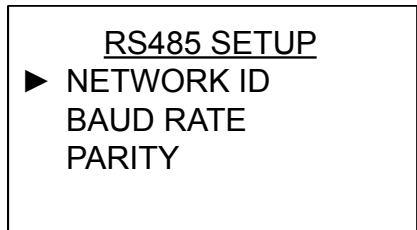

### 10.4.5 TEST menu

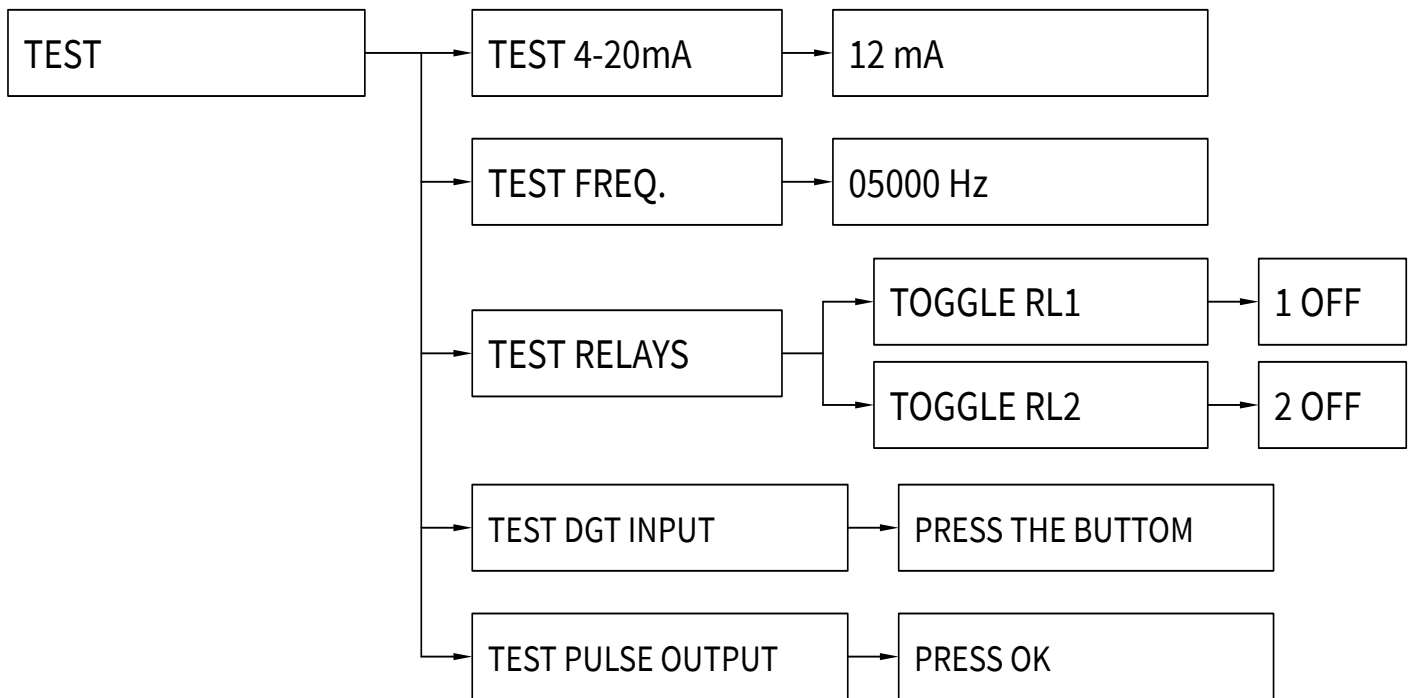

### 10.4.6 OUTPUT SIGNAL TEST (TEST)

Press ENTER key from run mode: the display will be as shown here next, then press SCROLL key to select “SYSTEM SETUP” menu and press ENTER to enter. Press UP ARROW or SCROLL keys to select the desired function and press ENTER key to access.

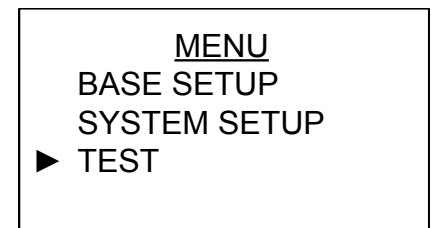

#### 10.4.6.1 TEST 4-20mA

“TEST 4-20mA” force the 4÷20mA signal output to the value set for the test.

Example: Setting the testing value at 16.2 mA, the actual output signal value is forced to 16.2mA. When exiting the TEST function, the 4-20mA output signal returns to be in compliance with the actual measurement.

FLOW set function.

Default: 12mA. Range: 4÷20mA

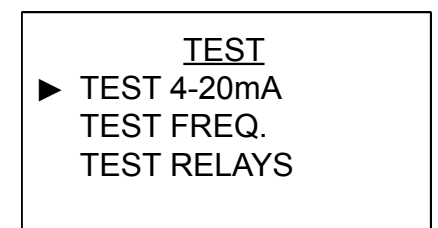

Press ENTER key, the display will be as shown here next.

With UP ARROW change the digit, with SCROLL moves the cursor.

Press ENTER to confirm the test value.

Press LEFT ARROW to exit.

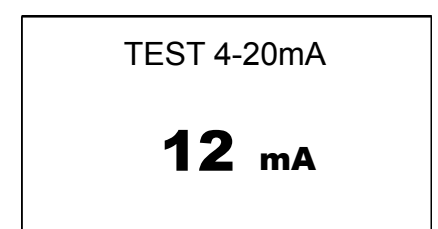

**10.4.6.2 TEST FREQ**

“TEST FREQ” force the frequency signal output to the value set for the test.

Example: Setting the testing value at 2000Hz, the actual output signal value is forced to 2000Hz.

When exiting the TEST function, the frequency output signal returns to be in compliance with the actual measurement.

FLOW set function. Default: 5000 Hz. Range: 0÷10000 Hz

Press ENTER key, the display will be as shown here next.

With UP ARROW change the digit, with SCROLL moves the cursor.

Press ENTER to confirm the test value.

Press LEFT ARROW to exit.

**10.4.6.3 TEST RELAYS**

Test the RL1 and RL2 relay outputs is possible in this menu.

Press ENTER to access.

The display will be as shown here next.

Press UP ARROW or SCROLL keys to select the desired function and press ENTER key to access.

**10.4.6.3.1 TOGGLE RL1/2**

Forcing the status change of the output RL1/2 relay

Press ENTER key, the display will be as shown here next.

Press ENTER to switch from the OFF state to the ON state.

Press LEFT ARROW to exit.

TEST  
TEST 4-20mA  
▶ TEST FREQ.  
TEST RELAYS

TEST FREQ.  
  
**05000**  
Hz

TEST  
TEST 4-20mA  
TEST FREQ.  
▶ TEST RELAYS

TEST RELAYS  
▶ TOGGLE RL1  
TOGGLE RL2

TEST RELAYS  
▶ TOGGLE RL1  
TOGGLE RL2

1 OFF / ON

**10.4.6.4 TEST DGT INPUT**

To verify the “D.I.” digital input funcion.

Not available on this instruments.

**10.4.6.5 TEST PULSE OUTPUT**

To verify the F/P pulse output funcionalidad.

Each time the ENTER key is pressed, the F/P output generates a pulse with a length equal to what set in the “PULSE LENGTH ms” parameter, and simultaneously increments the test counter shown in the display center.

TEST

TEST FREQ.  
TEST RELAYS  
TEST DGT INPUT



PUSH THE BUTTON

TEST

TEST RELAYS  
TEST DGT INPUT  
TEST PULSE OUTPUT

01

PRESS OK

## 10.4.7 Menù. INFO

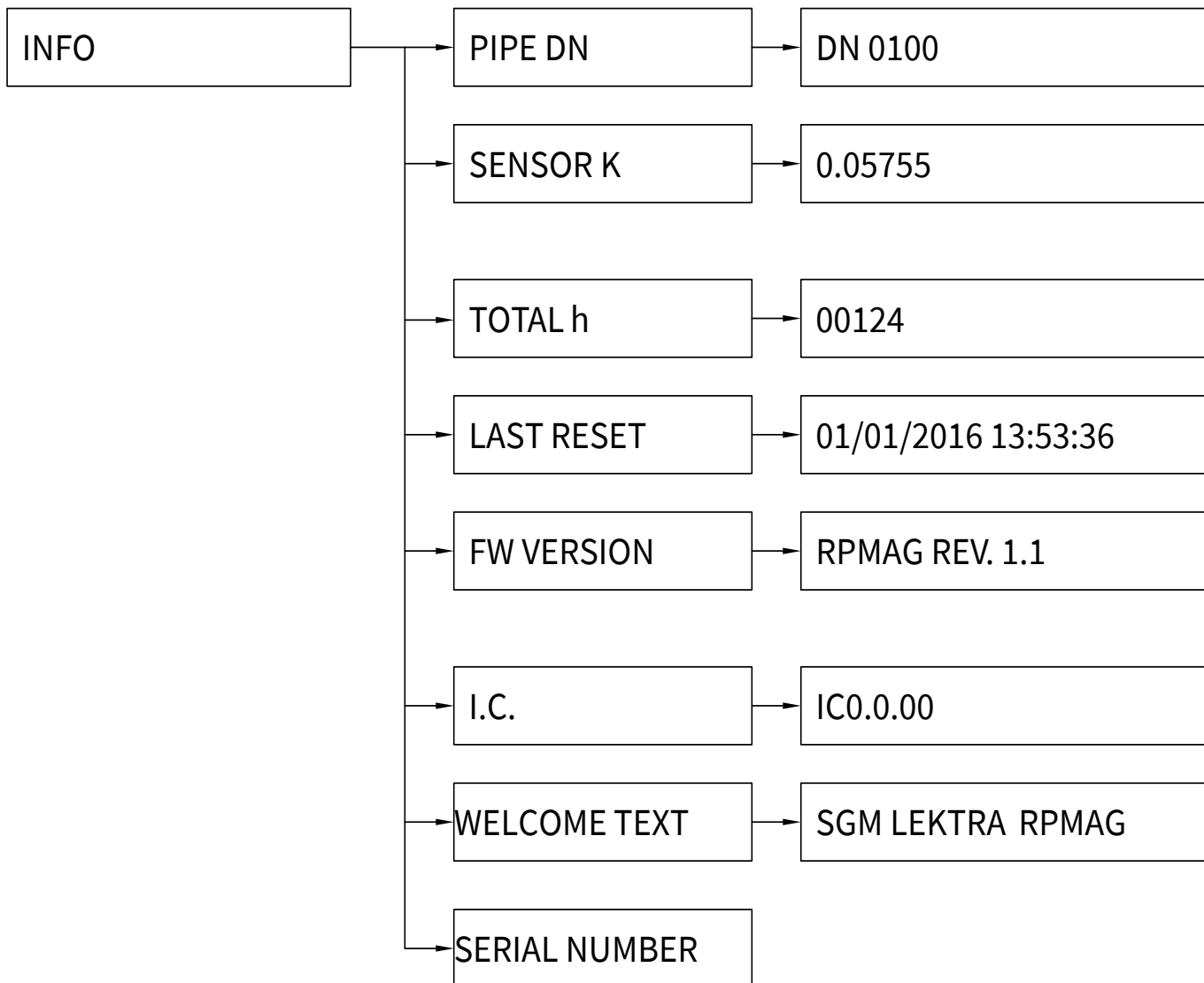

## 10.4.8 SYSTEM INFORMATION (INFO)

Press ENTER key from run mode: the display will be as shown here next, then press SCROLL key to select “INFO” menu and press ENTER to enter.

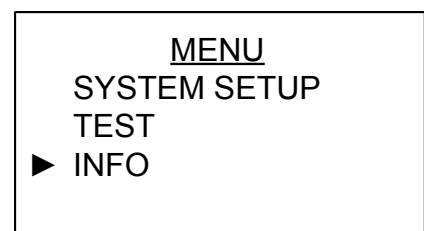

Press UP ARROW or SCROLL keys to select the desired function and press ENTER key to access.

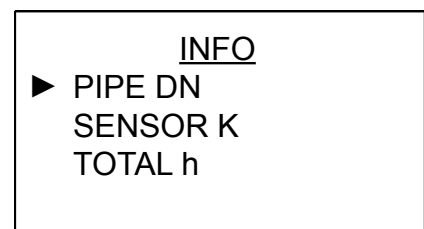

**10.4.8.1 PIPE DN**

Press ENTER to access.

It is useful to check correspondence with the “Connection” data reported on the adhesive rating plate located on the sensor pipe. The display shows the set DN of the measuring pipe.

```

INFO
▶ PIPE DN
  SENSOR K
  TOTAL h
  
```

```

PIPE DN

DN0100
  
```

**10.4.8.2 SENSOR K**

Press ENTER to access.

It is useful to check correspondence with the “SENSOR K” data reported on the adhesive rating plate located on the sensor pipe. The display shows the set SENSOR K of the measuring pipe.

```

INFO
PIPE DN
▶ SENSOR K
  TOTAL h
  
```

```

SENSOR K

0.05755
  
```

**10.4.8.3 TOTAL h**

Press ENTER to access.

The display shows the total hours of the flowmeter operation.

```

INFO
PIPE DN
  SENSOR K
▶ TOTAL h
  
```

```

TOTAL h

00251
  
```

**10.4.8.4 LAST RESET**

Press ENTER to access.

The display shows the date and time of the last reset of the totalizer.

```

INFO
SENSOR K
  TOTAL h
▶ LAST RESET
  
```

```

LAST RESET

01/01/2016 13:53:36
  
```

**10.4.8.5 FW VERSION**

Press ENTER to access.

```

INFO
TOTAL h
LAST RESET
▶ FW VERSION

```

The display shows the firmware version.

```

MAG FLOW

FW Rev. 2.07

```

**10.4.8.6 I.C.**

Press ENTER to access.

```

INFO
LAST RESET
FW VERSION
▶ I.C.

```

The display shows the configuration index (I.C.) of the flowmeter.

```

I.C.

IC1.1.05

```

**10.4.8.7 WELCOME TEXT**

Press ENTER to access.

```

INFO
FW VERSION
I.C.
▶ WELCOME TEXT

```

The display will be as shown here next.

With UP ARROW/SCROLL change the digit, with ENTER moves the cursor.

To confirm press ENTER until the cursor reaches the end of second row and automatically comes back to info menu.

```

WELCOME TEXT

SGM-LEKTRA

MAG FLOW

```



### 10.4.9 CALIBRATION Menu.

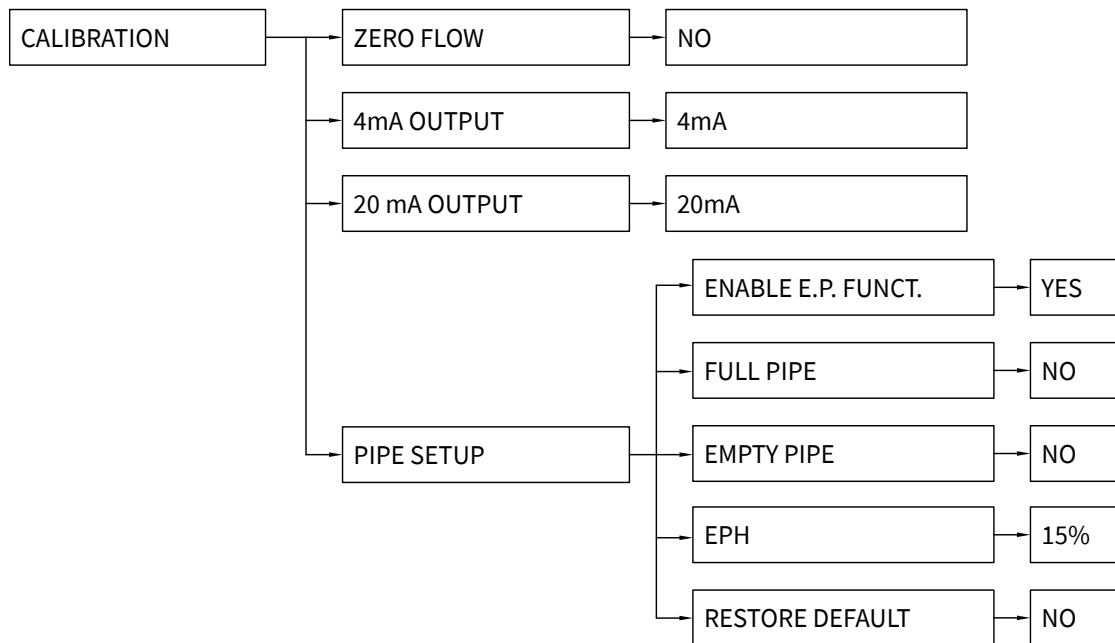

#### 10.4.10 SYSTEM CALIBRATION (CALIBRATION)

**Press** ENTER key from run mode: the display will be as shown here next, then press SCROLL key to select “CALIBRATION” menu and press ENTER key to access.

Press UP ARROW or SCROLL keys to select the desired function and press ENTER key to access.

##### 10.4.10.1 ZERO FLOW

Zero flow measurement calibrate. The sensor must be full and the flow stopped.

Default: NO Range: YES - NO.

Press ENTER key, the display will be as shown here next.

With UP ARROW or SCROLL select the option.

Press ENTER to confirm.

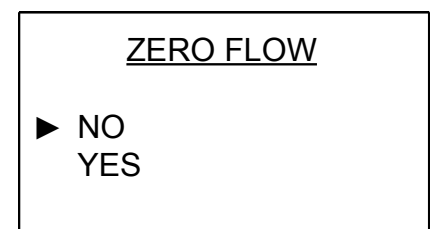
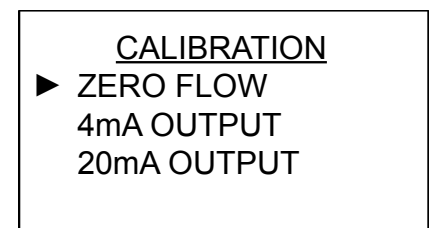
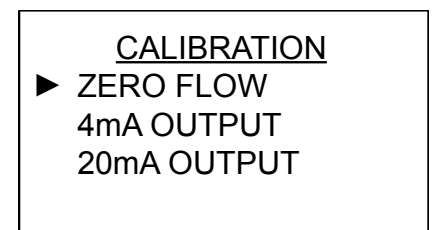
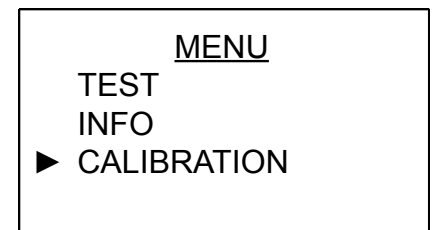

**10.4.10.2 4mA OUTPUT**

Performs calibration of 4mA.

Press ENTER key, the display will be as shown here next.

Connect a mA meter to the analog output; if the detected current measurement is different from 4 mA it is possible to correct the value of the output current with UP ARROW (UP) or SCROLL (DOWN).

Press ENTER (OK) to confirm.

```

CALIBRATION
ZERO FLOW
▶ 4mA OUTPUT
20mA OUTPUT
  
```

```

4mA

UP DOWN OK
  
```

**10.4.10.3 20mA OUTPUT**

Performs calibration of 20mA.

Press ENTER key, the display will be as shown here next.

Connect a mA meter to the analog output; if the detected current measurement is different from 20 mA it is possible to correct the value of the output current with UP ARROW (UP) or SCROLL (DOWN).

Press ENTER (OK) to confirm.

```

CALIBRATION
ZERO FLOW
4mA OUTPUT
▶ 20mA OUTPUT
  
```

```

20mA

UP DOWN OK
  
```

**10.4.10.4 PIPE SETUP**

Performs the calibration of empty pipe sensitivity press.

ENTER to access.

The display will be as shown here next.

press UP arrow or SCROLL keys to select the desired function and press ENTER key to access.

```

CALIBRATION
4mA OUTPUT
20mA OUTPUT
▶ PIPE SETUP
  
```

```

PIPE SETUP
▶ ENABLE E.P. FUNCT.
FULL PIPE
EMPTY PIPE
  
```

**10.4.10.4.1 ENABLE E.P. FUNCT.**

Enables or disables the empty pipe detection.

Default: YES

Range: YES - NO

Press ENTER key, the display will be as shown here next.

With UP arrow or SCROLL select the option.

Press ENTER to confirm.

```

PIPE SETUP
▶ ENABLE E.P. FUNCT.
FULL PIPE
EMPTY PIPE
  
```

```

ENABLE E.P. FUNCT.
▶ NO
YES
  
```

**10.4.10.4.2 FULL PIPE**

ATTENTION: pipe must be full before continue.

Performs a full pipe recognition self calibration.

Default: NO Range: YES - NO.

Press ENTER key, the display will be as shown here next.

With UP ARROW or SCROLL select the option.

Press ENTER to confirm.

The successful calibration is confirmed by the **OK** symbol.

CALIBRATION

4mA OUTPUT

20mA OUTPUT

▶ FULL PIPE

FULL PIPE

▶ NO

YES

CALIBRATION

20mA OUTPUT

FULL PIPE

▶ EMPTY PIPE

**10.4.10.4.3 EMPTY PIPE**

ATTENTION: pipe must be empty before continue.

Performs an empty pipe recognition self calibration.

Default: NO Range: YES - NO.

Press ENTER key, the display will be as shown here next.

With UP ARROW or SCROLL select the option.

Press ENTER to confirm.

The successful calibration is confirmed by the **OK** symbol.

EMPTY PIPE

▶ NO

YES

**10.4.10.4.4 EPH**

Sets the system sensibility level to recognize the air presence in the sensor: the higher the value, the greater the sensitivity.

Default: 15%

Range: 010÷90%.

Press ENTER key, the display will be as shown here next.

With UP ARROW change the digit, with SCROLL moves the cursor.

Press ENTER to confirm.

The ☺ to confirm the parameter edit storage.

PIPE SETUP

EMPTY PIPE

DIG INP E.P.

▶ EPH

EPH

**15%****10.4.10.4.5 RESTORE DEFAULT**

Restores the factory settings of all pipe setup parameters.

Default: NO

Range: NO - YES

Press ENTER key, the display will be as shown here next.

With UP ARROW or SCROLL select the option.

Press ENTER to confirm.

The successful of operation is confirm by the ☺ symbol.

PIPE SETUP

EMPTY PIPE

EPH

▶ RESTORE DEFAULT

RESTORE DEFAULT

▶ NO

YES

### 10.4.11 RELAYS SETUP MENU

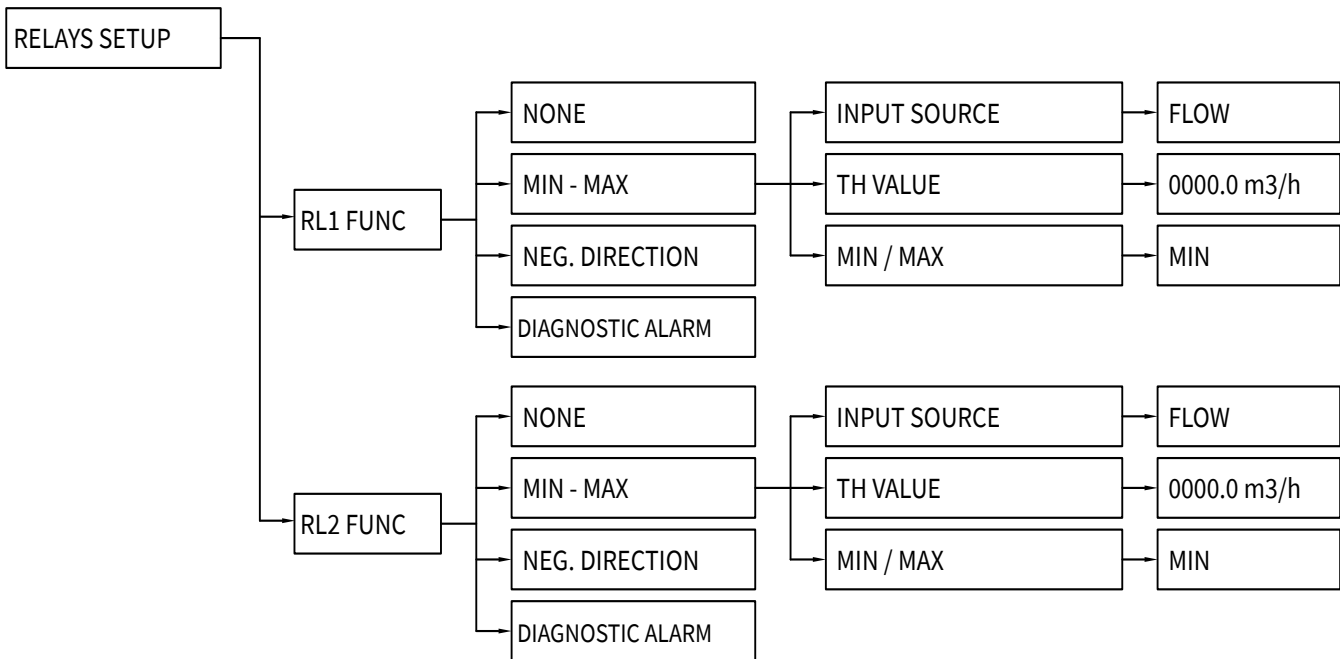

### 10.4.12 RELAY CONFIGURATION (RELAYS SETUP)

Press ENTER key from run mode: the display will be as shown here next, then press SCROLL key to select “RELAYS SETUP” menu and press ENTER to enter.

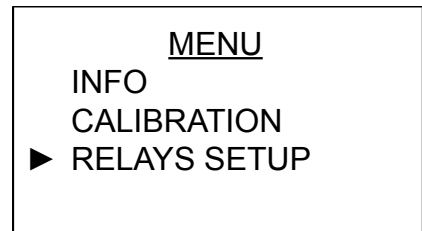

Press UP ARROW or SCROLL keys to select the desired function and press ENTER key to access.

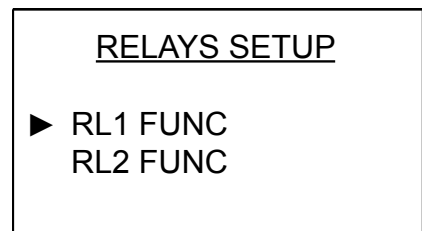

#### 10.4.12.1 RL1/RL2 FUNC

Submenu for output relay RL1/RL2 settings.

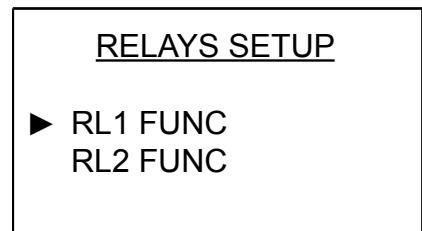

Press UP ARROW or SCROLL keys to select the desired function and press ENTER key to access.

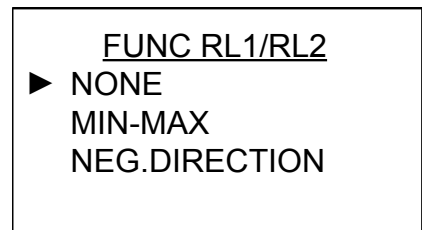

#### 10.4.12.1.1 NONE

**Disable the RL1/RL2 output**

Press ENTER to confirm.

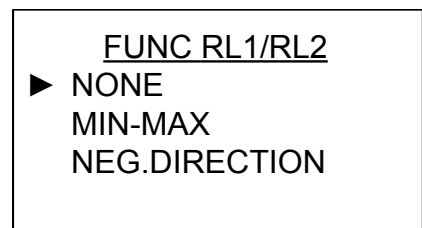

**10.4.12.1.2 MIN-MAX**

Settings for the activation of the RL1/RL2 alarm.

Press UP ARROW or SCROLL keys to select the desired function and press ENTER key to access.

**10.4.12.1.2.1 INPUT SOURCE**

Associates the alarm signal to a measured variable.

Default: FLOW Range: FLOW; ANALOG 1; ANALOG 2;  
ANALOG 1- ANALOG 2

Press ENTER key, the display will be as shown here next.

With UP ARROW or SCROLL select the option.

Press ENTER to confirm.

The ☺ to confirm the parameter edit storage.

**10.4.12.1.2.2 TH VALUE**

Set the alarm threshold.

The associated measurement unit is in relation to the  
“ INPUT SOURCE “ setting.

Press ENTER key, the display will be as shown here next.

With UP ARROW change the digit, with SCROLL moves the cursor.

Press ENTER to confirm.

The ☺ to confirm the parameter edit storage.

**10.4.12.1.2.3 MIN/MAX**

Set the relay operation mode: minimum or maximum alarm  
with relay de-energized and open contact.

Default: MIN Range: MIN – MAX

Press ENTER key, the display will be as shown here next.

With UP ARROW or SCROLL select the option.

Press ENTER to confirm.

The ☺ to confirm the parameter edit storage.

```

RL1/RL2 FUNC
NONE
▶ MIN-MAX
NEG. DIRECTION

```

```

MIN-MAX
▶ INPUT SOURCE
TH VALUE
MIN/MAX

```

```

MIN-MAX
▶ INPUT SOURCE
TH VALUE
MIN/MAX

```

```

INPUT SOURCE
▶ FLOW
ANALOG 1
ANALOG 2

```

```

MIN-MAX
INPUT SOURCE
▶ TH VALUE
MIN/MAX

```

```

TH VALUE
0010.00
m3/h

```

```

MIN-MAX
INPUT SOURCE
TH VALUE
▶ MIN/MAX

```

```

MIN/MAX
▶ MIN
MAX

```

**10.4.12.1.3 NEG. DIRECTION**

Activate the RL1/RL2 output as a reverse instantaneous negative flow rate alarm.  
Press ENTER to confirm.

```
RL1 FUNC
NONE
MIN-MAX
▶ NEG. DIRECTION
```

**10.4.12.1.4 DIAGNOSTIC ALARM**

Activate the RL1/RL2 output for diagnostic alarm:  
coil connection interruption connection; empty pipe.  
Press ENTER to confirm.

```
RL1 FUNC
MIN-MAX
NEG. DIRECTION
▶ DIAGNOSTIC ALARM
```



# 12-FACTORY TEST AND QUALITY CERTIFICATE



I certify that the equipment:

(Electromagnetic induction flow measurement)

conforms to the technical requirements stated on Technical Data Shee and it is made in compliance with the assembly and checking procedures

Quality Control Manager: ..... Production and check date: .....

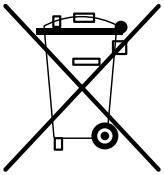

This mark on the instrument indicates that the product and its electronic accessories must not be disposed of with other household waste at the end of their useful life.

To avoid possible damage to the environment or human health resulting from uncontrolled waste disposal, please return the equipment directly to a specialized recycling company, in compliance with local regulations.



**NI - MH**

This instrument is powered by a battery type 2,4V triple-A, 0.6Ah NiMH; at the end of the life of the battery or the instrument, do not disperse it in the environment.

The battery must be disposed of in the appropriate collection centers.